

FLYGT

Installation, Care and Maintenance

3153



CONTENTS

Safety _____	2	Electrical connections _____	10
Data plate interpretation _____	3	Connection of stator and motor leads _____	11
Guarantee _____	4	Sensor connections _____	16
Product description _____	4	Operation _____	18
Introduction _____	4	Before starting _____	18
Application _____	4	Care and Maintenance _____	19
Motordata _____	5	Service/Inspection _____	19
Design of the pump _____	6	Changing the coolant _____	21
Transportation and storage _____	8	Removing the impeller _____	22
Installation _____	8	Installing the impeller _____	23
Handling equipment _____	8	Fault tracing _____	24
Safety precautions _____	9	Service log _____	27
Installation alternatives _____	10		

SAFETY

This manual contains basic information on the installation, operating and maintenance and should be followed carefully. It is essential that these instructions are carefully read before installation or commissioning by both the installation crew as well as those responsible for operation or maintenance. The operating instructions should always be readily available at the location of the unit.

Identification of safety and warning symbols



General Danger:

Non-observance given to safety instructions in this manual, which could cause danger to life have been specifically highlighted with this general danger symbol.



High Voltage:

The presence of a dangerous voltage is identified with this safety symbol.

WARNING!

Non-observance to this warning could damage the unit or affect its function

Qualifications of personnel

An authorized (certified) electrician and mechanic shall carry out all work.

Safety regulations for the owner/operator

All government regulations, local health and safety codes shall be complied with.

All dangers due to electricity must be avoided (for details consult the regulations of your local electricity supply company).

Unilateral modification and spare parts manufacturing

Modifications or changes to the unit/installation should only be carried out after consulting with ITT Flygt.

Original spare parts and accessories authorized by the manufacturer are essential for compliance. The use of other parts can invalidate any claims for warranty or compensation.

Dismantling and re-assembly

If the pump has been used to pump hazardous media, care must be taken that, when draining the leakage, personnel and environment are not endangered.

All waste and emissions such as used coolant must be appropriately disposed of. Coolant spills must be cleaned up and emissions to the environment must be reported.

The pumping station must be kept tidy and in good order at all times.

All government regulations shall be observed.

The pictures in this manual may differ somewhat from the delivered pump depending on the hydraulic end configuration.

DATA PLATE INTERPRETATION

General data plate

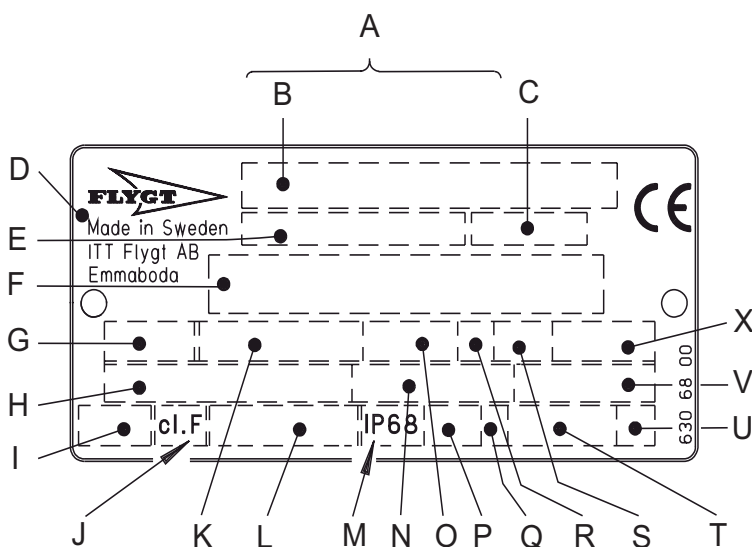

- A Serial number
- B Product code + Number
- C Curve code / Propeller code
- D Country of origin
- E Product number
- F Additional information
- G Phase; Type of current; Frequency
- H Rated voltage
- I Thermal protection
- J Thermal class
- K Rated shaft power
- L International standard
- M Degree of protection
- N Rated current
- O Rated speed
- P Max. submergence
- Q Direction of rotation: L=left, R=right
- R Duty class
- S Duty factor
- T Product weight
- U Locked rotor code letter
- V Power factor
- X Max. ambient temperature

Approval plates

These approval plates apply to an explosion-proof submersible Flygt pump. The plates are used together with the general data plate on the pump.

EN: European Norm

ATEX Directive

EN 50014, EN 50018, EN 1127-1

⊕ II 2 G EEx dII B T3 for ambient temperatures $\leq 40^{\circ}\text{C}$
 EEx dII B T4 for ambient temperatures $\leq 25^{\circ}\text{C}$

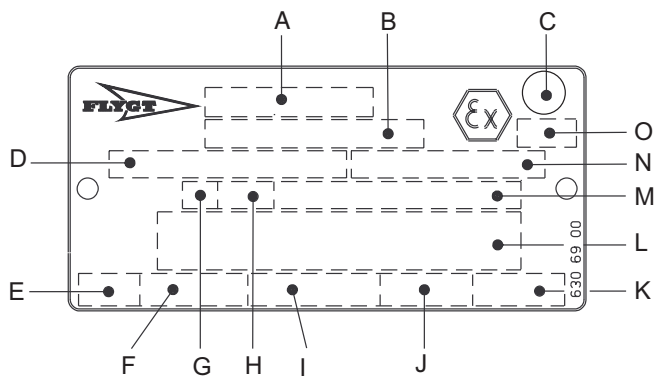

- A Approval
- B Approval authority + Approval Number
- C Approval for Class I
- D Approved drive unit
- E Stall time
- F Starting current / Rated current
- G Duty class
- H Duty factor
- I Input power
- J Rated speed
- K Controller
- L Additional information
- M Max. ambient temperature
- N Serial number
- O ATEX marking

FM: Factory Mutual

Class I Div. I Grp C and D

Class II and III Div. I Grp E, F and G

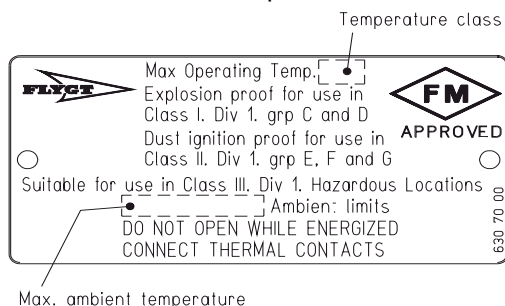

GUARANTEE

Flygt undertakes to remedy faults in products sold by Flygt provided:

- that the fault is due to defects in design, materials or workmanship;
- that the faults are reported to Flygt or Flygt's representative during the guarantee period;
- that the product is used only under condition described in the Installation, Care and Maintenance manual and in applications for which it is intended;
- that the monitoring equipment incorporated in the product is correctly **connected** and **in use**;

— that all service and repair work is done by a work shop authorized by Flygt;

— that genuine Flygt parts are used.

Hence, the guarantee does not cover faults caused by deficient maintenance, improper installation, incorrectly executed repair work or normal wear and tear.

Flygt assumes no liability for either bodily injuries, material damages or economic losses beyond what is stated above.

Flygt guarantees that spare parts will be kept for 15 years after that the manufacture of this product has been discontinued.

PRODUCT DESCRIPTION

Introduction

Thank you for buying a submersible Flygt pump. In this Installation, Care and Maintenance manual you will find general information on how to install and service the 3153 pump to give it a long and reliable life.

Application

This Installation, Care and Maintenance manual applies to a submersible Flygt pump.

If you have bought an Ex-approved pump (please see approval plate on your pump or Parts List) special handling instructions apply as described in this document.

The pump is intended to be used for;

- pumping of waste water
- pumping of raw or clean water
- pumping of sludge

Installation alternatives

P = semi permanent wet well arrangement with pump installed by means of twin guide bars with automatic connection to discharge.

S = transportable version with hose connection or flange for connection to discharge pipeline.

T = permanent dry well or in-line arrangement with flange connection to suction and discharge pipework; vertical mounting.

Z = Permanent dry well or in-line arrangement with flange connection to suction and discharge pipework; horizontal mounting.

In **T**, **Z** and **S** installations the pump must be equipped with cooling jacket.

For further information on applications, contact your nearest Flygt representative.

Pump versions

LT = low head execution

MT = medium head execution

HT = high head execution

Liquid temperature: max. 40°C (104°F)

also available in an execution for liquid temperature up to 70°C (158°F) only with cooling jacket.

Higher temperatures than 40° C (104° F) are not permitted for the Ex-approved pumps.

Liquid density: max. 1100 kg/m³ (9.2 lb per US gal.)

The pH of the pumped liquid: 5.5—14.

Lowest liquid level: See illustration on page 6.

Depth of immersion: max. 20 m (65 ft).

Weights

Weight including connections, but without motor cable in kg (lb).

Pump type	With cooling jacket	Without cooling jacket	Discharge connection
NP 3153 LT	239 (528)	226 (499)	78 (172)
NP 3153 LT 6-pole	298 (657)	285 (628)	98 (217)
NP3153 MT	203 (448)	190 (419)	54 (119)
NP 3153 HT	189 (417)	176 (388)	42 (93)
NS 3153 LT	257 (567)	—	
NS 3153 LT 6-pole	361 (796)	—	
NS 3153 MT	232 (511)	—	
NS 3153 HT	209 (461)	—	
NT 3153 LT	326 (719)	—	
NT 3153 LT 6-pole	417 (919)	—	
NT 3153 MT	272 (600)	—	
NT 3153 HT	235 (518)	—	
NZ 3153 LT	327 (721)	—	
NZ 3153 LT 6-pole	386 (853)	—	
NZ 3153 MT	256 (566)	—	
NZ 3153 HT	232 (511)	—	

Motordata

50 Hz, 7.5 kW, 1460 r/min, 3~, 4-pole

Voltage V	Rated current A	Starting current A
230VD	29	168
380VD	17	96
380VY	17	102
400VD	16	91
400VY	17	98
415VD	15	86
500VD	13	70

60 Hz, 12 hp, (8.9 kW) 1760 r/min, 3~, 4-pole

Voltage V	Rated current A	Starting current A
230Y//	32	204
460VD	16	95
575VD	12	73
600VD	12	78

50 Hz, 9.0kW, 1460 r/min, 3~, 4-pole

Voltage V	Rated current A	Starting current A
230VD	32	181
380VD	20	114
380VY	19	110
400VD	19	107
400VY	19	105
415VD	18	105
500VD	15	86

60 Hz, 15 hp, (11.2 kW) 1760 r/min, 3~, 4-pole

Voltage V	Rated current A	Starting current A
230Y//	39	228
460VD	19	112
575VD	15	90
600VD	15	95

50 Hz, 11.0kW, 1465 r/min, 3~, 4-pole

Voltage V	Rated current A	Starting current A
230VD	40	244
380VD	25	148
380VY	25	152
400VD	24	146
400VY	23	141
415VD	23	141
500VD	19	111

60 Hz, 18 hp, (13.4 kW) 1760 r/min, 3~, 4-pole

Voltage V	Rated current A	Starting current A
230Y//	47	296
460VD	24	153
575VD	19	116
600VD	19	123

50 Hz, 9.0kW, 955 r/min, 3~, 6-pole

Voltage V	Rated current A	Starting current A
230VD	36	151
380VD	22	95
380VY	22	90
400VD	21	90
400VY	21	88
415VD	20	81
440VD	20	87
500VD	17	73

60 Hz, 15 hp, (11.2 kW) 1150 r/min, 3~, 6-pole

Voltage V	Rated current A	Starting current A
230Y//	46	212
460VD	21	95
575VD	17	76
600VD	17	81

DESIGN OF THE PUMP

Motor

Squirrel-cage 3-phase induction motor for 50 Hz or 60 Hz.

The motor is started by means of direct on-line or star delta start.

The motor can be run continuously or intermittently with a maximum of 15 evenly spaced starts per hour.

Flygt motors are tested in accordance with IEC 34-1.

The stator is insulated in accordance with class H (180°C, 360 F). The motor is designed to supply its rated output at $\pm 5\%$ variation of the rated voltage. Without overheating the motor, $\pm 10\%$ variation of the rated voltage can be accepted provided that the motor does not run continuously at full load. The motor is designed to operate with a voltage imbalance of up to 2 % between the phases.

Bearings

The support bearing of the shaft is a single row ball bearing. The main bearing of the shaft is a double row angular contact ball bearing.

Mechanical seal unit

The pump has one shaft mechanical seal unit consisting of two independently operating seals:

- | | | |
|---------|-------------|--|
| Alt I | Inner seal: | Aluminum Oxide/Carbon
Al_2O_3/CSb |
| | Outer seal: | Corrosion resistant cemented
carbide WCCR/WCCR |
| Alt II | Inner seal: | Corrosion resistant cemented
carbide WCCR/WCCR |
| | Outer seal: | Corrosion resistant cemented
carbide WCCR/WCCR |
| Alt III | Inner seal: | Aluminum Oxide/Corrosion
resistant cemented carbide
$Al_2O_3/WCCR$ |
| | Outer seal: | Silicon Carbide RSiC/RSiC |

Monitoring equipment

The stator incorporates three thermal contacts connected in series that activate an alarm at overtemperature.

The thermal contacts: open at 140°C (285°F). The sensors shall be connected to Flygt's monitoring unit MiniCAS II or equivalent unit.

The monitoring equipment shall be of a design that makes automatic restart impossible.

The 3153 is supplied with inspection sensor FLS10 for sensing the presence of any liquid in the inspection chamber.

Cooling (without cooling jacket)

The pump is cooled by the ambient liquid. For lowest liquid level, see illustration below*).

Without cooling jacket

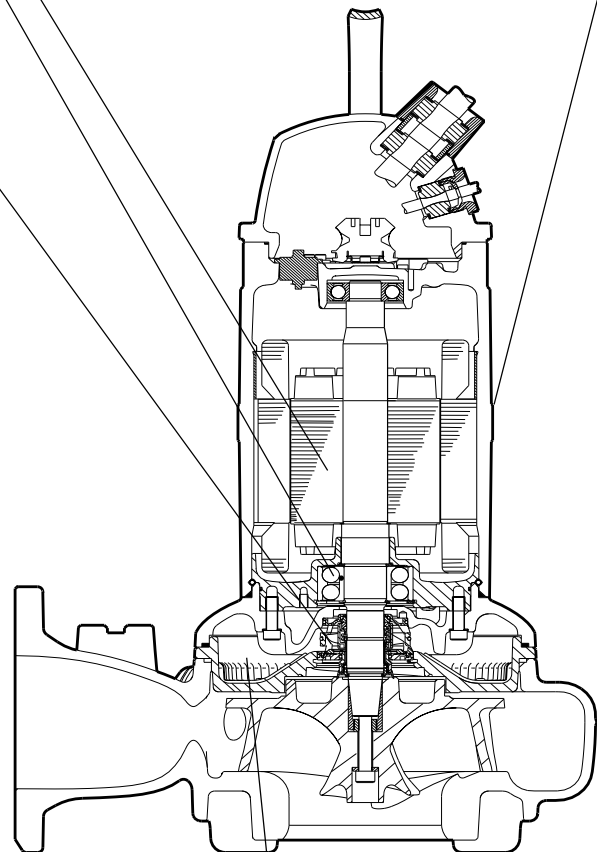

30720

Seal housing

A coolant fluid lubricates and cools the mechanical seal unit and acts as a buffer between the pumped media and the electric motor.

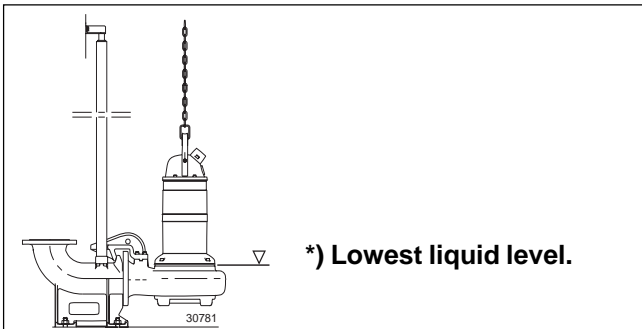

*) Lowest liquid level.

30781

With cooling jacket

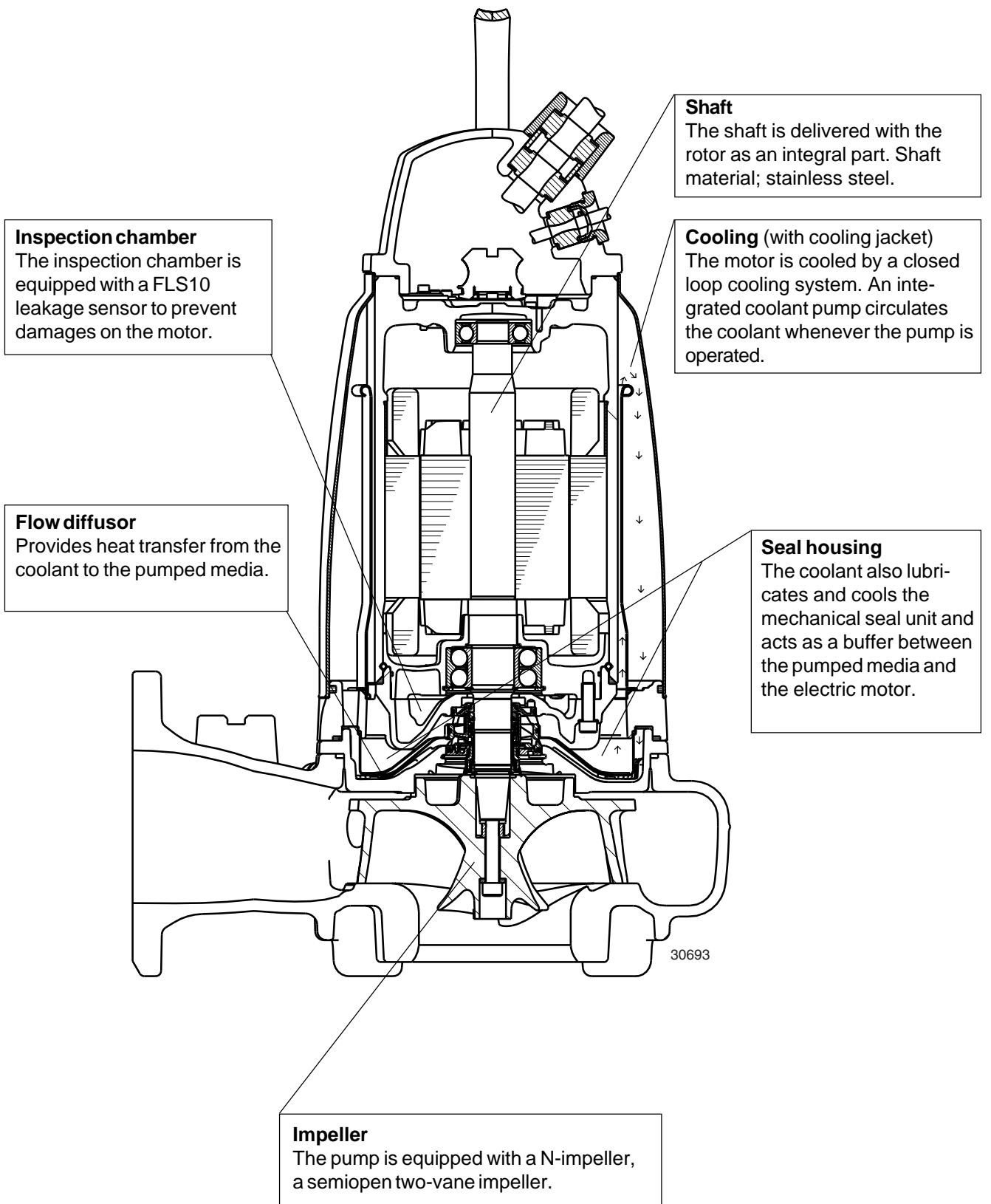

TRANSPORTATION AND STORAGE

The pump may be transported and stored in a vertical or horizontal position. Make sure that the pump cannot roll or fall over.

WARNING!

Always lift the pump by its lifting handle never by the motor cable or the hose.

The pump is frostproof as long as it is operating or is immersed. If the pump is hoisted from the sump when the temperature is below the freezing point, the impeller and shaft seal may freeze.

A frozen impeller and shaft seal can be thawed by allowing the pump to stand immersed in the liquid for a short period before it is started. Never use a naked

flame to thaw the pump. The pump shall be run for a short period after being taken up in order to expel all remaining water.

For longer periods of storage, the pump must be protected against moisture and heat. The impeller should be rotated by hand occasionally (for example every other month) to prevent the seal rings from sticking together. If the pump is stored for more than 6 months, this rotation is mandatory.

After a long period of storage, the pump should be inspected before it is put into operation. Pay special attention to the shaft seal and the cable entry.

Follow the instructions under the heading "Before starting".

INSTALLATION

Handling equipment

Always pay extra attention to safety aspects when working with lifting equipment.

Lifting equipment is required for handling the pump. The lifting chain and the shackle should be in stainless steel and inspected every year.



- **Stay clear of suspended loads.**
- **Always lift the pump by its lifting handle – never by the motor cable or the hose.**

The minimum height between the lifting hook and the floor shall be sufficient to lift the pump out of the sump.

The lifting equipment shall be able to hoist the pump straight up and down in the sump, preferably without the need for resetting the lifting hook.

Oversized lifting equipment could cause damage if the pump should stick when being lifted.

Make sure that the lifting equipment is securely anchored and in good condition.

Check that the lifting handle and chain are in good condition.

To ensure proper installation, please see the dimensions on the dimensional drawing.

WARNING! The end of the cable must not be submerged. It must be above flood level, as water may penetrate through the cable into the junction box or the motor.

For automatic operation of the pump (level control), it is recommended that the level regulators should be used at low voltage. The data sheet delivered with the regulators gives the permissible voltage. Local rules may specify otherwise.

Clean out all debris from the sump before the pump is lowered down and the station is started.



Special rules apply to installation in explosive atmosphere;

- **Intrinsically safe circuits are normally required (Ex i) for the automatic level control system by level regulators.**
- **Minimum stop level should be according to the dimensional drawing.**
- **The pump must never run dry.**

Safety precautions

In order to minimize the risk of accidents in connection with service and installation work, the following rules should be followed:

1. Never work alone. Use a lifting harness, safety line and a respirator as required. Do not ignore the risk of drowning.
2. Make sure there are no poisonous gases within the work area.
3. Check the explosion risk before welding or using electric hand tools.
4. Before the pump is installed check that the cable and cable entry have not been damaged during the transportation.
5. Observe strict cleanliness. Do not ignore health hazards.
6. Bear in mind the risk of electrical accidents.
7. Make sure that the lifting equipment is in good condition and comply to local ordinances.
8. Provide a suitable barrier around the work area, e.g. a guard rail.
9. Make sure you have a clear path of retreat!
10. Use safety helmet, safety goggles and protective shoes.
11. All personnel who work with sewage systems must be vaccinated against diseases to which they may be exposed.
12. A first-aid kit must be close at hand.
13. Note that special rules apply to installation in explosive atmosphere.

Follow all other health and safety rules and local codes and ordinances.

Installation alternatives

P- installation

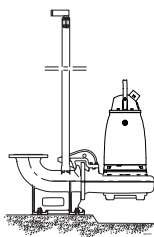

In the P installation, the pump is installed on a stationary discharge connection and operates completely or partially submerged in the pumped liquid.

In addition to the pump the following items are required:

Guide bars consisting of two hot dip galvanized or stainless steel pipes.

Guide bar bracket for attaching the guide bars to the access frame or the upper part of the sump.

Level regulators or other control equipment for start, stop and alarm.

Cable holder for holding the cable and regulating the height of the level regulators.

Access frame (with covers) to which the upper guide bar bracket and cable holder can be attached.

Discharge connection for connecting the pump to the discharge line. The discharge connection has a flange which fits the pump casing flange and a bracket for attaching the guide equipment.

Bushings for vibration damping between the guide bars and the discharge connection.

Instructions

Provide a barrier around the pump pit, for example a guardrail.

Arrange for a cable between the sump and the electric control box. Make sure that the cables are not sharply bent or pinched.

Place the access frame in position.

Align the frame so that it is horizontal and then grout it in place.

Grout the anchor bolts in place. Be careful when aligning and positioning the discharge connection in relation to the access frame.

Place the discharge connection in position and tighten the nuts.

Secure the guide bars in the bracket.

Check that the guide bars are placed vertically by using a level or a plumb line.

Connect the discharge pipe to the discharge connection.

Bolt the cable holder to the access frame. Thread the level regulator cables through the holes in the cable holder and adjust the height of the level regulators.

Protect bolts and nuts with corrosion preventive compound.

Lower the pump along the guide bars.

Fasten the lifting chain (stainless steel) on the access frame and the cables on the cable holder. Make sure that the cables cannot be sucked into the inlet of the pump. Support straps are required for deep installations.

Run the cables up to the electric control box.

Clean out debris from the sump before starting up the station.

The pump can be hoisted up along the guide bars for inspection without any connections having to be undone.

S- installation

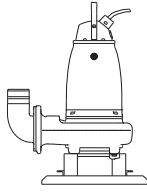

In the S- installation, the pump is transportable and intended to operate completely or partially submerged in the pumped liquid. The pump is equipped with a connection for hose or pipe, see "Parts list".

The pump stands on a base stand.

WARNING! Watch for the starting jerk which can be powerful.

T/Z- installation

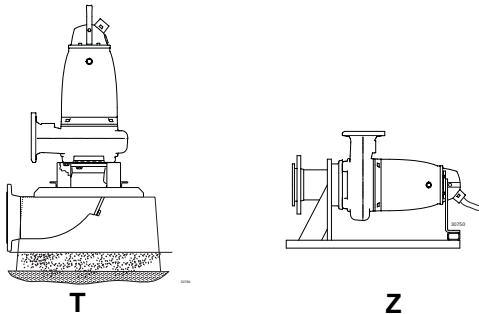

In the T- installation, the pump is installed in a stationary position in a dry well next to the wet sump.

In the Z- installation the pump is installed in a horizontal position on a support stand and a bell-mouth is connected to the inlet pipe.

The pump has a watertight motor and will therefore not be damaged in the event of flooding.

The pump is equipped with a cooling jacket.

In addition to the pump the following items are required:

Support stand for anchoring the pump to a base.

Shut-off valves to permit the pump to be removed for service.

Level regulators or other control equipment for start, stop and alarm.

WARNING! The risk of freezing is particularly great at certain T or Z installations.

Instruction

Bolt the base stand to the concrete base by means of the anchor bolts. Bolt the pump to the base stand and the suction connection.

Check that the pump is vertical.

Connect the motor cable, suction line and discharge line.

Make sure that the weight of the pump does not bear on the system piping.

ELECTRICAL CONNECTIONS



- Before starting work on the pump, make sure that the pump and the control panel are isolated from the power supply and cannot be energized.
- If the pump is equipped with automatic level control, there is a risk of sudden restart.
- If persons are likely to come into physical contact with the pump or pumped media (liquid), e.g. on construction sites and farms, the earthed (grounded) socket must have an additional earth-(ground)-fault protection device (GFI) connected.

All electrical work shall be carried out under the supervision of an authorized electrician. Local codes and regulations shall be complied with.



All electrical equipment must be earthed (grounded). This applies to both pump equipment and any monitoring equipment. Failure to heed this warning may cause a lethal accident. Make sure that the earth (ground) lead is correctly connected by testing it.



NOTE for Ex version

- Electrical connections on the explosion-proof motor must be made by authorized personnel.

Flygt disclaims all responsibility for work done by untrained, unauthorized personnel.

- The pump may be used only in accordance with the approved motor data stated on the pump's plates.
- Thermal contacts must be connected to protection circuit intended for that purpose according to the approval of the product.

Check the data plate to determine which voltage supply is valid for your pump.

Check that the main voltage and frequency agree with the specifications on the pump data plate.

If the pump can be connected to different voltages, the connected voltage is specified by a yellow sticker.

Connect the motor cable to the starter equipment as illustrated in the wiring diagrams.

Leads that are not in use must be isolated.

The cable should be replaced if the outer sheath is damaged. Contact a Flygt service shop. Make sure that the cable does not have any sharp bends and is not pinched.

Under no circumstances may the starter equipment be installed in the sump.

WARNING! For safety reasons, the earth (ground) lead should be approx. 100 mm (4.0") longer than the phase lead. If the motor cable is jerked loose by mistake, the earth (ground) lead should be the last lead to come loose from its terminal. This applies to both ends of the cable.

The motor is convertible between different voltages as stated on the data plate. This conversion is done on the terminal board or the contactor.



Bear in mind the risk of electrical shock and the risk of explosion if the electrical connections are not correctly carried out.

When using a variable-frequency-drive (VFD) the shielded cable (type NSSHÖU.../3E+St) should be used. Contact your Flygt representative and ask your VFD-supplier for electrical limitations. Also please see VFD-recommendation Flygt article no. 893472.

Connection of stator and motor leads

Check on the data plate which connection, Y, D or YD, is valid for the voltage supply. Then, depending on voltage, arrange the connection on the terminal board in accordance with Y, D or YD. See figure.

Connect the motor cable to the connection block, U1, V1, W1 and earth (ground). Connect the leads from the motor control circuit.

If star-delta start is used, motor cables are connected as shown in the figure. Links (jumper strips) are not used with star-delta start.

Make sure that the pump is correctly earthed (grounded).

Install the o-ring (33) and connection cover (32).

Tighten the screws and the gland nut so that the cable entry unit bottoms out.

Connect the motor cable to the starter equipment. Check the direction of rotation, see "Before starting".

If the direction of rotation is wrong, transpose two of the phase leads.

Remember that the starting surge with the direct-on line start can be up to six times higher than the rated current. Make sure that the fuses and circuit breakers are of the proper amperage.

The incorporated thermal contacts must be connected and in use. The pump must be connected to an over-load protection which must be set to rated power.

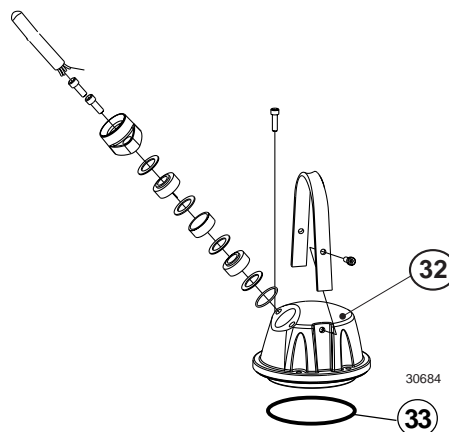

SUBCAB 4G/SUBCAB AWG*

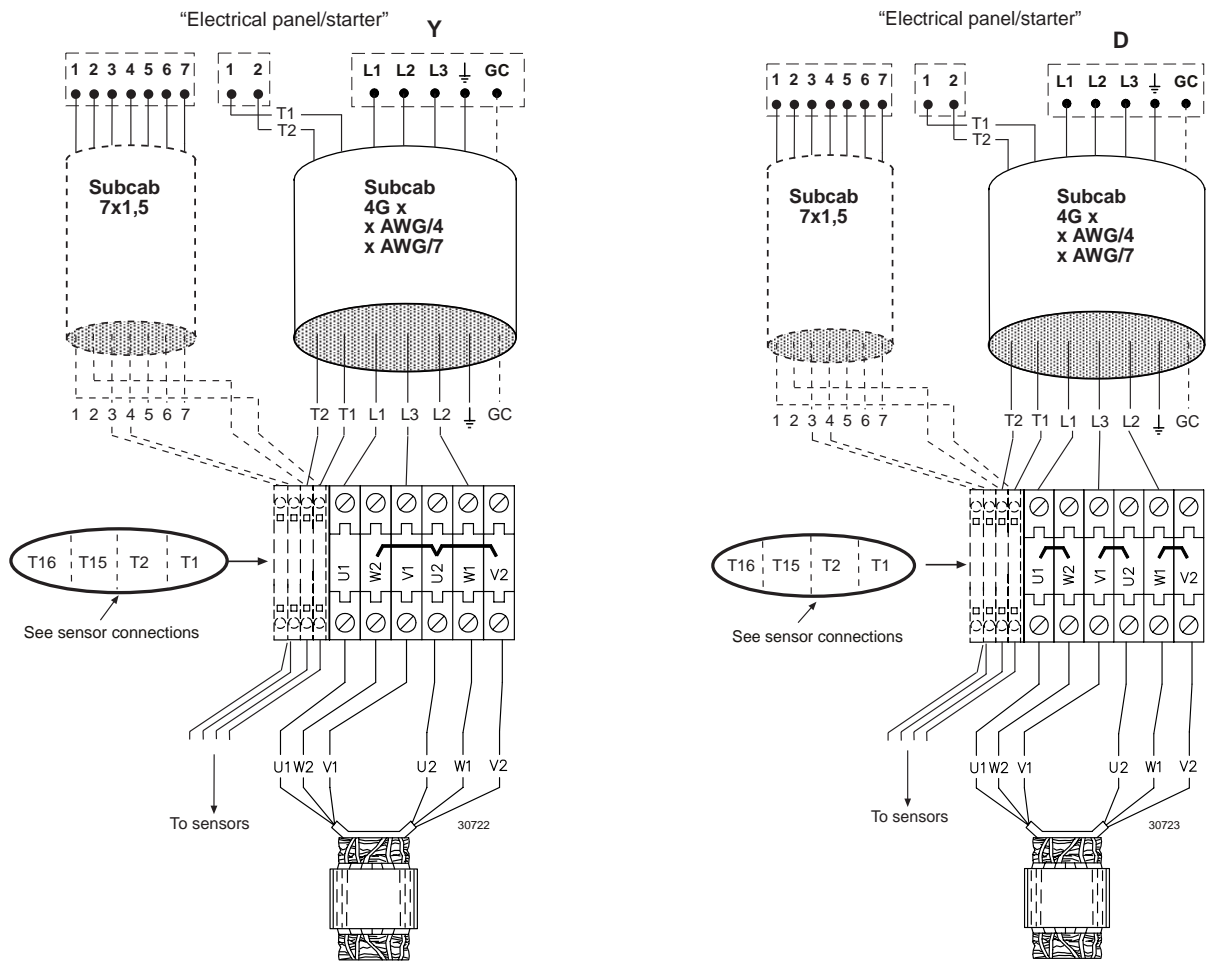

*** SUBCAB AWG**

Mains	Lead	Pump terminal board	Stator leads connection:	Pump terminal board
			Stator lead	
L1	Brown/(Red*)	U1	U1, red	U1
L2	Blue (White*)	W1	W2, black	W2
L3	Black (Black*)	V1	V1, brown	V1
Earth (Ground)	Yellow/Green	⊥	U2, green	U2
Groundcheck (GC)	Yellow		W1, yellow	W1
			V2, blue	V2
Control	Cable lead			
T1	T1/orange*			
T2	T2/blue*			

SUBCAB7G

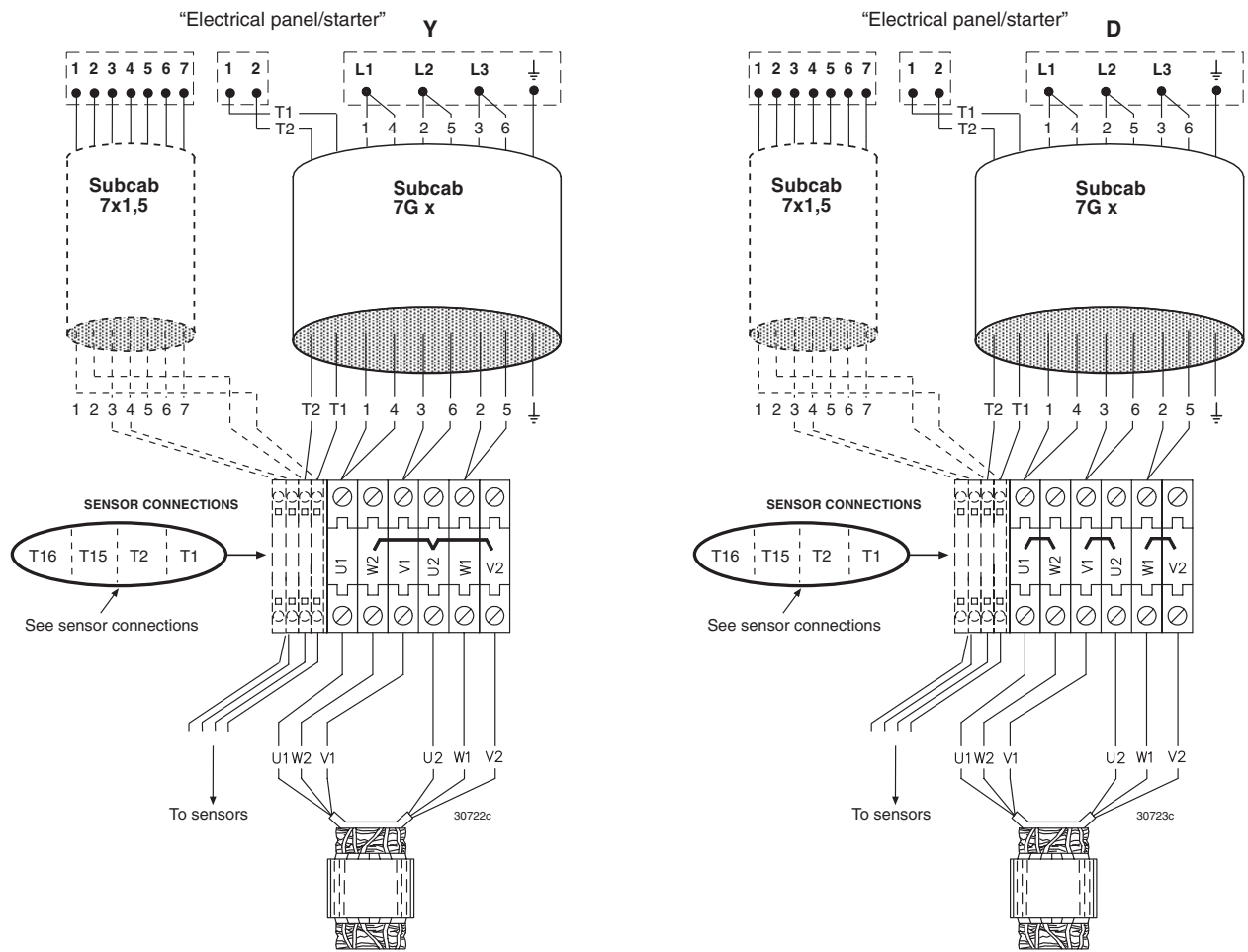

SUBCAB

Mains	Lead	Pump terminal board	Stator lead	Pump terminal board
L1	1 black	U1	U1, red	U1
L2	2 black	W1	W2, black	W2
L3	3 black	V1	V1, brown	V1
L1	4 black	U1	U2, green	U2
L2	5 black	W1	W1, yellow	W1
L3	6 black	V1	V2, blue	V2
Earth (Ground)	Yellow/Green	⊥		
Control	Cable lead			
T1	T1/black*			
T2	T2/black*			

SUBCAB7G

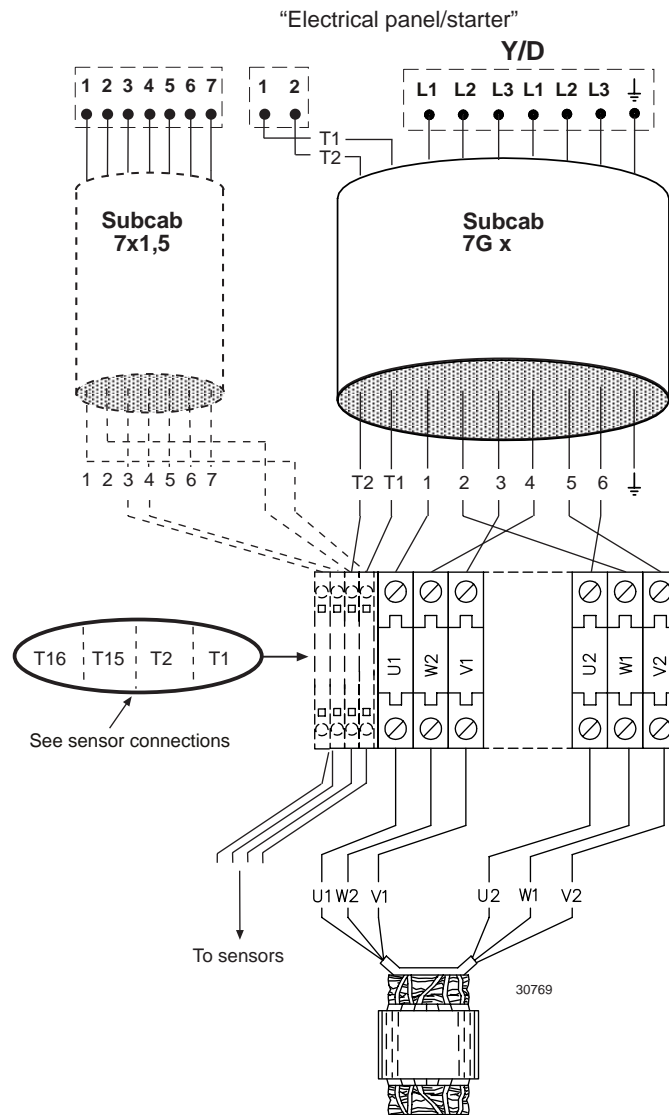

SUBCAB

Mains	Lead	Pump terminal board	Stator lead	Pump terminal board
L1	1 black	U1	U1, red	U1
L2	2 black	W1	W2, black	W2
L3	3 black	V1	V1, brown	V1
L1	4 black	W2	U2, green	U2
L2	5 black	V2	W1, yellow	W1
L3	6 black	U2	V2, blue	V2
Earth (Ground)	Yellow/Green	⊥		
Control	Cable lead			
T1	T1/black*			
T2	T2/black*			

SUBCAB 4G/SUBCAB AWG*

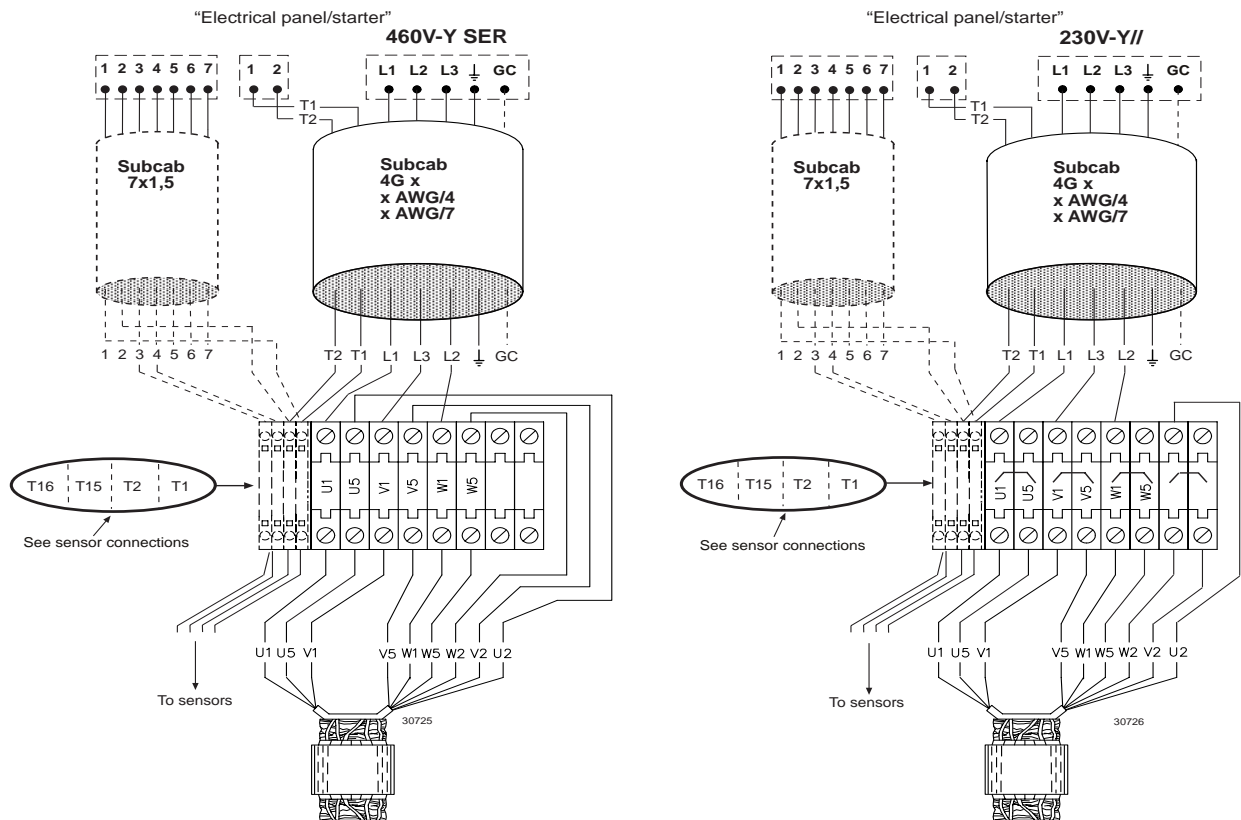

*** SUBCAB AWG**

Mains	Lead	Pump terminal board	Mains	Lead	Pump terminal board
L1	Brown/(Red*)	U1	L1	Brown/(Red*)	U1
L2	Blue (White*)	W1	L2	Blue (White*)	W1
L3	Black (Black*)	V1	L3	Black (Black*)	V1
Earth (Ground)	Yellow/Green	⊥	Earth (Ground)	Yellow/Green	⊥
Groundcheck (GC)	Yellow		Groundcheck (GC)	Yellow	
Stator leads 460V-Y SER connection:			Stator leads 230V-Y// connection:		
Stator lead		Pump terminal board	Stator lead		Pump terminal board
U1, red		U1	U1, red		U1
W2, black		W2	U5, red		U5
V1, brown		V1	V1, brown		V1
U2, green		U2	V5, brown		V5
W1, yellow		W1	W1, yellow		W1
V2, blue		V2	W5, yellow		W5
V5, brown			U2, green		
W5, yellow			V2, blue		
U5, red			W2, black		
Control	Cable lead				
T1	T1/orange*				
T2	T2/blue*				

Sensor connections

Monitoring equipment

The **FLS10** sensor is installed in the inspection chamber and consists of a small float switch.

The FLS10 sensor is connected in series with the stator thermal contacts. They should be connected to an alarm relay, type Mini CAS II, in accordance with the following diagram.

Thermal contacts are incorporated into the stator and may be used for voltages up to 250 V, rated current 10 A (cos φ =1) / 6.3 A (cos φ = 0.6). ITT Flygt recommends that they are connected to 24 V over separate fuses to protect other automatic equipment.

For a **PTC-thermistor** (PTC = Positive Temperature Coefficient), there is a significant increase in resistance at a certain temperature that can be utilized for monitoring the temperature.

PTC-thermistor

T=25 °C $R \leq 100 \text{ Ohm}$

T=135 °C ($T_{REF} - 5 \text{ °C}$) $R \leq 550 \text{ Ohm}$

T=145 °C ($T_{REF} + 5 \text{ °C}$) $R \geq 1330 \text{ Ohm}$

Three thermistors are connected in series and have a resistance of approx. 150-300 ohms at room temperature.

The label in the junction box shows if the pump is equipped with optional sensors.

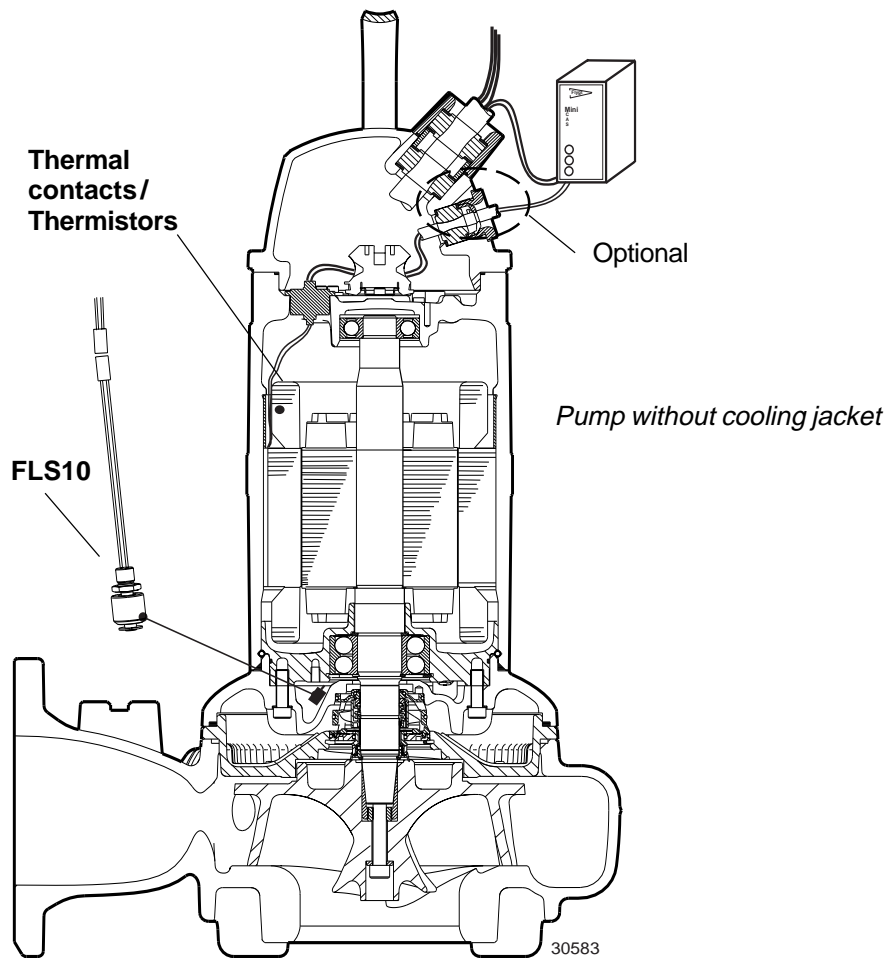

Sensor connection for standard configuration

The pump is as standard equipped with either thermal contacts or thermistors.

A) Thermal contacts

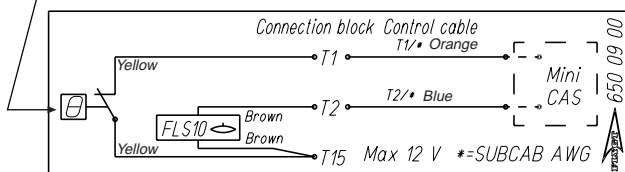

B) Thermistors

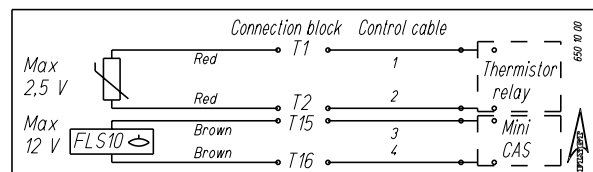

FLS10 + thermal contacts

0 mA = *Overtemperature*

10 mA = *OK*

28 mA = *Leakage*

Tolerance 10%

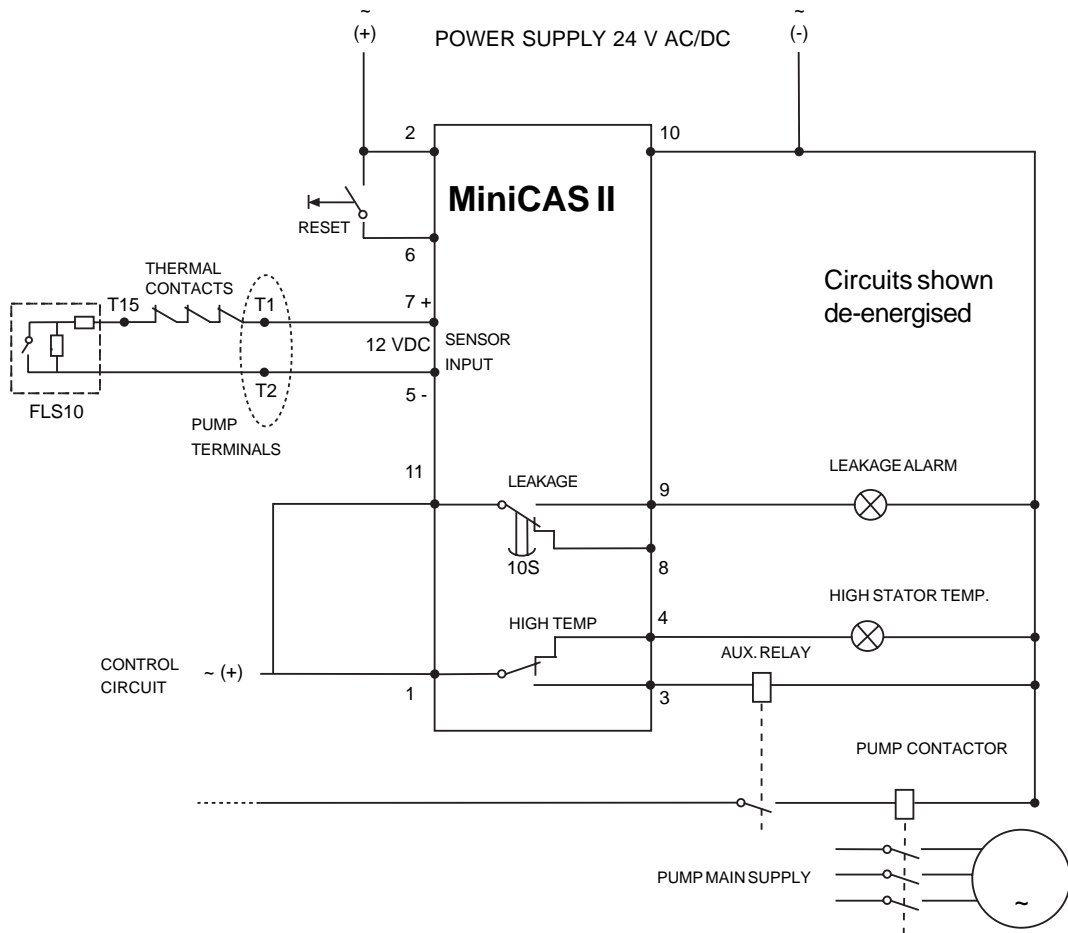

Sensor Connection Table

(For further information please contact Flygt representative.)

Sensor	Sensor lead	Thermal connection	Control cable	Connected to
Thermal contacts + FLS10	White	T1	T1/*Orange	Mini CAS II
	Brown	T2	T2/*Blue	Mini CAS II
	White+Brown	T15	= SubCab /* SubCabAWG	
Thermistors + FLS10	Red	T1	1	Thermistor relay
	Red	T2	2	Thermistor relay
	Brown	T15	3	Mini CAS II
	Brown	T16	4	Mini CAS II

OPERATION

Before starting

Check that the visible parts of the pump and installation are undamaged and in good condition. Remove the fuses or open the circuit breaker and check that the impeller can be rotated freely.

Check that the monitoring equipment works.

Check the direction of rotation. The impeller shall rotate clockwise, as viewed from above. When started, the pump will jerk in the opposite direction to the direction in which the impeller rotates. See figure.

In case of dry installation, check the direction of rotation through the inlet elbow access cover.

Transpose two phase leads if the impeller rotates in the wrong direction (3 ~).



- Before starting work on the pump, make sure that the pump is isolated from the power supply and cannot be energized.



- Make sure that the pump cannot roll or fall over and injure people or damage property.
- In some installations the pump surface and the surrounding liquid may be hot. Bear in mind the risk of burn injuries.
- In some installations and at certain operating points on the performance curve, the noise level of 70 dB or the noise level specified for the actual pump may be exceeded.
- Only Ex-approved pumps may be used in an explosive or flammable environment.

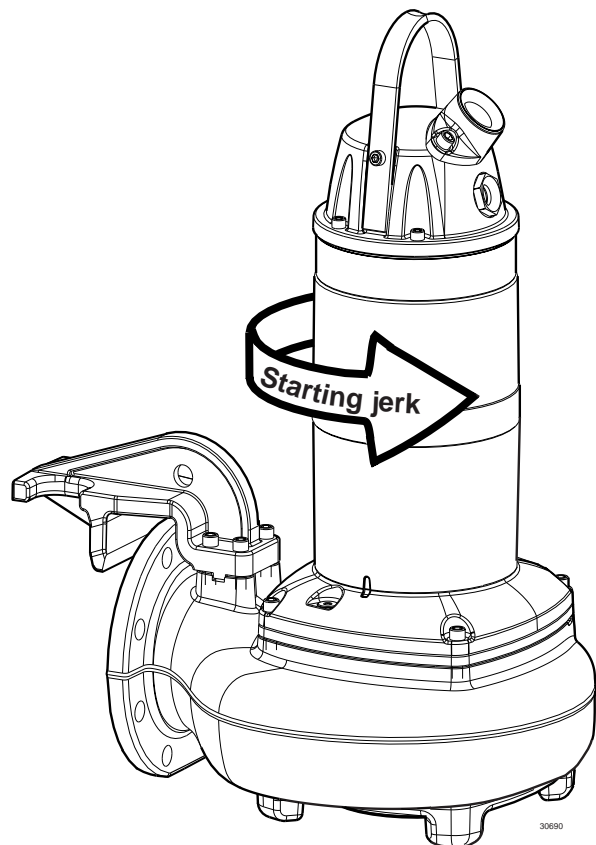

Watch the starting jerk which can be powerful.

CARE AND MAINTENANCE

Service/Inspection

ITT Flygt recommends a preventive maintenance program based on Intermediate and Major Services at regular intervals. For standard sewage applications where FLS 10 is correctly connected and in use and the temperature of the pumped liquid is 40°C (104°F) or less an *Intermediate Service* should be performed every 8000 hours or every 2 years, whichever occurs first.

The time between *Major Service* could vary considerably depending on operating conditions and the need for a Major Service will be determined during the regular Intermediate Services.

However, a minimum of 20 000 hours of operation could be anticipated.

For other applications than sewage water or for specific operating conditions, other service intervals may be recommended.

Pump	Intermediate Service running 8 000 h or 2 years
Junction box	Check that it is clean and dry.
Terminal board	Check that the connections are properly tightened.
Isolation check	Check that the resistance between earth and phase lead is more than 5 M Ω .
Cable	Check that the rubber sheating (jacket) is undamaged.
Seal housing	Fill up with new coolant if necessary. Check freezing point (lower than -13°C, 9°F).
Inspection chamber	Drain all liquid if any. Check the resistance. Normal value approx. 1200 Ω , alarm approx. 430 Ω .
O-rings	Always replace the O-rings of the filling plugs and at the junction cover. Always grease new O-rings.
Thermal contacts	Check the resistance. Normally closed circuit; interval 0 – 1 Ω .
Thermistor	Check the resistance 20 – 250 Ω , (measuring voltage max 2 V DC).
Impeller	Check impeller clearance and adjust if necessary.
Lifting handle	Check the screws and the status of the lifting handle.

Rotation direction	Check the rotation of the impeller.
Lifting device	Check that local safety regulations are followed.
Voltage and amperage	Check running values.
Pumpstation	Intermediate Service running 8 000 h or 2 years
Electrical cabinets/panels	Check that they are clean and dry.
Connection to power	Check that the connections are properly tightened.
Overload and other protections	Check correct settings.
Personnel safety	Check guard rails, covers and other protections.
Level regulators	Check condition and function.

If any indication of alarm between inspections, please see instructions below.	Actions
FLS10	Drain the fluid in the inspection chamber. Fill with new coolant if necessary. Check freezing point (lower than -13°C , 9°F). Check the inspection chamber again after one week of operation. If leakage has occurred, drain the fluid and change the mechanical seal unit and replace with new coolant.
Thermistor/Thermal-contact	Check coolant level. (pump with cooling jacket) Check start and stop levels.
Overload protection	Check that the impeller can rotate freely.

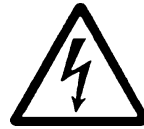

Before starting work on the pump, make sure that the pump is isolated from the power supply and cannot be energized.

This applies to the control circuit as well.

NOTE for Ex version

All work on the explosion-proof motor section must be performed by personnel authorized by Flygt.

Flygt disclaims all responsibility for work done by untrained, unauthorized personnel.

The following points are important in connection with work on the pump:

- Make sure that the pump cannot roll or fall over and injure people or damage property.
- Check every year that the lifting equipment is in good condition.

The pump is designed for use in liquids which can be hazardous to health. In order to prevent injury to the eyes and skin, observe the following points when working on the pump:

- Make sure that the pump has been thoroughly cleaned.
- Beware of the risk of infection.
- Follow local safety regulations.
- Always wear goggles and rubber gloves.
- Rinse the pump thoroughly with clean water before starting work.

- Rinse the components in water after dismantling.
- The coolant chamber may be under pressure. Hold a rag over the filling plug to prevent splatter.

Proceed as follows if hazardous chemicals have splashed into your eyes:

- Rinse your eyes immediately in running water for 15 minutes. Hold your eyelids apart with your fingers.
- Contact an eye specialist.

On your skin:

- Remove contaminated clothes.
- Wash your skin with soap and water.
- Seek medical attention, if required.

Changing the coolant

Emptying coolant (without cooling jacket)

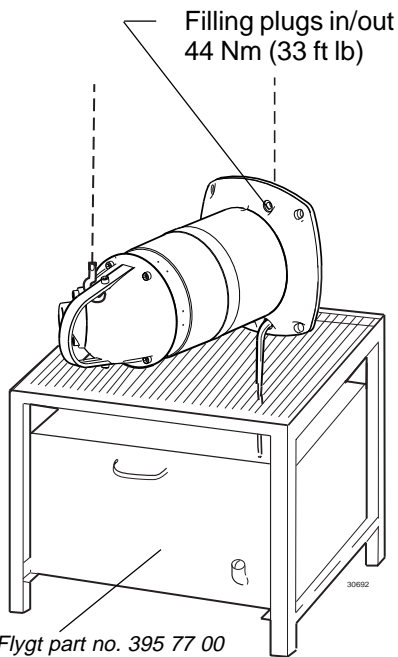

Emptying coolant (with cooling jacket)

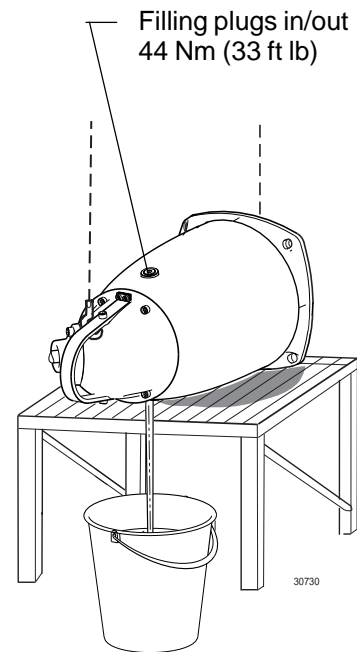

Relief table Flygt part no. 395 77 00

Filling coolant

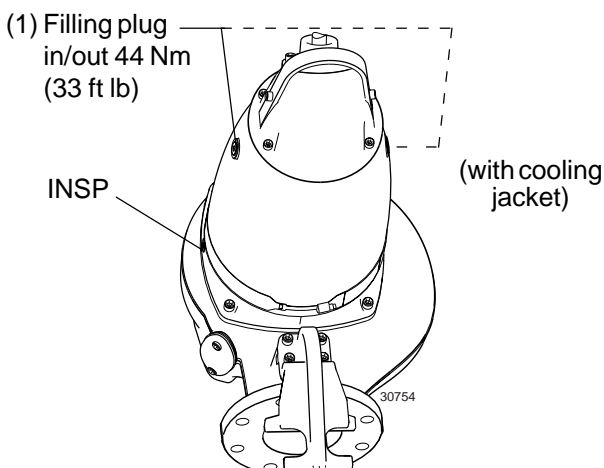
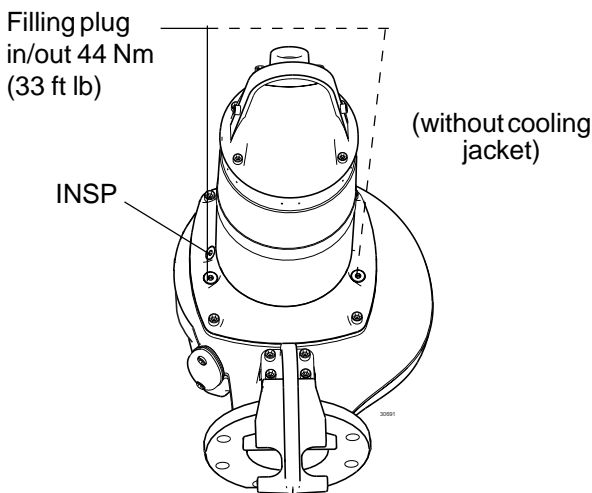

1. Lift the pump horizontally with an overhead crane and place on relief table.

2. Turn the pump so that one of the filling plugs holes faces downwards.

WARNING! If the mechanical seal unit leaks, the seal housing may be under pressure. Hold a rag over the filling plug to prevent splatter.

3. Unscrew the filling plug. It is easier to drain the water-glycol if the other filling plug is also removed.

4. **Pump without cooling jacket.** Raise the pump to an upright position. Fill with coolant to the same level as the filling plugs; approx. 2,2 litres (2.3 US quarts).

Pump with cooling jacket; approx. 10,5 litres (11.2 US quarts)

Coolant: a mix of water and stabilized monopropylene glycol in a mixture ratio of 70/30 % volume part.

Known trade marks of monopropylene glycol are: Dowcal N (individual components are approved by FDA), Dowcal 20. These are non-poisonous, heat-and-cold resistant and inhibiting of corrosion.

Use of other type of glycol jeopardize the function of the pump.

If there is no frostrisk even clean water with anti-corrosive is acceptable as coolant.

5. Always replace the O-rings of the filling plugs. Put the plugs back and tighten them.

Removing the impeller

1.

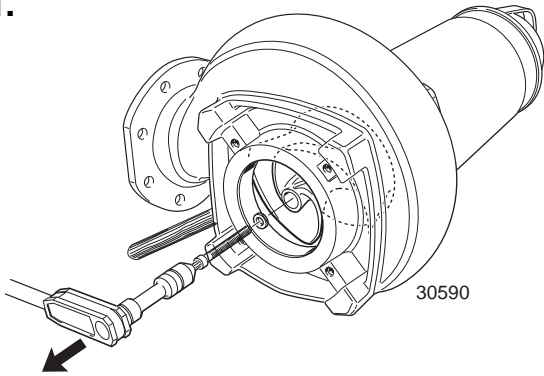

Place the pump horizontally. Remove the flush valve cover and its o-ring. Insert a rod (wood or plastic) through the hole and lock the impeller in place. Remove the impeller screw.

2.

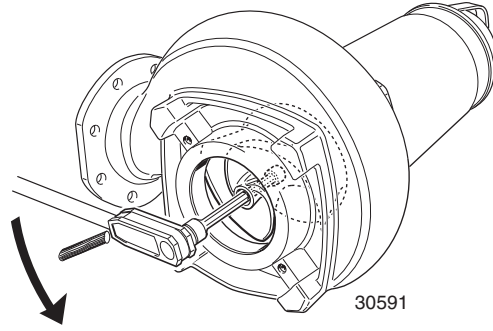

Using a 12 mm hexagon bit adaptor (allen socket) with a 100 mm (4") extension (minimum length) turn the gland screw counter clockwise until the impeller breaks free from the shaft.

3.

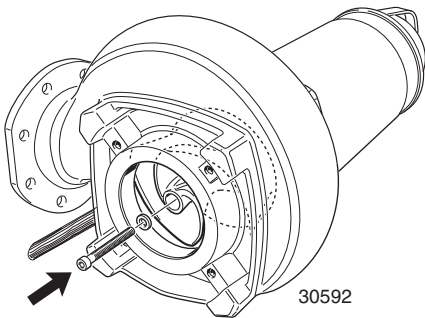

Install the impeller screw. Tighten lightly by hand, just to prevent the impeller from falling off.

4.

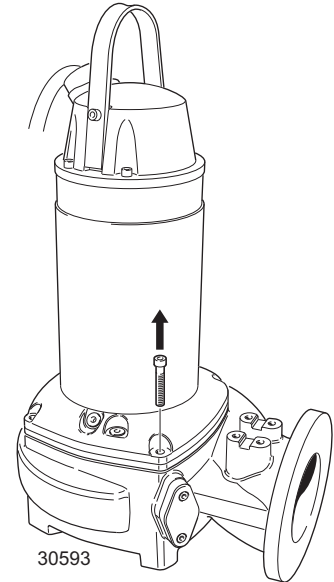

Remove the rod and raise the pump. Remove the pump housing screws. Using a crane, lift the drive unit off the pump housing.

5.

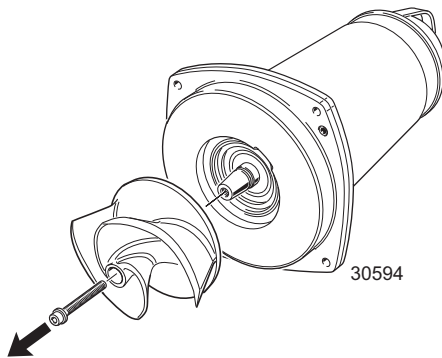

Place the drive unit horizontally. Remove the impeller screw.



Worn impellers can have very sharp edges. Use protective gloves!

WARNING! When laying the pump on its side do not allow the weight of the pump to rest on any portion of the impeller. The impeller must not be allowed to make contact with the concrete floor or other hard and rough surfaces.

Installing the impeller

1.

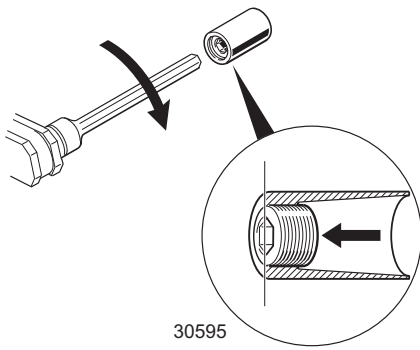

Make sure that the end of the shaft is clean and free from burrs. Polish off any flaws with fine emery cloth. Grease end of shaft, conical sleeve and the threads of the gland screw and the impeller screw. Align the edge of the gland screw with the edge of the conical sleeve so that they are flush.

2.

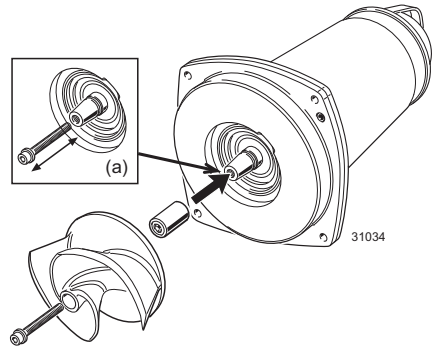

Before assembling, check that the impeller screw is clean and easy to screw into the shaft end (a). This to prevent the shaft to rotate with the impeller screw. Assemble the conical sleeve and the impeller onto the shaft. Fit the impeller screw onto the shaft. Tighten the impeller screw lightly by hand, just to prevent the impeller from falling off.

3.

Fit the drive unit to the pump housing. Adjust its position so that the inspection hole is on the same side as the hole for the flush valve. Tighten the screws in diagonally opposite pairs.

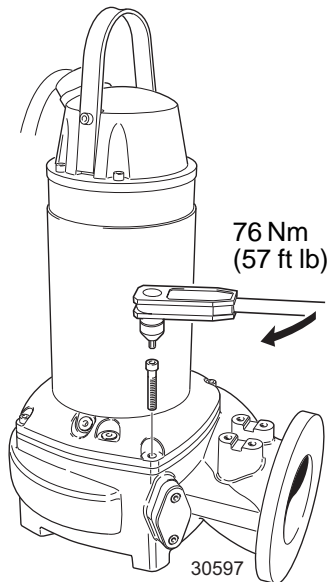

4.

Place the pump horizontally. Remove the flush valve cover and its o-ring. Insert a rod (wood or plastic) through the hole and lock the impeller in place. Remove the impeller screw.

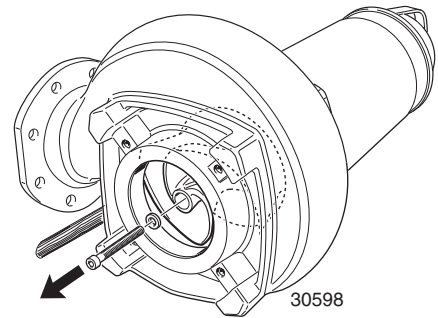

5.

B:
+
1/8
turn
(45°)

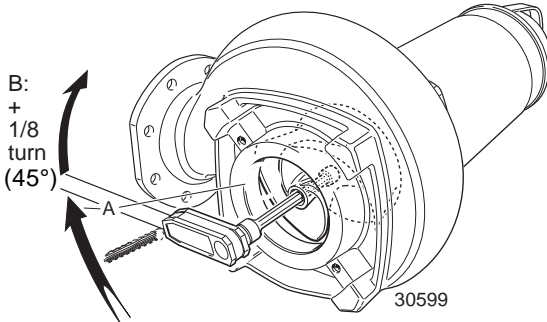

Turn the gland screw clockwise until the impeller makes contact with the pump housing. Tighten it a further 1/8 turn, 45°. This will insure the correct clearance between the impeller and the bottom of the pump housing in the next step.

6.

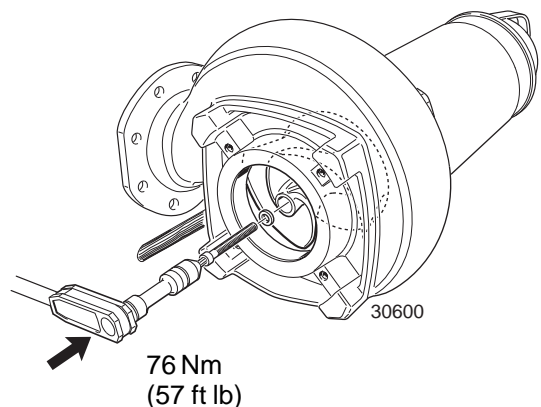

Fit the washer and the greased impeller screw and tighten, torque to 76 Nm (57 ft lb). Remove the rod used to lock the impeller. Fit the o-ring, flush valve cover and secure with screws, torque to 44 Nm (33 ft lb).

FAULT TRACING (TROUBLESHOOTING)

A universal instrument multimeter (VOM), a test lamp (continuity tester) and wiring diagram are required in order to carry out fault tracing on the electrical equipment.

Fault tracing shall be done with the power supply disconnected and locked off, except for those checks which cannot be performed without voltage.

Always make sure that there is no one near the pump

when the power supply is turned on.

Use the following checklist as an aid to fault tracing. It is assumed that the pump and installation have formerly functioned satisfactorily.

Electrical work shall be performed by an authorized electrician.

Follow local safety regulations and observe recommended safety precautions.

1. Pump fails to start

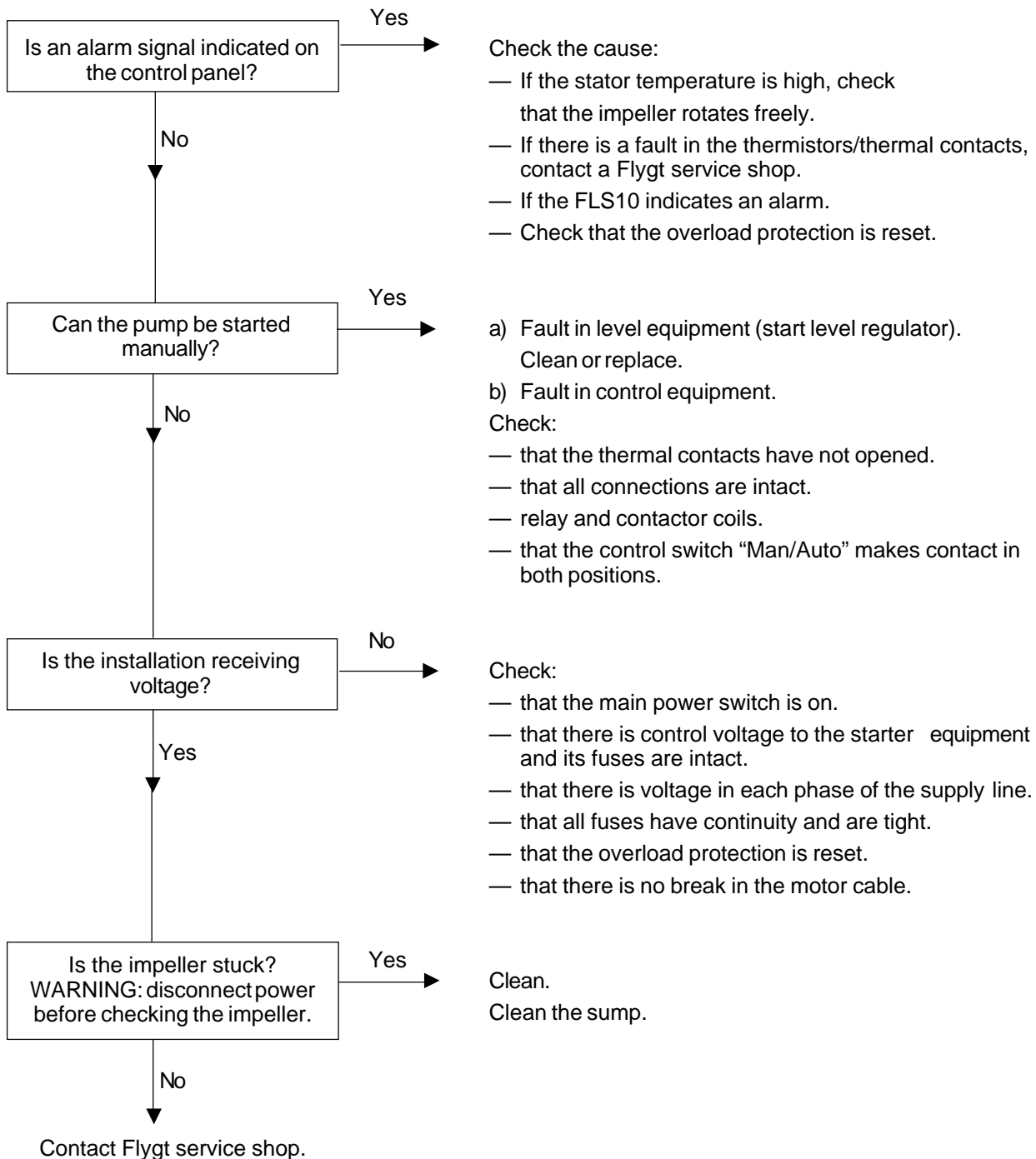

2. Pump starts but motor protection trips

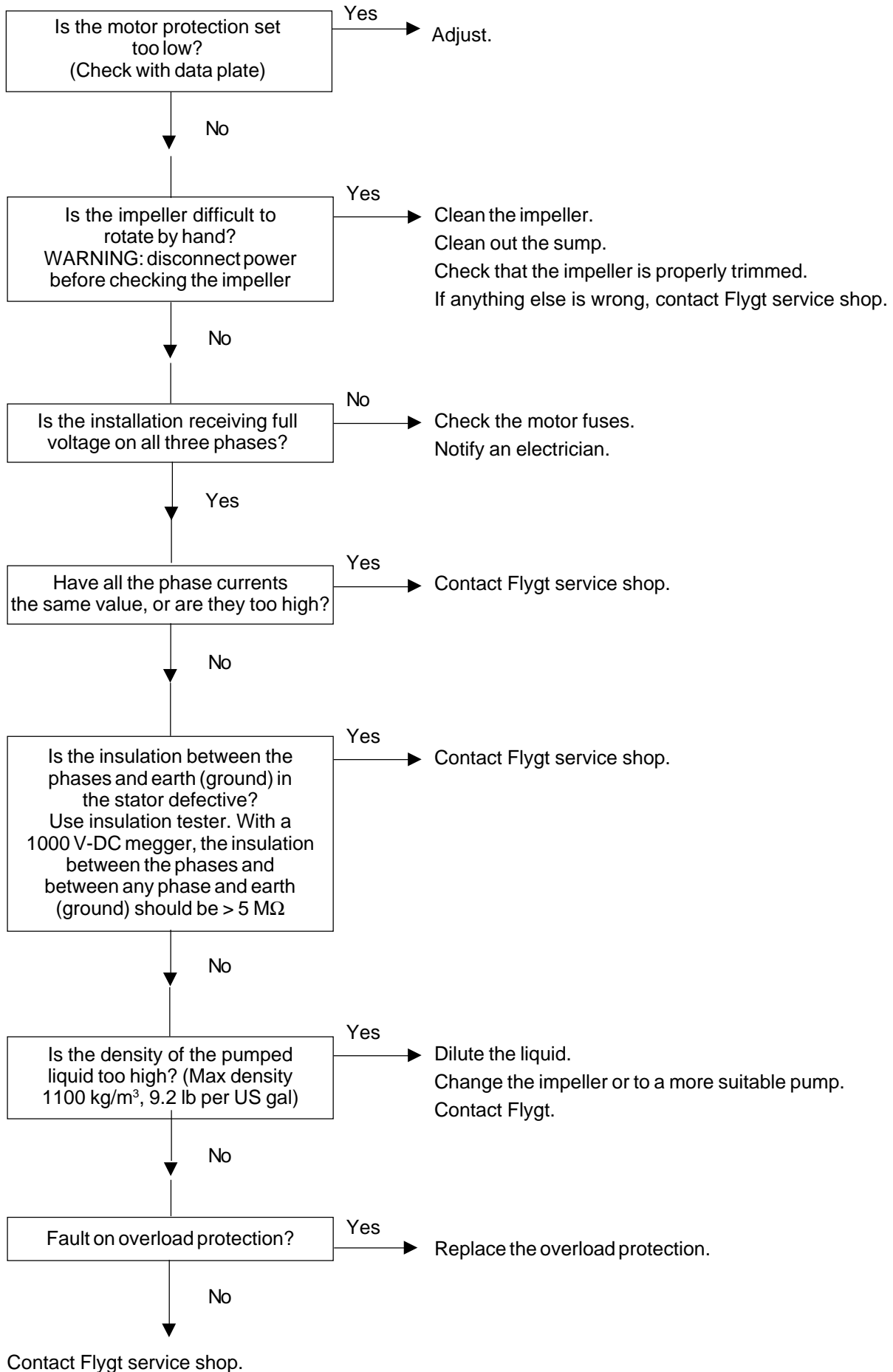

3. The pump does not stop (when level control is used)

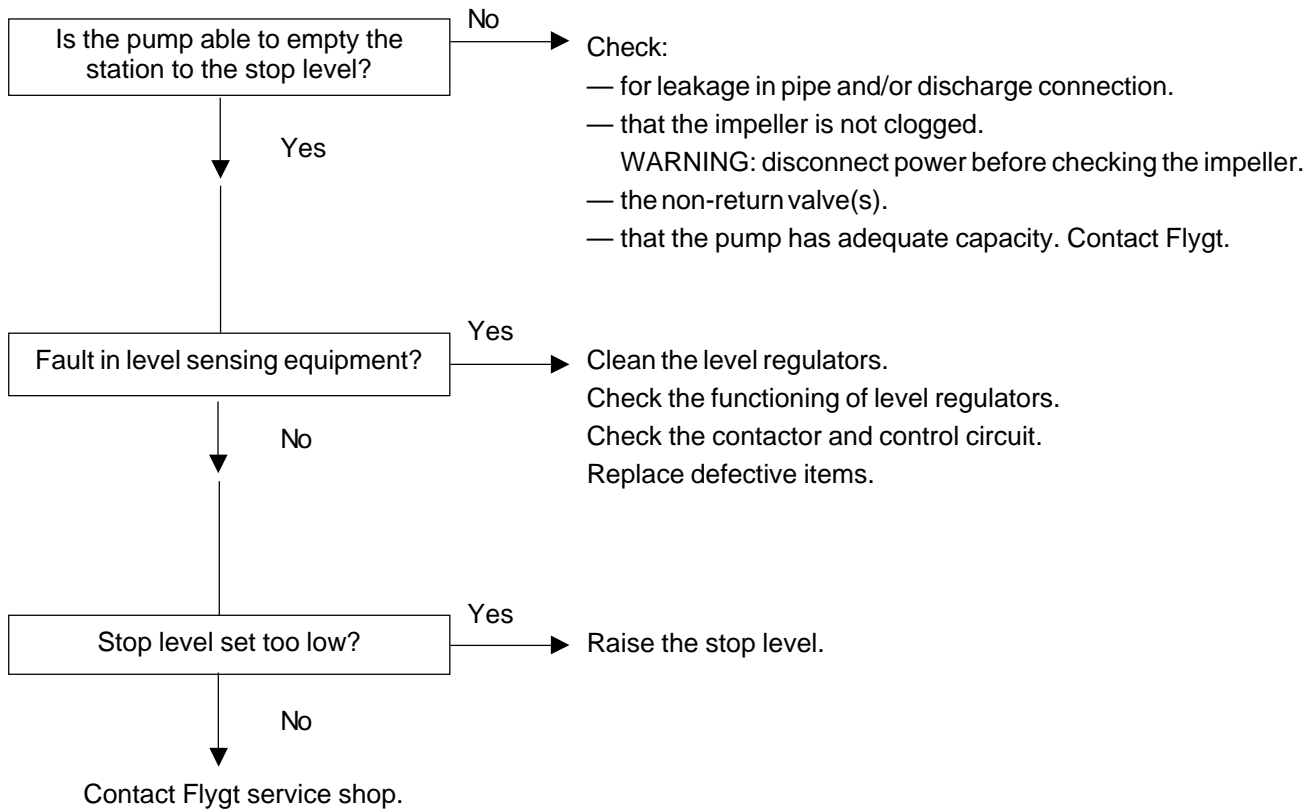

4. The pump starts-stops-starts in rapid sequence

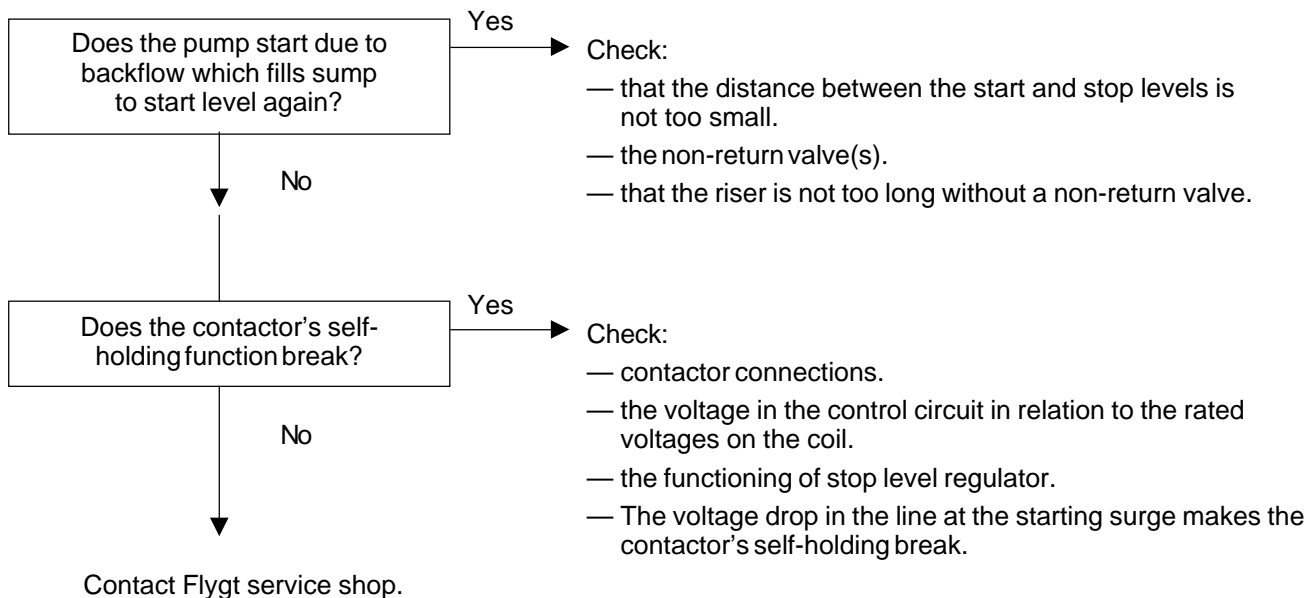

5. Pump runs but delivers too little or no water

Check:

- direction of rotation of pump, see "Before starting".
- that valves are open and intact.
- that pipes and impeller are not clogged.
- that the impeller rotates freely.
- that the suction lift has not been altered.
- for leakage in the pump installation.
- for wear on the impeller, pump and casing/flange.

See also under "Inspection".

Do not override the motor protection repeatedly if it has tripped.

SERVICE LOG

Most recent service date	Pump No.	Hours of operation	Remarks	Sign.



www.flygt.com