



Installation, care and maintenance

3080.590/690/790



Flygt



ITT Industries

GUARANTEE

Flygt undertakes to remedy faults in products sold by Flygt provided:

- that the fault is due to defects in design, materials or workmanship;
- that the fault is reported to Flygt or Flygt's representative during the guarantee period;
- that the product is used only under conditions described in the care and maintenance instructions and in applications for which it is intended;
- that the monitoring equipment incorporated in the product is correctly connected;
- that all service and repair work is done by a workshop authorized by Flygt;
- that genuine Flygt parts are used.

Hence, the guarantee does not cover faults caused by deficient maintenance, improper installation, incorrectly executed repair work or normal wear and tear.

Flygt assumes no liability for either bodily injuries, material damages or economic losses beyond what is stated above.

Official approval applies only providing:

- that the product is used under conditions described in the care and maintenance instructions and in applications for which it is intended;
- that the monitoring equipment incorporated in the product is correctly connected;
- that all service and repair work is done by a workshop authorized by Flygt;
- that genuine Flygt parts are used.

Flygt guarantees that a spare parts stock will be kept for 10 years after the manufacture of this product has been discontinued.

The manufacturer reserves the right to alter performance, specification or design without notice.

CONTENTS

Data plates interpretation _____	3	Operation _____	9
Product description _____	4	Before starting _____	9
Applications _____	4	Care and maintenance _____	10
Dimensions and weight _____	4	Safety precautions _____	10
Motordata _____	4	Inspection _____	10
Design _____	4	Changing the oil _____	13
Technical data _____	5	Accessories and tools _____	18
Transportation and storage _____	6	Fault tracing (Troubleshooting) _____	19
Installation _____	6	Service log _____	22
Safety precautions _____	6	Exploded view _____	23
Pump installation _____	6		
Electrical connections _____	7		

DATA PLATES INTERPRETATION

GENERAL DATA PLATE

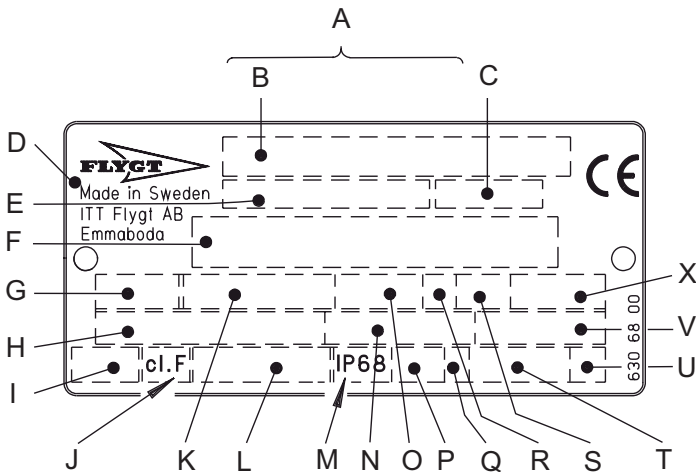

- A Serial number
- B Product code + Number
- C Curve code / Propeller code
- D Country of origin
- E Product number
- F Additional information
- G Phase; Type of current; Frequency
- H Rated voltage
- I Thermal protection
- J Thermal class
- K Rated shaft power
- L International standard
- M Degree of protection
- N Rated current
- O Rated speed
- P Max. submergence
- Q Direction of rotation: L=left, R=right
- R Duty class
- S Duty factor
- T Product weight
- U Locked rotor code letter
- V Power factor
- X Max. ambient temperature

Special approved pump

590: EEx de IIB T3

690: EEx de I

790: EEx de IIB T3

790: MSHA

APPROVAL PLATES

Always together with the general data plate

EN-data plate

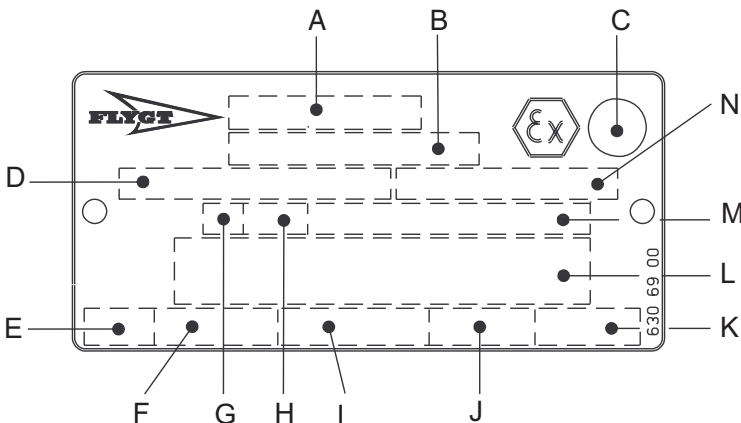

- A Approval
- B Approval authority + Approval Number
- C Approval for Class I
- D Approved drive unit
- E Stall time
- F Starting current; Rated current
- G Duty class
- H Duty factor
- I Input power
- J Rated speed
- K Controller
- L Additional information
- M Max. ambient temperature
- N Serial number

PRODUCT DESCRIPTION

These care and maintenance instructions apply to an submersible Flygt pump.

Applications

3080 is intended to be used for pumping of water which may contain abrasive particles

The pump is designed for use in explosive environments in accordance with the following approval:

European Norm

590, 790:

— 50014, 18, 19 EEx de II T3, MSHA 2G-3791A-0

690:

— 50014, 18, 19 EEx de I

Liquid temperature: max. 40°C (105°F)

Liquid density: max. 1100 kg/m³ (9.2 lb per US gal.)

The pumped liquid may contain particles up to a size which corresponds to the throughlet of the pump.

The pH of the pumped liquid:

590, 690 = 6—11.

790 = 5—8.

Depth of immersion: max. 20 m (66 ft).

For other applications, contact your nearest Flygt representative for information.

Dimensions and weights

All dimensions are in mm (in).

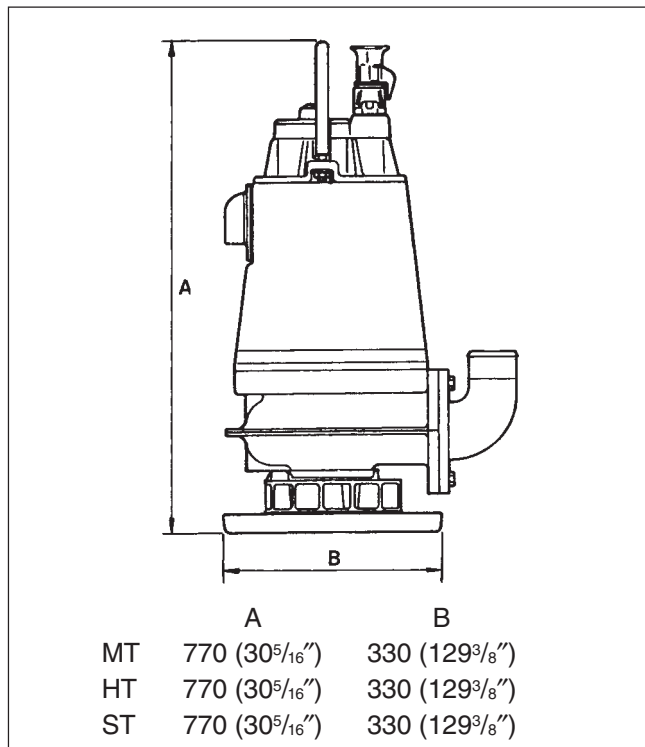

Weight without motor cable in kg (lb)

3080.590.690: 100 (220.5)

3080.790: 60 (121.25)

Motordata

Rated output:
4,0 kW, 3 ~, 50 Hz, 1400 r/min

Voltage V	Rated current A	Starting current A
220	15.2	62.0
380	8.8	46.0
400	8.4	32.0
415	8.0	33.0
440	7.6	35.0
500	6.8	28.0
550	6.1	25.0
1000	3.4	14.0

Rated output:
5.2 kW, 3 ~, 50 Hz, 2800 r/min

Voltage V	Rated current A	Starting current A
220	19.3	99.0
380	11.2	57.0
400	10.6	27.0
415	10.2	27.0
440	9.7	28.5
500	8.5	21.0
550	7.7	24.0
1000	4.3	11.0

Rated output:
6.5 HP (4.8 kW), 3 ~, 60 Hz,
1600 r/min (MSHA only)

Voltage V	Rated current A	Starting current A
220	19.0	72.0
440	9.5	36.0
575	7.3	26.0
600	6.7	29.0

Rated output:
9.0 HP (6.6 kW), 3 ~, 60 Hz,
3300 r/min (MSHA only)

Voltage V	Rated current A	Starting current A
230	25.0	112.0
440	13.0	62.0
460	12.5	52.0
575	10.0	38.0

Design

3080 is a submersible, electric motordriven pump.

Impellers

Multi vane impeller of Ni-hard alloy.

Shaft seals

The pump has two mechanical seals.

Materials:

Inner seal: tungsten carbide—carbon.

Outer seal: tungsten carbide—tungsten carbide.

Shaft

The shaft is delivered with the rotor as an integral part.

The shaft is completely sealed and will not come into contact with the pumped liquid.

Shaft material: stainless.

Bearings

The pump bearings are designed for at least 10 000 hours of operation.

The lower bearing consists of MT: one angular contact ball bearing.

HT, ST: two angular contact ball bearings.

The upper bearing consists of one single row ball bearing.

Oil casing

The oil lubricates and cools the seals and acts as a buffer between the pump casing and the electric motor.

Pressure build-up within the oil casing is reduced by means of a built-in air volume.

Motor

Squirrel-cage 3-phase induction motor for 50 Hz or 60 Hz.

The motor is started by means of direct on-line start

The motor can be run continuously or intermittently with a maximum of 15 evenly spaced starts per hour.

The stator is insulated in accordance with class F (155°C, 310°F). The motor is designed to supply its rated output at ± 5 % variation of the rated voltage.

Without overheating the motor, ± 10 % variation of the rated voltage can be accepted provided that the motor does not run continuously at full load. The motor is designed to operate with a voltage imbalance of up to 2 % between the phases.

Monitoring equipment

The stator incorporates three thermal switches connected in series.

On EN-versions the thermal switches opens at:

MT, HT: 110°C (230°F)
ST: 115°C (240°F)

On MSHA-versions the thermal switches opens at 125°C (257°F).

The monitoring equipment shall be of a design that makes automatic restart impossible.

See also “Electrical connections” and separate instructions for starter equipment.

Cooling

The stator is cooled by the circulation of a portion of the pumped liquid in the space between the stator casing and the cooling jacket.

Technical data

The pump curves show:

- input power at various operating points.
- flow rate versus total head.

The following abbreviations are used:

- MT = medium-head version
- HT = high-head version
- ST = super-head version

For further information, see “Parts list”.

50 Hz

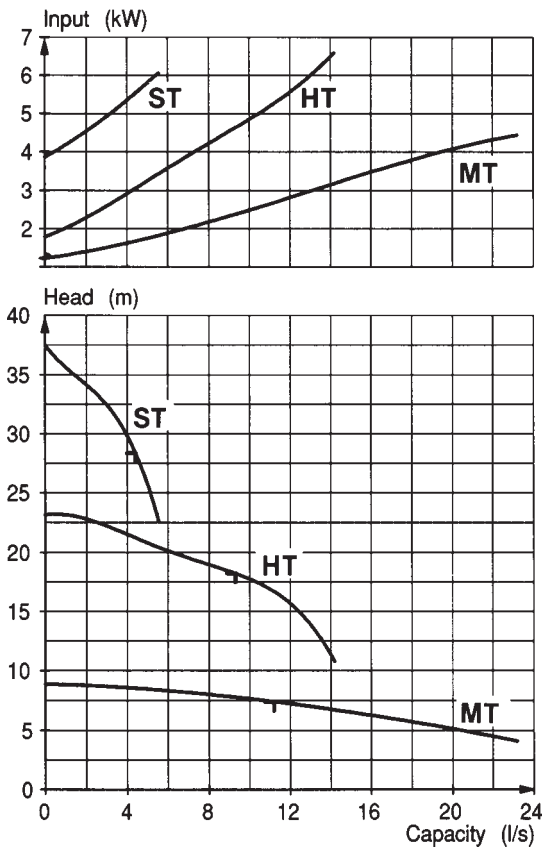

60 Hz For MSHA only

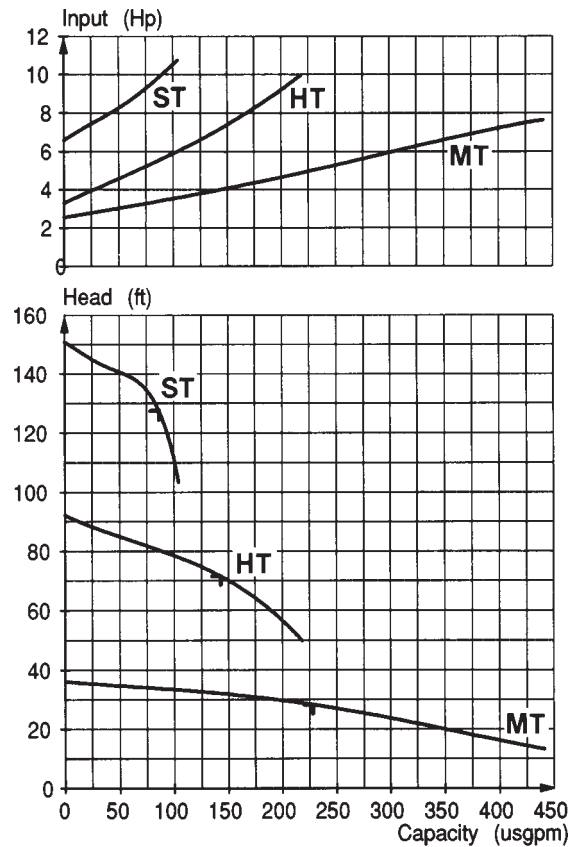

TRANSPORTATION AND STORAGE

The pump may be transported and stored in a vertical or horizontal position. Make sure that it cannot roll or fall over.



WARNING!
Always lift the pump by its carrying handle or lifting eyes, never by the motor cable or the hose.

The pump is frostproof as long as it is operating or is immersed in the liquid. If the pump is taken up when the temperature is below freezing, the impeller may freeze. The pump shall be operated for a short period after being taken up in order to expel all remaining water.

A frozen impeller can be thawed by allowing the pump to stand immersed in the liquid for a short period before it is started. Never use an open flame to thaw the pump.

For longer periods of storage, the pump must be protected against moisture and heat. The impeller should be rotated by hand occasionally (for example every other month) to prevent the seals from sticking together. If the pump is stored for more than 6 months, this rotation is mandatory.

After a long period of storage, the pump should be inspected before it is put into operation. Pay special attention to the seals and the cable entry.

During a longer period out of operation, the pump shall be test-started every other month to prevent the mechanical seals from sticking together.

Follow the instructions under the heading "Before starting".

INSTALLATION

Safety precautions

In order to minimize the risk of accidents in connection with the service and installation work, the following rules should be followed:

1. Make sure the lifting equipment is in good condition.
2. Be aware of the risk of electrical accidents.
3. Use a safety helmet, safety goggles and protective shoes.

Follow all other health and safety rules and local codes and ordinances.



WARNING!
At certain installations and operation points on the pump curve the noise level 70 dB, or for the actual pump specified noise level, can be exceeded.

Pump installation

Run the cables so that they do not have any sharp bends and are not pinched.

Connect the discharge connection and motor cable. See "Electrical connections".

Lower the pump into the sump.

Place the pump on a base which will prevent it from sinking into a soft sump bottom. Alternatively, the pump can be suspended by its handle just above the sump bottom.

For tandem connection of pumps, see "Accessories and tools".

Consult your nearest Flygt representative regarding:

- choice of peripheral equipment.
- other problems in connection with installation.

ELECTRICAL CONNECTIONS

All electrical work shall be carried out under the supervision of an authorized electrician.

Local codes and regulations shall be complied with.



NOTE for Ex version
All work on the explosion-proof motor section must be performed by authorized Flygt personnel or personnel authorized by Flygt.

Check that the mains voltage and frequency agree with the specifications on the pump data plate.

The motor can be connected for different voltages as shown on the data plate.

Under no circumstances may the starter equipment be installed in the pump pit.

Install the motor cable and the control cable as illustrated in the figure.

To avoid leakage into the pump, check:

— that the cable entry seal sleeve and washers conform to the outside diameter of the cable. See the parts list.

— that the outer jacket on the cable is not damaged. When refitting a cable which has been used before, **always** cut off a short piece of the cable so that the cable entry seal sleeve does not close around the cable at the same point again.



NOTE!
For safety reasons, the earth lead should be approx. 90 mm (3.5") longer than the phase leads. If the motor cable is jerked loose by mistake, the earth lead should be the last lead to come loose from its terminal. This applies to both ends of the cable.

Check on the data plate which connection, Y or Δ , is valid for the voltage supply. Then, depending on voltage, arrange the connection on the terminal board in accordance with Y or Δ .

Connect the motor cable to the terminal board connections U1, V1, W1 and earth.

Connect the leads from the motor control circuit to T1 and T2.

Make sure that the pump is correctly earthed (grounded).

Install the cover (112).

Tighten the screws (7) and the cable entry (56) so that the cable entry unit bottoms out.

Connect the motor cable and the control cable to the starter equipment. Check the direction of rotation, see "Before starting".

If the direction of rotation is wrong, transpose two of the phase leads.

Remember that the starting surge with the direct-on line start can be up to six times higher than the rated current. Make sure that the fuses or circuit breakers are of the proper amperage.

The table (see page 4) gives rated current and starting current. Fuse amperage and cable shall be selected in accordance with local rules and regulations. Note that with long cables, the voltage drop in the cable must be taken into consideration, since the motor's rated voltage is the voltage that is measured at the terminal board in the pump.

The overload protection (motor protection breaker) shall be set to the motor's operating current, but no higher than the motor's rated current as given on the data plate.

Motor cable connection

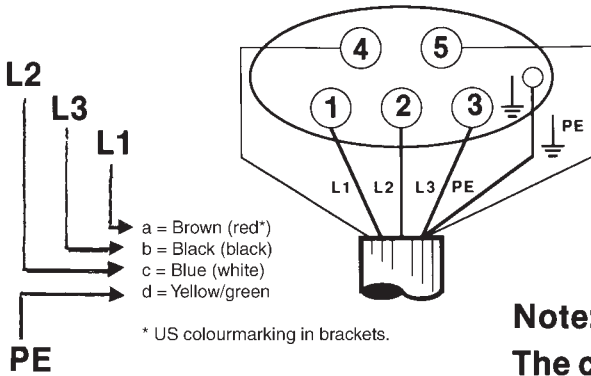

The stator leads are colourmarked as follows:

- U1 — red
- V1 — brown
- W1 — yellow
- U2 — green
- V2 — blue
- W2 — black
- U5 — red
- V5 — brown
- W5 — yellow
- U6 — green
- V6 — blue
- W6 — black

Note:
The connection 6
will remain unused!

Stator connection

D connection

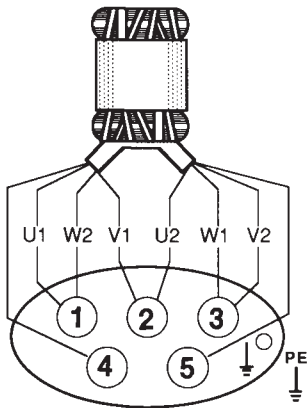

Y connection

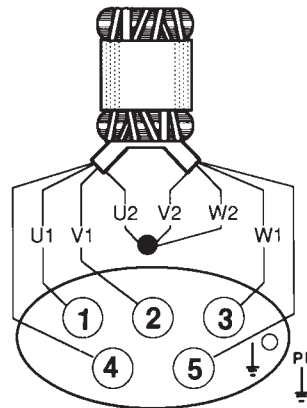

D // connection
 500 - 550 V 50 Hz
 stator variant 56

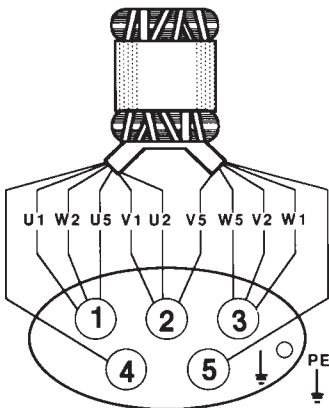

Y // connection
 500 V 50 Hz
 550 V 60 Hz
 stator variant 59

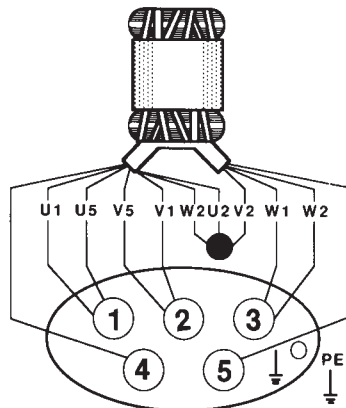

D ser. connection
 1000 - 1100 V 50 Hz
 stator variant 56

Y ser. connection
 1000 V 50 Hz
 1100 V 60 Hz
 stator variant 59

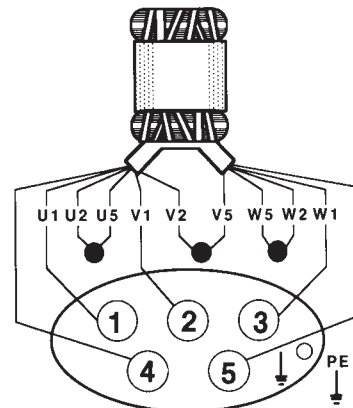

OPERATION

Before starting

Check the oil level in the oil casing.

Remove the fuses or open the circuit breaker and check that the impeller can be rotated by hand.

Check that the monitoring equipment (if any) works.

Check the direction of rotation. See the figure. The impeller shall rotate clockwise, as viewed from above. When started, the pump will jerk in the opposite direction to the direction in which the impeller rotates.



WARNING!
Watch out for the starting jerk,
which can be powerful.

The above measures are described under "Inspection".

Starting jerk

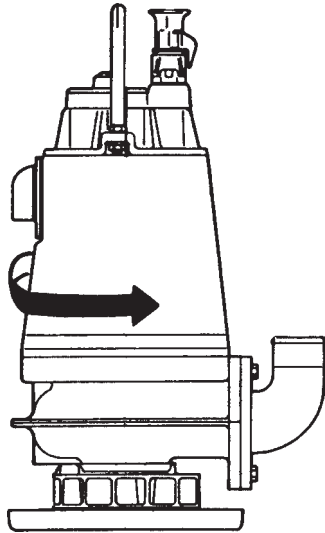

In order to avoid sedimentation when the pumped liquid contains solid particles, the velocity of the medium in the discharge line should be:

Mixture	Min. velocity in discharge line
1. Water + coarse gravel	4 m/s (13.2 ft/s)
2. Water + gravel	3.5 m/s (11.5 ft/s)
3. Water + sand	
Sand particles <0,1 mm (0.004 in)	1.5 m/s (5.0 ft/s)
Sand particles <0,6 mm (0.024 in)	2.5 m/s (8.2 ft/s)

Choose dimension of the discharge line to give the pumped liquid at least this velocity.

The pump can be provided with level regulation in order to prevent unnecessary wear on the hydraulic components.

Cleaning

If the pump has been running in very dirty water, let it run for a while in clean water, or flush it through the discharge connection. If clay, cement or other similar dirt is left in the pump it may clog the impeller and seal preventing the pump from working.

During a longer period out of operation, the pump must be test run every other month to prevent the mechanical seals from sticking together.

CARE AND MAINTENANCE

The figures in parentheses are item numbers and refer to the cutaway figure.



NOTE for Ex version
All work on the explosion-proof motor section must be performed by authorized Flygt personnel or personnel authorized by Flygt. Flygt renounces all responsibility for work done by untrained, unauthorized personnel.

Safety precautions



Before starting work on the pump, make sure that the pump is isolated from the power supply and cannot be energized.

NOTE! This applies to the control circuit as well.

The following points are important in connection with work on the pump:

- make sure that the pump has been thoroughly cleaned.
- observe good personal hygiene.
- beware the risk of infection.
- follow local safety regulations.

Inspection

Regular inspection and preventive maintenance ensure more reliable operation.

The pump should be inspected at least twice a year, more frequently under severe operating conditions.

Under normal operating conditions, the pump should have a major overhaul in a service shop once a year.

This requires special tools and should be done by an authorized service shop.

When the pump is new or when the seals have been replaced, inspection is recommended after one week of operation.

Service contract

Flygt or its agent offers service agreements in accordance with a preventive maintenance plan. For further information, please contact your Flygt representative.

Recommended inspections

Inspection of	Action
Visible parts on pump and installation	<p>Replace or fix worn and damaged parts. Make sure that all screws, bolts and nuts are tight.</p> <p>Check the condition of carrying handle.</p>
Pump casing and impeller	<p>Replace worn parts if they impair function.</p> <p>If the clearance between the impeller skirt and the pump casing exceeds 2 mm, see “Replacing the wear ring”.</p> <p>Wear on the impeller and the parts around it necessitates fine adjustment of the impeller or replacement of worn parts. See “Replacing the impeller” and “Replacing the diffuser”.</p>
Oil quantity	<div style="border: 1px solid black; padding: 5px;">  <p>WARNING. If the seal leaks, the oil casing may be under pressure. Hold a rag over the oil casing screw in order to prevent splatter. See “Safety precautions” for additional information.</p> </div> <p>Check that the oil reaches up to the oil hole.</p>
Condition of the oil	<p>A check of the condition of the oil can show whether there has been an increased leakage. Note! Air/oil mixture can be confused with water/oil mixture.</p> <p>Insert a tube (or hose) into the oil hole. Cover the top end of the tube and take up a little oil from the bottom.</p> <p>Change the oil if it contains too much water, i.e., is heavily emulsified (cream-like), or if the oil housing contains separated water. See “Changing the oil”. Check again one week after changing the oil.</p> <p>If the oil contains too much water again, the fault may be:</p> <ul style="list-style-type: none"> — that an oil screw (61) is not sufficiently tight. — that the O-ring (26) of an oil screw or its sealing surface is damaged. — that an O-ring (42, 43) or its sealing surface is damaged. — that the lower mechanical seal (63) is damaged. Contact a Flygt service shop.
Cooling system	<p>Rinse and clean if the flow through the system has been partly restricted.</p>
Cable entry	<p>Make sure that the cable clamps are tight. If the cable entry leaks:</p> <ul style="list-style-type: none"> — check that the entry is firmly tightened into its bottom-most position. — cut a piece of the cable off so that the seal sleeve (72) closes around a new position on the cable. — replace the seal sleeve (72). — check that the seal sleeve (72) and the washers (106) conform to the outside diameter of the cables.
Cables	<p>Replace the cable if the outer jacket is damaged. Make sure that the cables do not have any sharp bends and are not pinched.</p>

Inspection of	Action
Level sensors or other level equipment	<p>Check function. Clean, adjust, replace or repair damaged level sensing equipment. Follow the instructions for the level sensing equipment in question.</p> <p>NOTE! The level sensor contains a mercury switch. Damaged sensors should therefore be disposed of in a proper manner.</p>
Starter equipment	If faulty, contact an electrician.
Rotation direction of pump (requires voltage)	<p>Transpose two phase leads if the impeller does not rotate clockwise as viewed from above. Rotation in the wrong direction reduces the capacity of the pump and the motor may be overloaded. Check the direction of rotation, during non-load every time the pump is reconnected.</p>
Pipes, valves and other peripheral equipment	Repair faults and notify supervisor of any faults or defects.
Insulation resistance in the stator	Use insulation tester. With a 1000 V-DC megger the insulation between the phases and between any phase and earth (ground) should be > 1 M Ω.

Changing the oil

Oil casing



WARNING!
If the seal leaks, the oil casing may be under pressure. Hold a rag over the oil plug to prevent splatter.

Lay the pump on its side on a bench or over two supports.

Remove the screw (6) and the locking washer (67).

Unscrew the oil casing screw (61).

Turn the pump so that the oil hole faces downwards. It is easier to drain the oil if the other other oil hole screw is also removed.

Fill up with 0.6 litres (0.6 US quarts) of new oil. Use an ordinary SAE 10W-30 motor oil. Always replace the O-rings of the oil hole screws. Put the screws back and tighten them.

A paraffin oil approved by authorities (e.g. Mobil Whiterex 309) is recommended for raw or clean water pumping.



Removing the impeller and wear parts



WARNING!
Worn impellers often have very sharp edges.

Lay the pump on its side.

Loosen screws (5) and remove the stand.



Loosen the screws (15) and remove the discharge connection (71).



Remove the nuts (16), the washers (21) and the screws (4).



Split the pumpcasing by removing the lower half (88).



The rubber lining (94) can now be replaced.



Prepare removing of the impeller by picking off the rubber hood (92) with a screw driver.



Loosen the nuts (16).



Knock carefully on the upper pump casing to remove it.



The wear ring (91) can now be replaced, first remove the upper rubber lining (93).



The rubber wear part can be prized of with for example a screw driver.



Remove the impeller nut (18). Use a pliers to hold the impeller.



Pull off the impeller. Use a puller or pry off carefully with two strong screwdrivers or bars.



Installing the impeller

Make sure that the end of the shaft is clean and free of burrs. Polish off any flaws with fine emery cloth. Clean and oil all sealing surfaces and O-rings. Check that the cover plate (85) is on its right place in the upper pump casing.



Fit the upper pump casing (87).

Check that the key (2) is seated in the keyway on the shaft.

Grease the end of shaft and impeller hub.

Press the impeller onto the shaft with the impeller nut.



Tighten the impeller nut (18).

Tightening torque 40 Nm.

Fit the protector (92).

Check that the impeller can be rotated by hand.



Fit the lower pump casing (88).



Finally fit the stand (78).



ACCESSORIES AND TOOLS

Tandem operation

The delivery head can be increased by connecting two or three pumps in tandem.

Max. permissible operating pressure is 1 MPa.

The vertical distances between the pumps should be approximately equal.

See special brochure that describes the procedure for tandem connection.

Zinc anode set

In order to reduce corrosion on the pump, it can be fitted with zinc anodes.

Order No. 443 01 00

Start and control equipment

Flygt has suitable start and control equipment for the pump. Contact Flygt for further information.

Tools

Besides ordinary standard tools, the following tools are required in order to perform the necessary care and maintenance of the pump:

Order No.	Description
84 13 60	Puller
84 20 49	Puller
84 15 66	Torque wrench
398 22 00	Seal tool

For further information on tools, see Flygt's Tool Catalogue.

FAULT TRACING (Troubleshooting)

A universal instrument (VOM), a test lamp (continuity tester) and a wiring diagram are required in order to carry out fault tracing on the electrical equipment.

Fault tracing shall be done with the power supply disconnected and locked off, except for those checks which cannot be performed without voltage.

Always make sure that there is no one near the pump when the power supply is turned on.

Use the following checklist as an aid to fault tracing. It is assumed that the pump and installation have formerly functioned satisfactorily.



Electrical work should be performed by an authorized electrician.

Follow local safety regulations and observe recommended safety precautions.

1. Pump fails to start

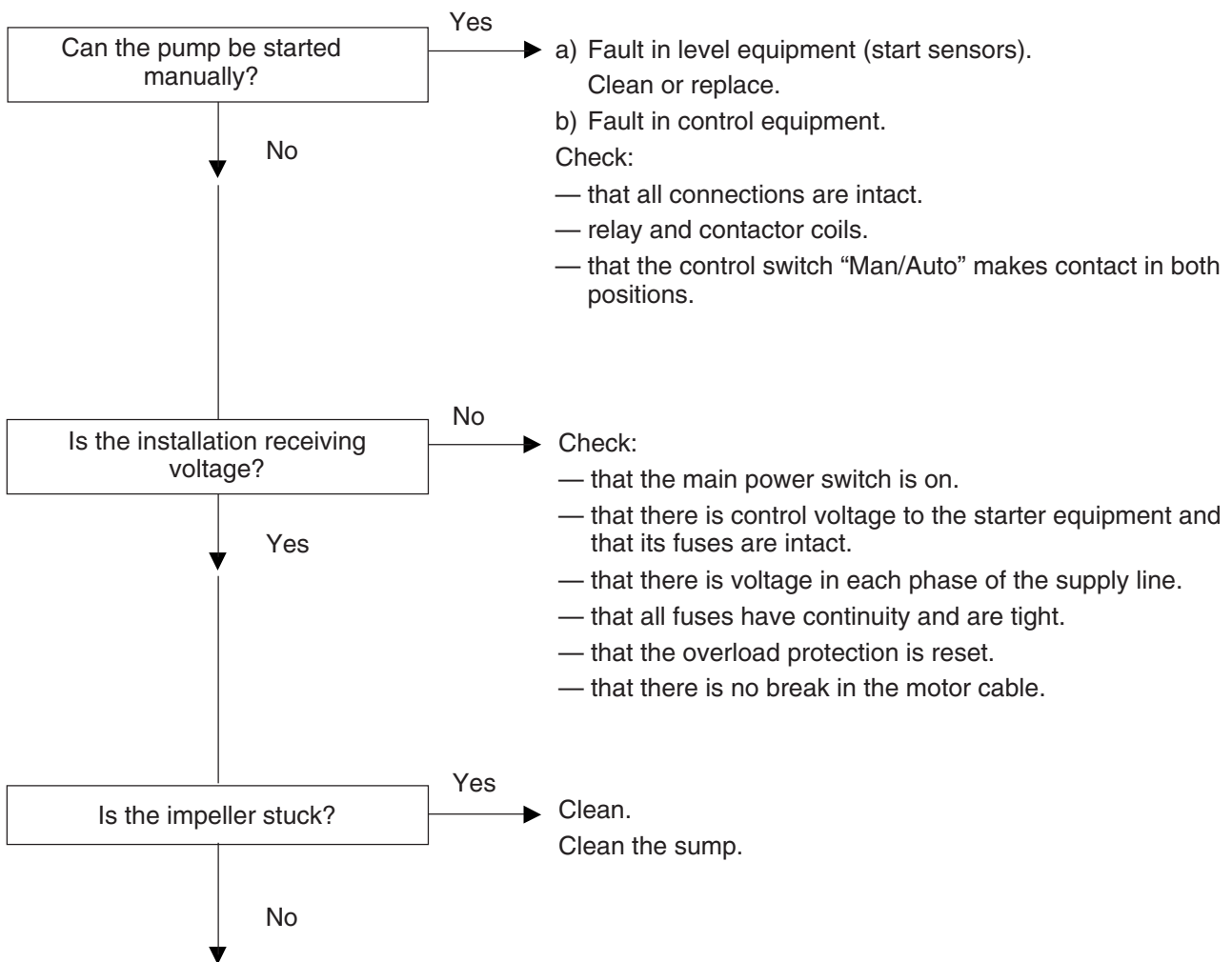

Contact Flygt service shop.



WARNING!
Disconnect power before checking the impeller.

2. Pump starts but motor protection trips

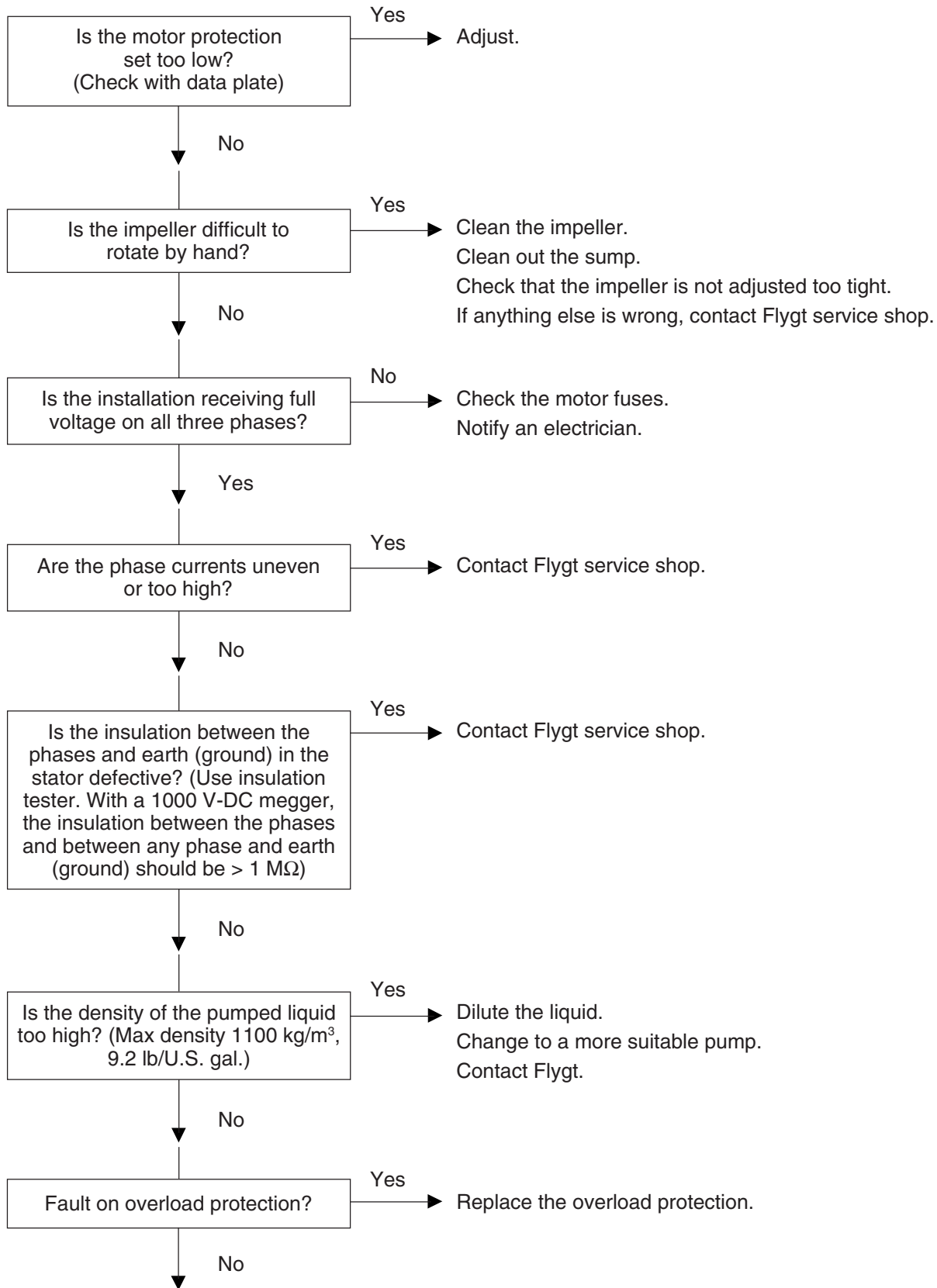

Contact Flygt service shop.

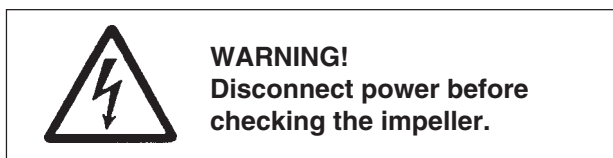

3. The pump does not stop

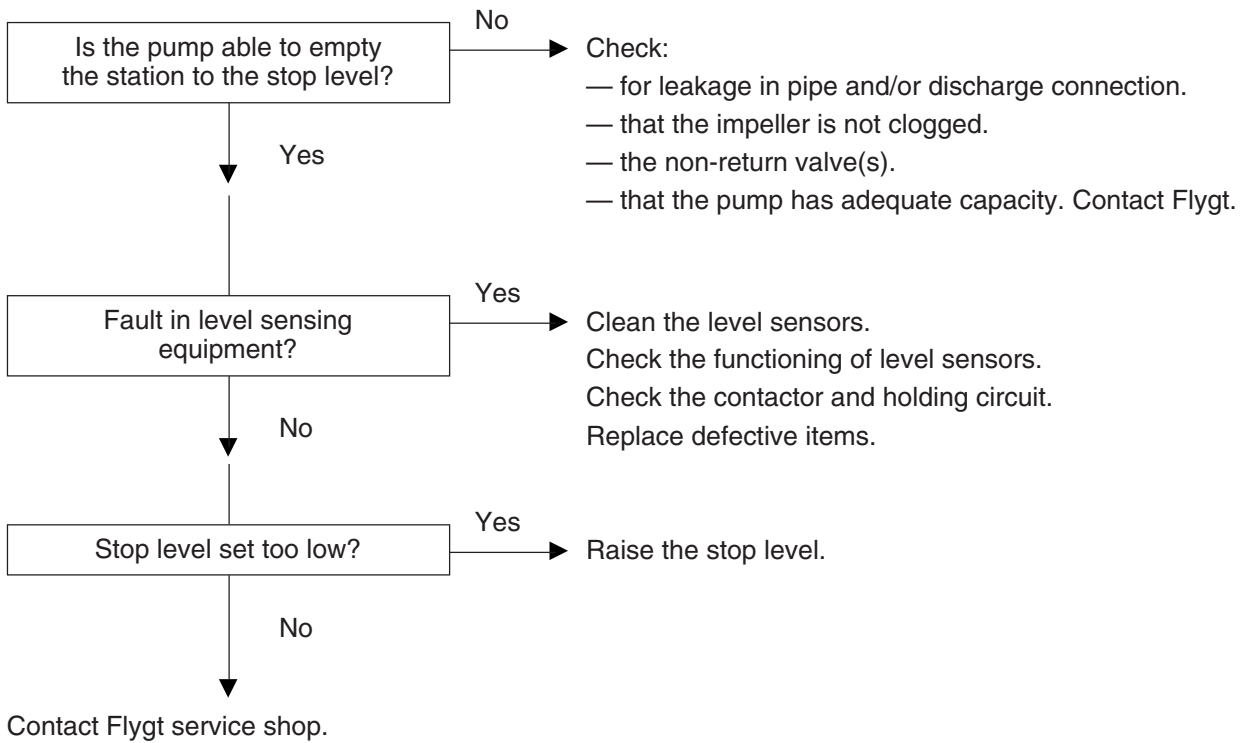

4. The pump starts-stops-starts in rapid sequence

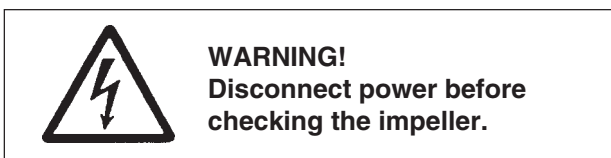
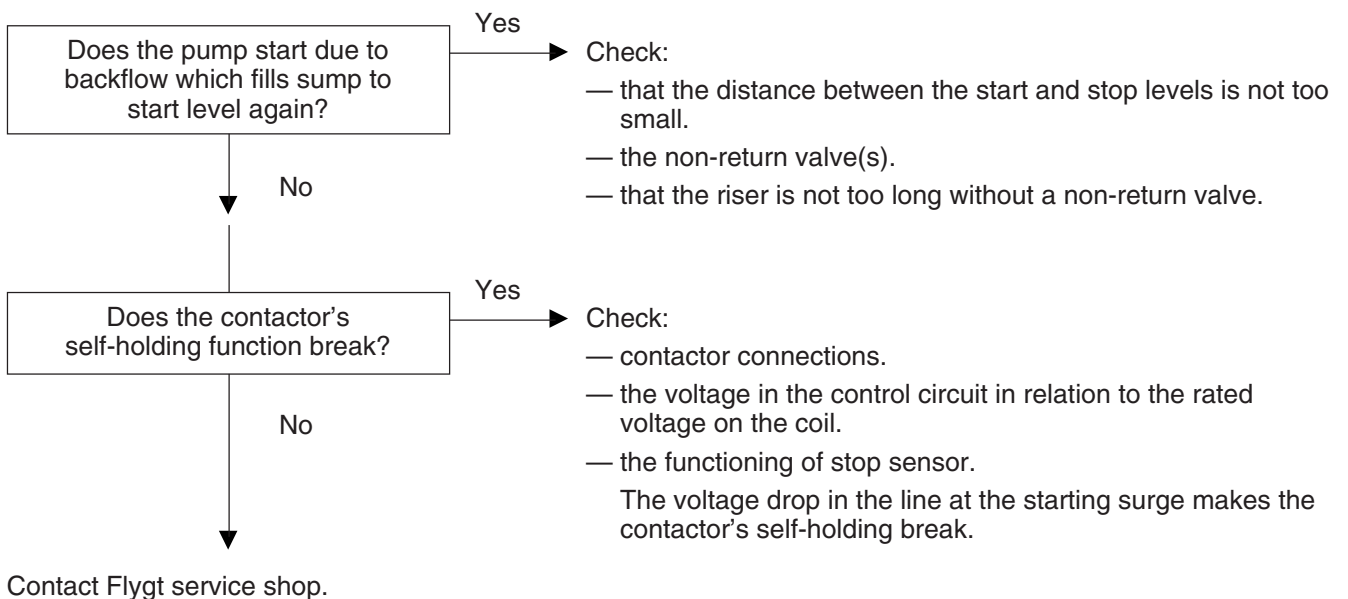

5. Pump runs but delivers too little or no water

Check:

- direction of rotation of the pump, see “Before starting”.
- that valves are open and intact.
- that pipes, impeller and strainer are not clogged.
- that the impeller rotates easily.
- that the suction lift has not been altered.
- for leakage in the pump installation.
- for wear on wear ring, impeller, pump casing/flange, suction bottom, diffuser disc, diffuser.

See also under “Inspection”.

Do not override the motor protection repeatedly if it has tripped.

SERVICE LOG

Most recent service date	Pump No.	Hours of operation	Remarks	Sign.

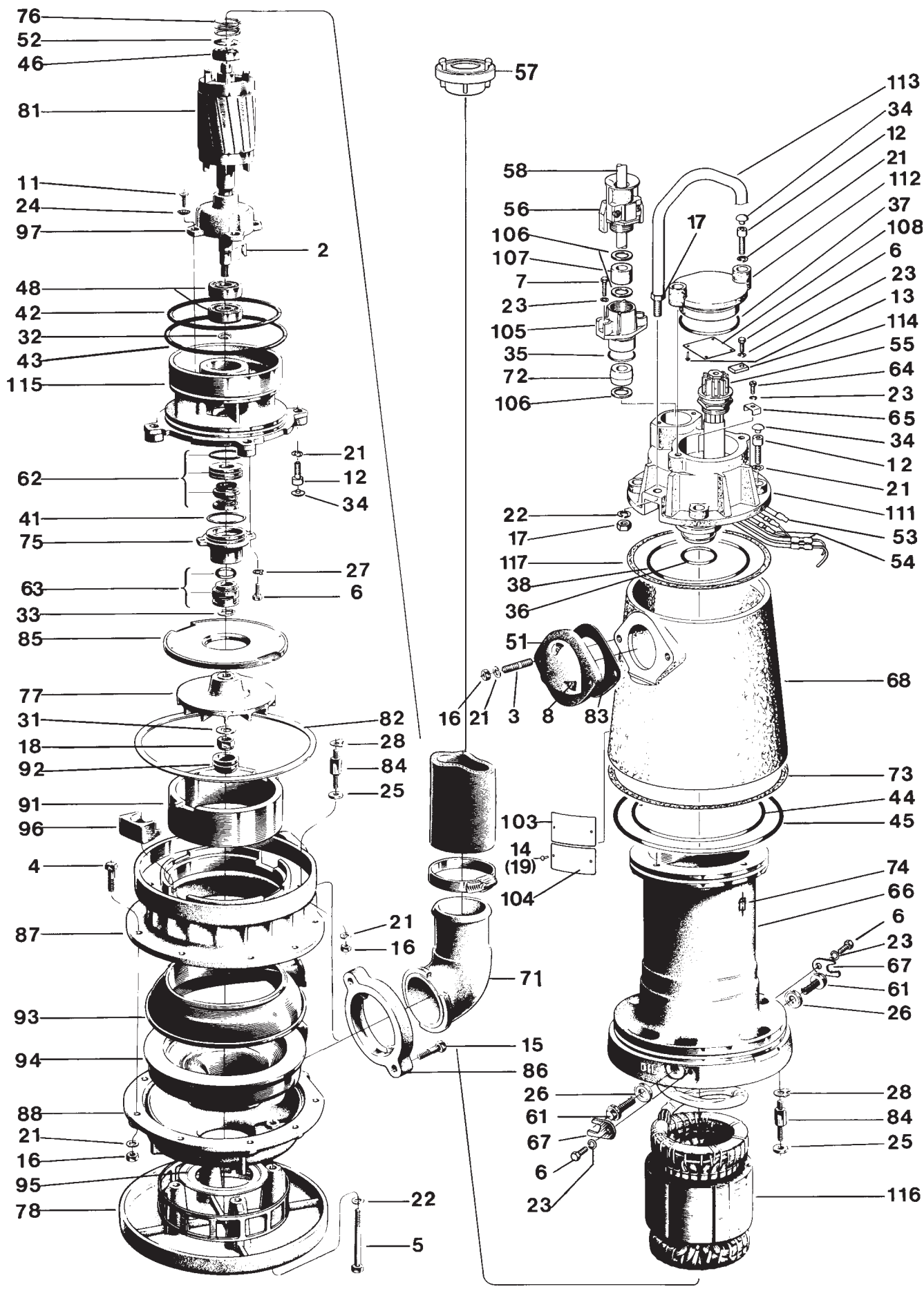



www.flygt.com