



Installation, Care and Maintenance

3045



CONTENTS

Safety _____	2	Cable chart _____	9
Data plate interpretation _____	3	Transportation and storage _____	12
Product description _____	4	Operation _____	12
General design of a Flygt pump _____	5	Care and maintenance _____	13
Installation _____	6	Oil change _____	14
Electrical connections _____	7	Hydraulic ends _____	15

SAFETY

This manual contains basic information on the installation, operating and maintenance and should be followed carefully. It is essential that these instructions are carefully read before installation or commissioning by both the installation crew as well as those responsible for operation or maintenance. The operating instructions should always be readily available at the location of the unit.

Identification of safety and warning symbols



General Danger:

Non-observance given to safety instructions in this manual, which could cause danger to life have been specifically highlighted with this general danger symbol.



High Voltage:

The presence of a dangerous voltage is identified with this safety symbol.

WARNING!

Non-observance to this warning could damage the unit or affect its function

Qualifications of personnel

An authorized (certified) electrician and mechanic shall carry out all work.

Safety regulations for the owner/operator

All government regulations, local health and safety codes shall be complied with.

All dangers due to electricity must be avoided (for details consult the regulations of your local electricity supply company).

Unilateral modification and spare parts manufacturing

Modifications or changes to the unit/installation should only be carried out after consulting with ITT Flygt.

Original spare parts and accessories authorized by the manufacturer are essential for compliance. The use of other parts can invalidate any claims for warranty or compensation.

Dismantling and re-assembly

If the pump has been used to pump hazardous media, care must be taken that, when draining the leakage, personnel and environment are not endangered.

All waste and emissions such as used coolant must be appropriately disposed of. Coolant spills must be cleaned up and emissions to the environment must be reported.

The pumping station must be kept tidy and in good order at all times.

All government regulations shall be observed.

The pictures in this manual may differ somewhat from the delivered pump depending on the hydraulic end configuration.

DATA PLATE INTERPRETATION

General data plate

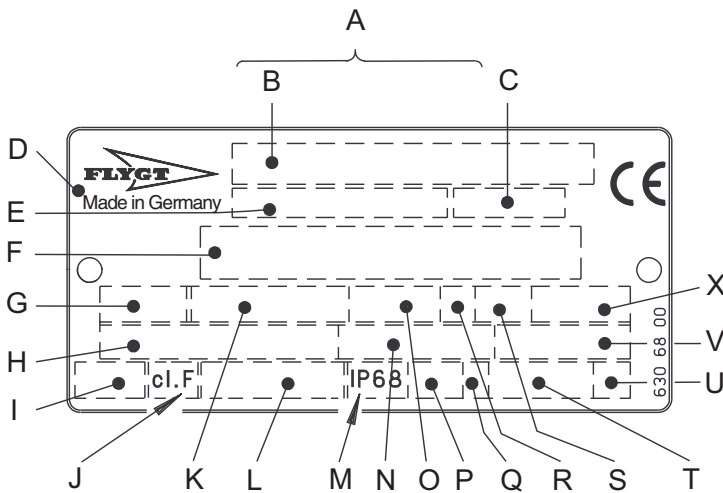

- A Serial number
- B Product code + Number
- C Curve code / Propeller code
- D Country of origin
- E Product number
- F Additional information
- G Phase; Type of current; Frequency
- H Rated voltage
- I Thermal protection
- J Thermal class
- K Rated shaft power
- L International standard
- M Degree of protection
- N Rated current
- O Rated speed
- P Max. submergence
- Q Direction of rotation: L=left, R=right
- R Duty class
- S Duty factor
- T Product weight
- U Locked rotor code letter
- V Power factor
- X Max. ambient temperature

Approval plates

These approval plates apply to an explosion-proof submersible Flygt pump. The plates are used together with the general data plate on the pump.

EN: European Norm
 ATEX Directive
 EN 50014, EN 50018, EN 1127-1 3045.090
 Ⓢ II 2 G EEx dII T4

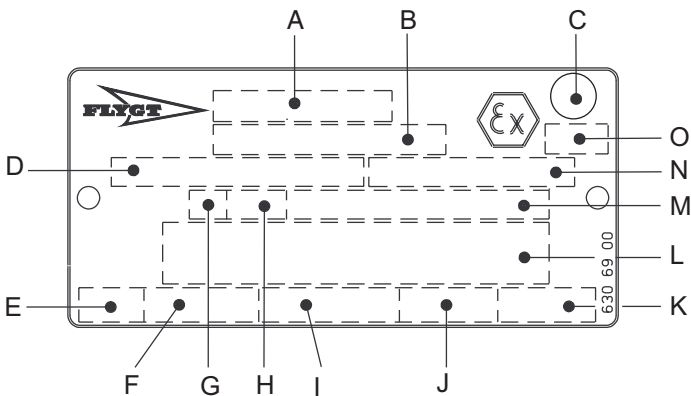

- A Approval
- B Approval authority + Approval Number
- C Approval for Class I
- D Approved drive unit
- E Stall time
- F Starting current; Rated current
- G Duty class
- H Duty factor
- I Input power
- J Rated speed
- K Controller
- L Additional information
- M Max. ambient temperature
- N Serial number
- O ATEX marking

FM: Factory Mutual
 Class I Div. I Grp C and D 3045.090
 Class II and III Div. I Grp E, F and G 3045.090

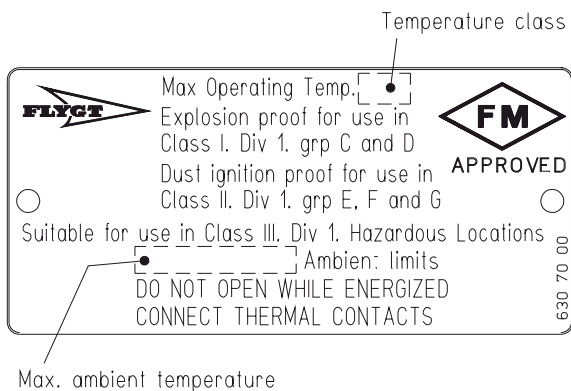

PRODUCT DESCRIPTION

Introduction

Thank you for buying a submersible Flygt pump. In this Installation, Care and Maintenance manual you will find general information on how to install and service the 3045 pump to give it a long and reliable life.

Application

This Installation, Care and Maintenance manual applies to a submersible Flygt pump. If you have bought an Ex-approved pump (please see approval plate on your pump) special handling instructions apply as described in this document.

Depending on the hydraulic end, the pump is intended to be used for:

- pumping of waste water,
- pumping of sludge,
- pumping of ground water.

The pumps must not be used in highly corrosive liquids. See pH limits below.

The pump is available for permanent installation in a sump or portable installation with hose connection and stand.

For further information on applications, contact your nearest Flygt representative.

Specific technical data

For specific technical data regarding your pump, please see the data plate.

General technical data

Liquid temperature: max. 40°C (104°F). The pump can be operated at full load only if at least half the stator housing is submerged.

The pump can be equipped for operation at temperatures up to 90°C (195°F). At increased temperatures, the pump must be completely submerged when operated at full load.

Higher temperatures than 40°C (104°F) are not permitted for 3045 or Ex-approved pumps.

Liquid density: max. 1100 kg/m³ (9.2 lb per US gal.)

The pH of the pumped liquid: 6—13 (cast iron pumps).

Depth of immersion: max. 20 m (65 ft).



- **In some installations and at certain operating points on the performance curve, the noise level of 70 dB or the noise level specified for the actual pump may be exceeded.**
- **Only Ex-approved pumps may be used in an explosive or flammable environment.**

Warranty claim

Flygt pumps are high quality products with expected reliable operation and long life. However, should the need arise for a warranty claim, please contact your Flygt representative.

GENERAL DESIGN OF A FLYGT PUMP

Design

The pump is a submersible, electric motor-driven product.

1. Impeller

The pump is available with a single channel or a vortex impeller.

2. Shaft seals

The pump has two mechanical face seals – one inner and one outer, with an intermediate oil housing.

3. Shaft

The shaft is delivered with the rotor as an integral part. Shaft material: stainless steel.

4. Bearings

The bearings of the shaft consist of single-row ball bearings.

5. Oil housing

The oil lubricates and cools the seals and acts as a buffer between the pump housing and the electric motor.

6. Motor

Squirrel-cage 1-phase or 3-phase induction motor for 50 Hz or 60 Hz.

The motor can be started by direct on-line or star-delta starting.

The motor can be run continuously or intermittently with a maximum of 15 evenly spaced starts per hour.

Flygt motors are tested in accordance with IEC 34-1.

The stator is insulated in accordance with class F (155°C, 310°F). The motor is designed to deliver its rated output at $\pm 5\%$ variation from the rated voltage. Without overheating the motor, $\pm 10\%$ variation from the rated voltage can be accepted provided that the motor does not run continuously at full load. The motor is designed to operate at a voltage imbalance of up to 2% between the phases.

Monitoring equipment

The stator incorporates thermal contacts connected in series for some versions.

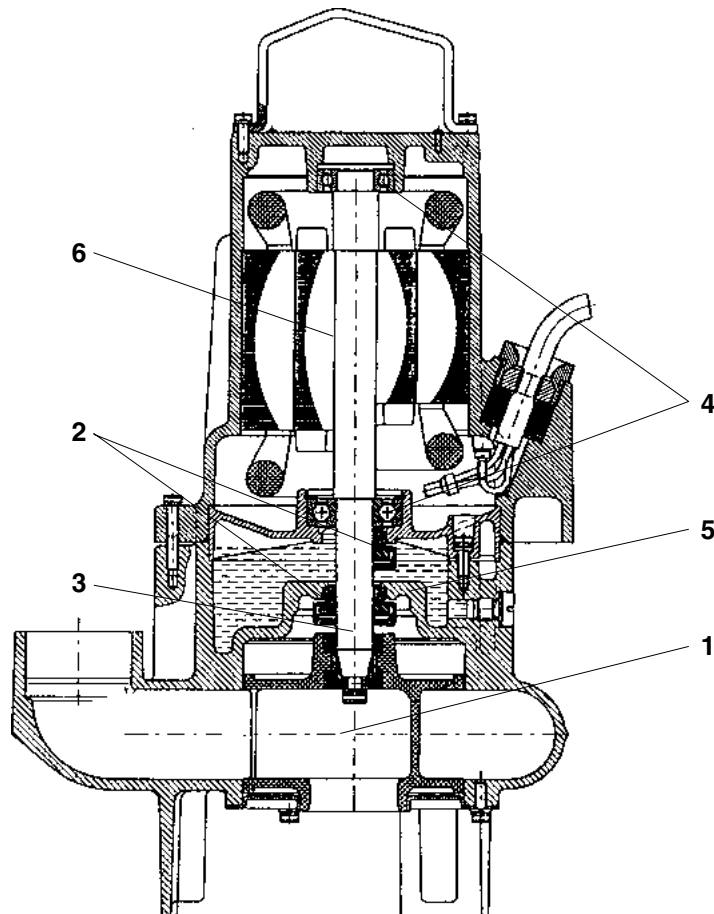

INSTALLATION

Handling equipment

Lifting equipment is required for handling the pump.



- **Stay clear of suspended loads.**
- **Always lift the pump by its lifting handle - never by the motor cable or the hose.**

The minimum height between the lifting hook and the floor shall be sufficient to lift the pump out of the sump.

The lifting equipment shall be able to hoist the pump straight up and down in the sump, preferably without the need for resetting the lifting hook.

Oversize lifting equipment could cause damage if the pump should stick when being lifted.

Make sure that the lifting equipment is securely anchored.

General recommendations

To ensure proper installation, please see the dimensions on the dimensional drawing in the Parts List.

NOTE! The end of the cable must not be submerged. It must be above flood level, as water may penetrate through the cable into the junction box or the motor.

Check that the lifting handle and chain are in good condition.

For automatic operation of the pump (level control), it is recommended that the level regulators be used at low voltage. The data sheet delivered with the regulators gives the permissible voltage. Local rules may specify otherwise.

Clean out all debris from the sump before the pump is lowered down and the station is started.



Special rules apply to installation in explosive atmosphere.

- **Intrinsically safe circuits are normally required (Ex i) for the automatic level control system by level regulators.**
- **Minimum stop level should be according to the dimensional drawing.**
- **The pump must never run dry or on snore.**

Safety precautions

In order to minimize the risk of accidents in connection with the service and installation work, the following rules should be followed:

1. Never work alone. Use a lifting harness, safety line and a respirator as required. Do not ignore the risk of drowning!
2. Make sure there are no poisonous gases within the work area.
3. Check the explosion risk before welding or using electric hand tools.
4. Do not ignore health hazards. Observe strict cleanliness.
5. Bear in mind the risk of electrical accidents.
6. Make sure that the lifting equipment is in good condition.
7. Provide a suitable barrier around the work area, e.g. a guard rail.
8. Make sure you have a clear path of retreat!
9. Use safety helmet, safety goggles and protective shoes.
10. All personnel who work with sewage systems must be vaccinated against diseases to which they may be exposed.
11. A first-aid kit must be close at hand.
12. Note that special rules apply to installation in explosive atmosphere.

Follow all other health and safety rules and local codes and ordinances.

ELECTRICAL CONNECTIONS



- Before starting work on the pump, make sure that the pump and the control panel are isolated from the power supply and cannot be energized.
- If the pump is equipped with automatic level control, there is a risk of sudden restart.
- All electrical equipment must be earthed. This applies to both pump equipment and any monitoring equipment. Failure to heed this warning may cause a lethal accident. Make sure that the earth lead is correctly connected by testing it.
- If persons are likely to come into physical contact with the pump or pumped media (liquid), e.g on construction sites and farms, the earthed (grounded) socket must have an additional earth-(ground-) fault protection device (GFI) connected.
When pumping near a lake (jetties, beaches, ponds, fountains etc) a safety-distance of at least 20 m (65 ft) between the person and the pump is applicable.
The pump must never be placed directly into a swimming pool. If used in connection with swimming pools, special safety regulations apply.



NOTE for Ex version

- Electrical connections on the explosion-proof motor must be made by authorized personnel.
Flygt disclaims all responsibility for work done by untrained, un-authorized personnel.
- The pump may be used only in accordance with the approved motor data stated on the data plates.
- Thermal contacts must be connected to protection circuit intended for that purpose according to the approval of the product.

All electrical work shall be carried out under the supervision of an authorized electrician.

Local codes and regulations shall be complied with.

Check on the data plate which voltage supply is valid for your pump.

Check that the main voltage and frequency agree with the specifications on the pump data plate.

If the pump can be connected to different voltages, the connected voltage is specified by a yellow sticker.

Connect the motor cable to the starter equipment as illustrated in the wiring diagrams.

Conductors that are not in use must be isolated.

The cable should be replaced if the outer sheath is damaged. Contact a Flygt service shop.

Make sure that the cable does not have any sharp bends and is not pinched.

Under no circumstances may the starter equipment be installed in the sump.

NOTE! For safety reasons, the earth conductor should be approx. 50 mm (2.0") longer than the phase conductors. If the motor cable is jerked loose by mistake, the earth conductor should be the last conductor to come loose from its terminal. This applies to both ends of the cable.

Thermal contacts are incorporated in the stator for some versions. The thermal contacts can be connected to max 250 V, breaking current max 4 A. Flygt recommends that they be connected to 24 V over separate fuses to protect the other automatic equipment.

Make sure that the pump is correctly earthed (grounded).

When using a variable-frequency-drive (VFD) the shielded cable (type NSSHÖU.../3E+St) should be used. Contact your Flygt representative and ask your VFD-supplier for electrical limitations.

ELECTRICAL CONNECTIONS

Remember that the starting current in direct on-line starting can be up to six times higher than the rated current. Make sure that the fuses or circuit breakers are of the proper rating.

The data plate gives rated current. Fuse rating and cable shall be selected in accordance with local rules and regulations. Note that with long cables, the voltage drop in the cable must be taken into consideration, since the motor's rated voltage is the voltage that is measured at the terminal board in the pump.

The overload protection (motor protection breaker) for direct on-line starting shall be set to the motor rated current as given on the data plate.

Check the phase sequence in the mains with the phase sequence indicator.

If intermittent operation is prescribed (see data plate), the pump shall be provided with control equipment that provides such operation.

Single phase operation

The Flygt single phase pumps must be equipped with a starter which has a capacitor.

A special Flygt designed starter is required for the operation of single phase pumps. The connection of the motor cable to the starter is shown in the wiring diagram.

NOTE! It is not possible to change the direction of rotation of a single phase pump by changing the cable conductors on the starter. Please contact your nearest Flygt representative.

CABLE CHART

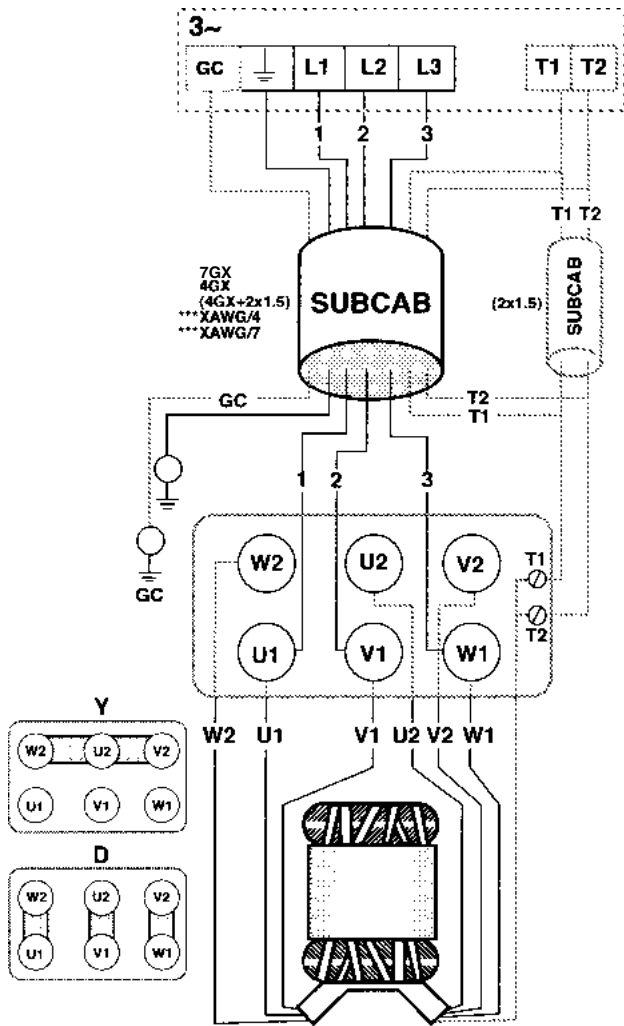

3-phase, direct on-line starting

	Conductors	Connection starter
SUBCAB 4Gx	1 brown ***red	L1
***SUBCAB xAWG/4	2 blue ***white	L2
H07RN-F 4Gx	3 black ***black	L3
BIHF 4Gx silicon	yellow/green	earth
SUBCAB 4Gx+2x1,5	1 brown	L1
	2 blue	L2
	3 black	L3
	yellow/green	earth
	T1 black	T1*
	T2 black	T2*
SUBCAB 7Gx	1 black	L1
H07RN-F 7Gx	2 black	L2
	3 black	L3
	4 black	cut off
	5 black	T1*
	6 black	T2*
	yellow/green	earth
For Canada/USA	red	L1
***SUBCAB xAWG/7	white	L2
	black	L3
	yellow	GC**
	yellow/green	earth
	orange	T1*
	blue	T2*
Stator leads	U1 = red	V2 = blue
	V1 = brown	W2 = black
	W1 = yellow	U2 = green

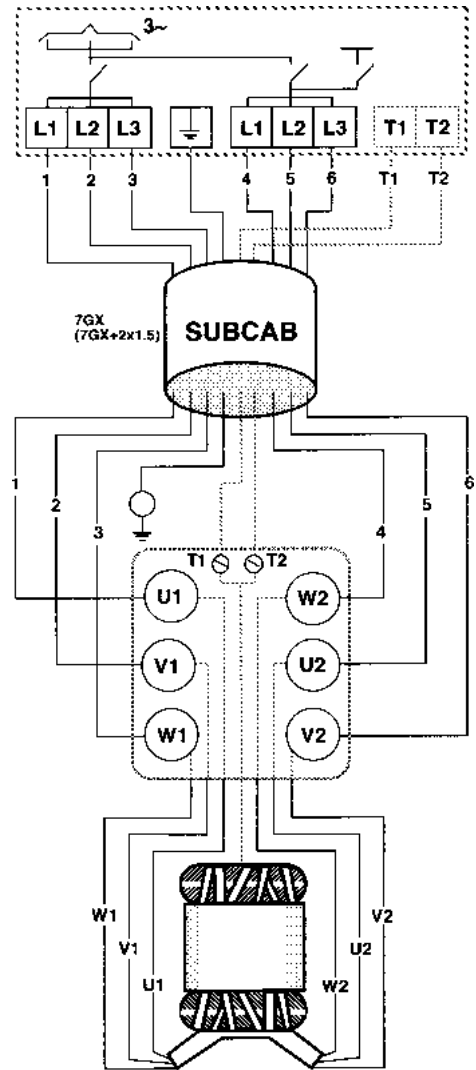

3-phase, star-delta starting

	Conductors	Connection starter
SUBCAB 7Gx	1 black	L1
	2 black	L2
	3 black	L3
	4 black	L1
	5 black	L2
	6 black	L3
	yellow/green	earth
SUBCAB 7Gx+2x1,5	1 black	L1
	2 black	L2
	3 black	L3
	4 black	L1
	5 black	L2
	6 black	L3
	T1 black	T1*
	T2 black	T2*
	yellow/green	earth
Stator leads	U1 = red	V2 = blue
	V1 = brown	W2 = black
	W1 = yellow	U2 = green

* Terminal for connection of thermal contacts in the motor and monitoring equipment.
 ** GC = Ground Check
 *** SUBCAB/AWG

SUBCAB is a registered trademark of ITT Flygt AB for electrical cables.

CABLE CHART

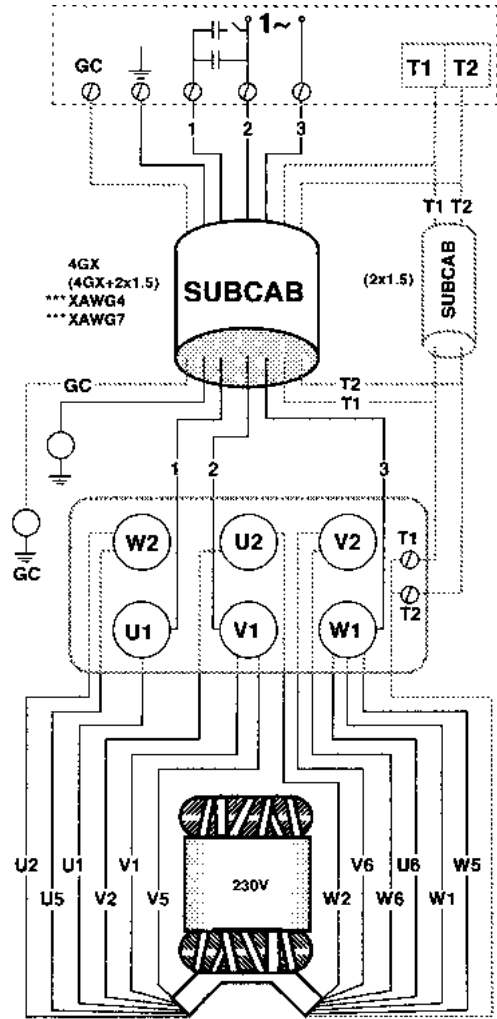
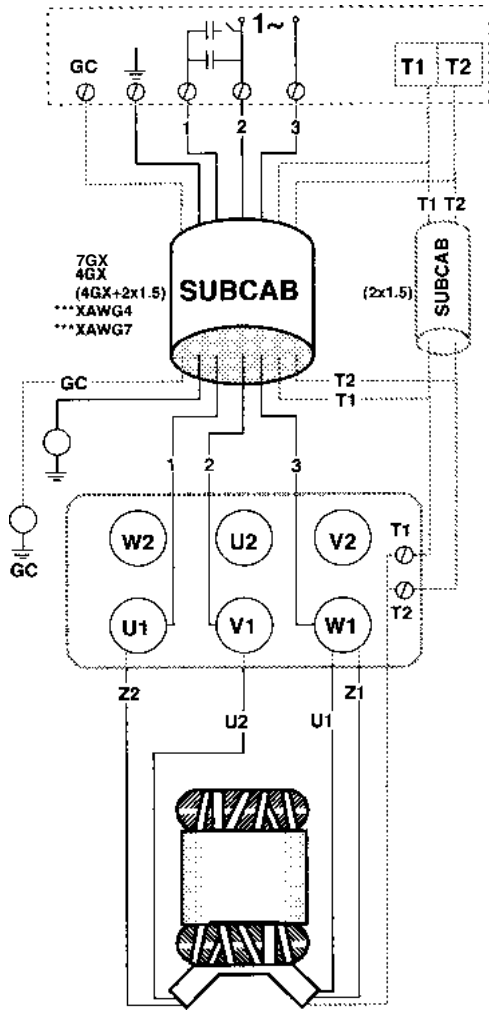

Single phase

	Conductors	Connection starter
SUBCAB 4Gx	1 brown ***red	1
***SUBCAB xAWG/4	2 black ***black	2
H07RN-F 4Gx	3 blue ***white	3
BIHF 4Gx silicon	yellow/green	earth
SUBCAB 4Gx+2x1,5	1 brown	1
	2 black	2
	3 blue	3
	yellow/green	earth
	T1 black	T1*
	T2 black	T2*
SUBCAB 7Gx	1 black	1
	2 black	2
	3 black	3
	4 black	cut off
	5 black	T1*
	6 black	T2*
	yellow/green	earth
For Canada/USA	red	1
***SUBCAB xAWG/7	black	2
	white	3
	yellow	GC**
	yellow/green	earth
	orange	T1*
	blue	T2*

Stator leads

U1 = red	U2 = brown
Z1 = yellow	Z2 = black

Stator leads

U1 = red	U5 = red
V1 = brown	V5 = brown
W1 = yellow	W5 = yellow
U2 = green	U6 = green
V2 = blue	V6 = blue
W2 = black	W6 = black

* Terminal for connection of thermal contacts in the motor and monitoring equipment.

** GC = Ground Check

*** SUBCAB/AWG

CABLE CHART

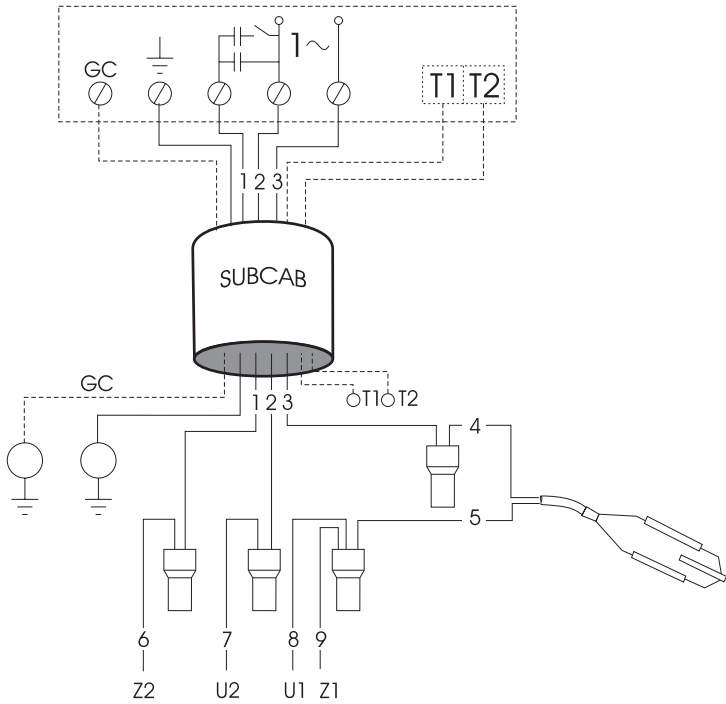

Single phase with level regulator

	Conductors	Connection starter
Motor cable		
Conductor identification	See specification single phase above	
Level regulator	brown	4
	blue	5
Stator leads	Z2, black	6
	U2, brown	7
	U1, red	8
	Z1, yellow	9

TRANSPORTATION AND STORAGE

The pump can be transported and stored in a vertical or horizontal position.



- **Always lift the pump by its lifting handle – never by the motor cable or the hose.**
- **Make sure that the pump cannot roll or fall over and injure people or damage property.**

The pump is frostproof as long as it is operating or is immersed in the liquid. If the pump is raised when the temperature is below freezing, the impeller may freeze.

The pump shall be run for a short period after being raised in order to discharge all remaining water.

A frozen impeller can be thawed by allowing the pump to stand immersed in the liquid for a short period before it is started. Never use a naked flame to thaw the pump.

For longer periods of storage, the pump must be protected against moisture and heat. The impeller should be rotated occasionally (for example every other month) to prevent the seals from sticking together.

After a long period of storage, the pump should be inspected before it is taken into operation. Pay special attention to the seals and the cable entry.

Follow the instructions under the heading “Before starting”.

OPERATION

Before starting



- **Before starting work on the pump, make sure that the pump is isolated from the power supply and cannot be energized.**
- **Make sure that the pump cannot roll or fall over and injure people or damage property.**

Check that the visible parts on the pump and installation are undamaged and in good condition.

Check the oil level in the oil housing.

Remove the fuses or open the circuit breaker and check that the impeller can be rotated freely.

Check that the monitoring equipment (if any) works.

Check the direction of rotation. The impeller shall rotate clockwise, as viewed from above. When started, the pump will jerk in the opposite direction to the direction in which the impeller rotates. See the figure.

Transpose two phase leads if the impeller rotates in the wrong direction (3 ~).



In some installations the pump surface and the surrounding liquid may be hot. Bear in mind the risk of burn injuries.

Starting jerk

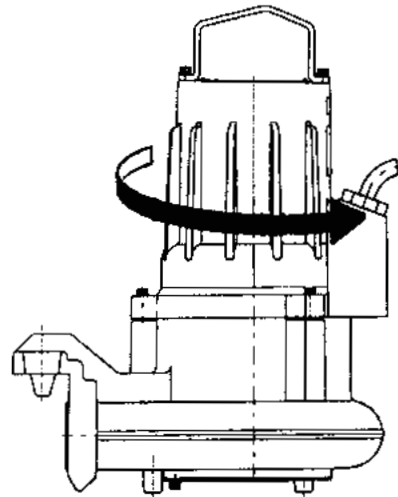

Watch out for the starting jerk, which can be powerful.

CARE AND MAINTENANCE



Before starting work on the pump, make sure that the pump is isolated from the power supply and cannot be energized.

This applies to the control circuit as well.



NOTE for Ex version

All work on the explosion-proof motor section must be performed by personnel authorized by Flygt.

Flygt disclaims all responsibility for work done by untrained, unauthorized personnel.



Make sure that the pump cannot roll or fall over and injure people or damage property.

The following points are important in connection with work on the pump:

- Make sure that the pump has been thoroughly cleaned.
- Beware of the risk of infection.
- Follow local safety regulations.

The pump is designed for use in liquids which can be hazardous to health. In order to prevent injury to the eyes and skin, observe the following points when working on the pump:

- Always wear goggles and rubber gloves.
- Rinse the pump thoroughly with clean water before starting work.
- Rinse the components in water after dismantling.
- The oil housing may be under pressure. Hold a rag over the oil screw (oil plug) to prevent splatter.

Proceed as follows if hazardous chemicals have splashed into your eyes:

- Rinse your eyes immediately in running water for 15 minutes. Hold your eyelids apart with your fingers.
- Contact an eye specialist.

On your skin:

- Remove contaminated clothes.
- Wash your skin with soap and water.
- Seek medical attention, if required.

Inspection

Regular inspection and preventive maintenance ensure more reliable operation.

The pump should be inspected at least once a year, but more frequently under severe operating conditions.

Under normal operating conditions, the pump should have a major overhaul in a service shop at least every third year for permanent installation and every year for portable pumps. This requires special tools and should be done by an authorized service shop.

If the seals have been replaced an inspection of the oil is recommended after one week of operation.

NOTE! Regular check of the condition of the lifting handle and chain is important.

Inspection of hot water applications

Pumps in hot water applications shall undergo inspection or overhaul at a service shop as follows, depending on the time they have been submerged in the hot water:

Temp.	Mode of operation	Inspection	Shop overhaul
≤70°C (160°F)	Continuous	1000 hours	4000 hours
≤70°C (160°F)	Intermittent	twice a year	once a year
≤90°C (195°F)	Cont./Int.	6 times a year	twice a year

OIL CHANGE

A check of the condition of the oil can show whether there has been leakage. Note! Air/oil mixture can be confused with water/oil mixture.

Insert a tube (or hose) into the oil hole. Cover the top end of the tube and take up a little oil from the bottom.

Change the oil if it contains too much water, i.e. if it is heavily emulsified (cream-like), or if the oil housing contains free water. Check again one week after changing the oil.



The oil housing may be under pressure. Hold a rag over the oil plug to prevent splatter.

1. Lay the pump on its side on a bench or over two supports. Unscrew the oil housing screw (oil plug) and drain the oil.

2. Fill with new oil.

A paraffin oil with viscosity close to ISO VG15 is recommended (e.g. Mobil Whiterex 309). The pump is delivered from factory with this type of oil.

In applications where poisonous properties are of less concern, a mineral oil with viscosity up to ISO VG32 can be used.

3. Replace the O-rings under the oil housing screws (plugs) with new ones.



HYDRAULIC ENDS

3045

C

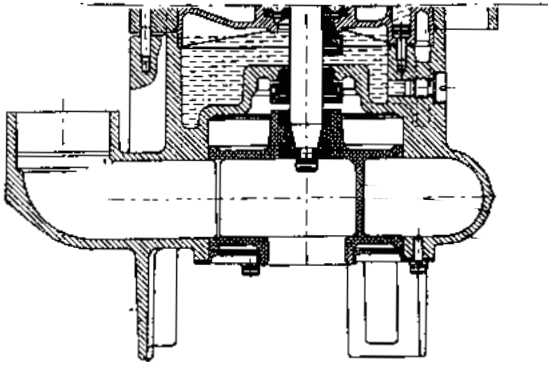

D

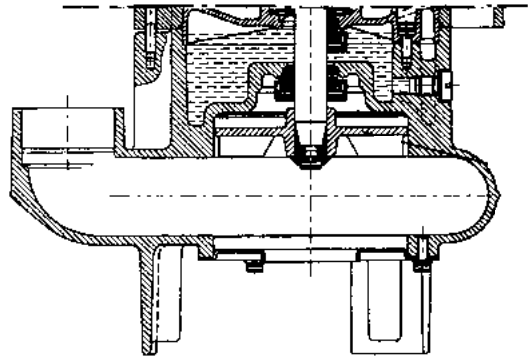



www.flygt.com