

Stainless steel

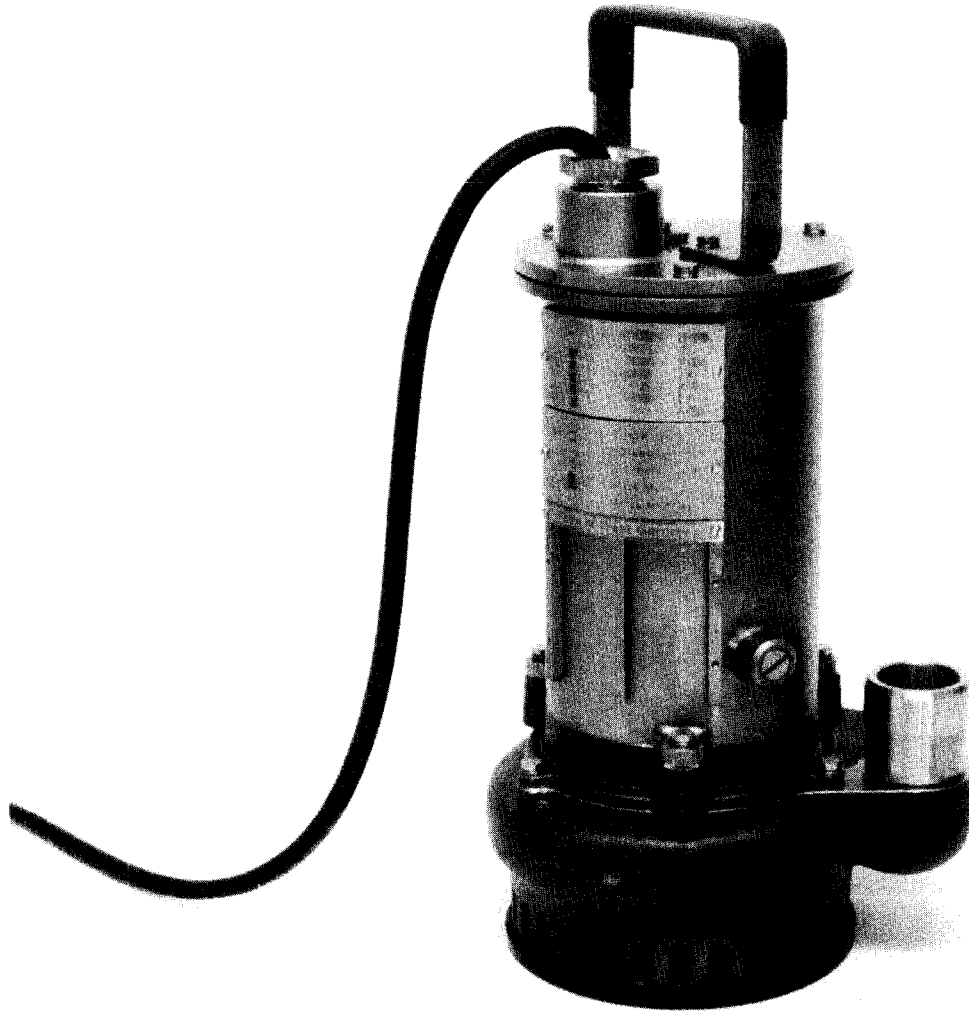

CARE AND MAINTENANCE



890308/05

DATA PLATE INTERPRETATION

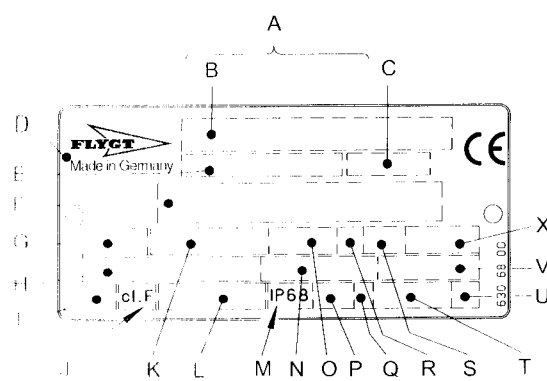

A	Serial number
B	Product code + Number
C	Curve code / Propeller code
D	Country of origin
E	Product number
F	Additional information
G	Phase; Type of current; Frequency
H	Rated voltage
I	Thermal protection
J	Thermal class
K	Rated shaft power
L	International standard
M	Degree of protection
N	Rated current
O	Rated speed
P	Max. submergence
Q	Direction of rotation: L=left, R=right
R	Duty class
S	Duty factor
T	Product weight
U	Locked rotor code letter
V	Power factor
X	Max. ambient temperature

Flygt undertakes to remedy faults in products sold by Flygt provided:

- that the fault is due to defects in design, materials or workmanship;
- that the fault is reported to Flygt or Flygt's representative during the guarantee period;
- that the product is used only under conditions described in the care and maintenance instructions and in applications for which it is intended;
- that the monitoring equipment incorporated in the product is correctly connected;
- that all service and repair work is done by a workshop authorized by Flygt;
- that genuine Flygt parts are used.

Hence, the guarantee does not cover faults caused by deficient maintenance, improper installation, incorrectly executed repair work or normal wear and tear.

Flygt assumes no liability for either bodily injuries, material damages or economic losses beyond what is stated above.

Flygt guarantees that a spare parts stock will be kept for 15 years after the manufacture of this product has been discontinued.

The manufacturer reserves the right to alter performance, specification or design without notice.

CONTENTS

Product description	2
Applications	2
Design	2
Dimensions and weights	4
Transportation and storage	5
Installation	5
Safety precautions	5
Handling equipment	5
Installation alternatives	6
Electrical connections	7
Before starting	8
Care and maintenance	9
Safety precautions	9
Inspection	9
Changing the oil	15
Replacing the impeller	16
Accessories and tools	18
Fault tracing (Troubleshooting)	19
Service log	23

PRODUCT DESCRIPTION

Applications

3041 is intended to be used for:
pumping of water which may contain abrasive particles
pumping of corrosive liquids, see specification.

The pump is available in the following versions:

Liquid temperature: max. 40°C (105°F)

The pump is also available in a version for liquid temperatures up to 90°C (195°F). This version has certain operational limitations which are stated on a plate on these pumps.

Liquid density: max. 1100 kg/m³ (9.2 lb per US gal.)

The pumped liquid may contain particles up to a size which corresponds to the throughlet of the pump.

The pH of the pumped liquid: 3—14

Lowest liquid level: half-way the stator casing.

Depth of immersion: max. 20 m (66 ft).

The pump shall not be used in explosive or flammable environments or with flammable liquids.

For other applications, contact your nearest Flygt representative for information.

Design

3041 is a submersible, electric motor-driven pump.

Impellers

The pump is available with the following types of impellers:
multi-vane impeller of stainless steel.

Shaft seals

The pump has two mechanical seals.

Materials:

Inner seal: carbon — ceramic.

Outer seal: silicon carbide/
silicon carbide or ceramic/ceramic

Shaft

The shaft is delivered with the rotor as an integral part.

The shaft is completely sealed and will not come into contact with the pumped liquid.

Shaft material: stainless

Bearings

The pump bearings are designed for at least 10 000 hours of operation.

The lower and upper bearing consists of a single row ball bearing type.

Oil casing

The oil lubricates and cools the seals and acts as a buffer between the pump casing and the electric motor.

Pressure build-up within the oil casing is reduced by means of a built-in air volume.

PERFORMANCE CURVES

(40°C/105°F)

Each pump is tested in accordance with ISO 2548 Class C.

□ = Optimum operating point

50 Hz 3 ~

Input kW

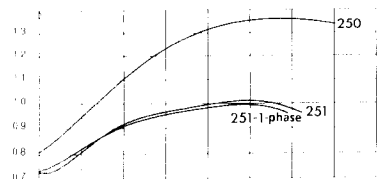

Head m

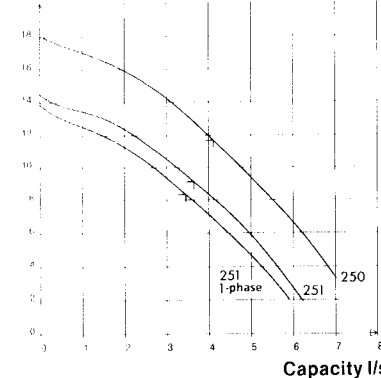

60 Hz 3 ~

Input kW

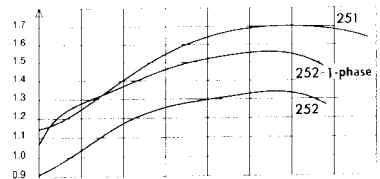

Head m

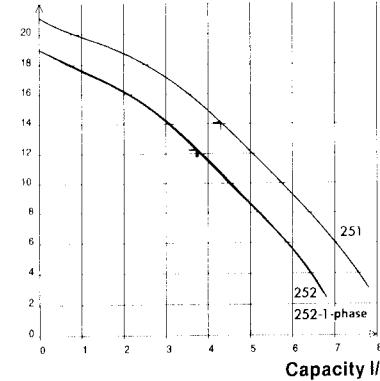

50 Hz

Rated output kW	Phase	Speed r/min	Rated current			
			220V	380V	440V	550V
1.1	3	2815	4.0A	2.3A	2.0A	1.6A
1.0	1	2850	110V	120V	220V	240V
			13A	12A	6.5A	6.0A

60 Hz

Rated output kW	Phase	Speed r/min	Rated current			
			220V	230V	460V	575V
1.4	3	3395	5.1A	4.9A	2.4A	1.9A
1.2	1	3450	110V	115V	220V	230V
			15A	14A	7.4A	7.1A

Motor

Squirrel-cage 1-phase or 3-phase induction motor for 50 Hz or 60 Hz.

The motor is started by means of:

continuously or intermittently with a maximum of 15 evenly spaced starts per hour.

The stator is insulated in accordance with class F (155°C, 310°F). The motor is designed to supply its rated output at $\pm 5\%$ variation of the rated voltage. Without overheating the motor, $\pm 10\%$ variation of the rated voltage can be accepted provided that the motor does not run continuously at full load. The motor is designed to operate with a voltage imbalance of up to 2% between the phases.

Monitoring equipment

The stator incorporates two thermal switches connected in series.

The thermal protectors:

open at 140°C (285°F).

The thermal switches of the warm liquid version shall not be connected when the liquid temperature is above 40°C (104°F).

Cooling

The stator is cooled by the surrounding liquid.

DIMENSION IN MM

Technical data

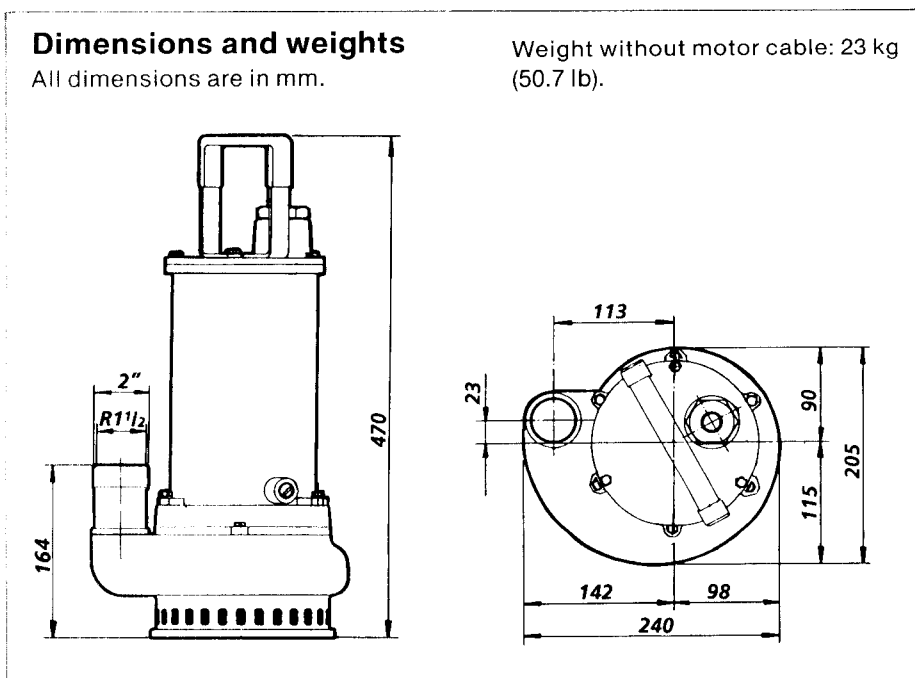

TRANSPORTATION AND STORAGE

The pump shall be transported and stored in a vertical position. Make sure that it cannot fall over.

Always lift the pump by its carrying handle or lifting eyes, **never** by the motor cable or the hose.

The pump is frostproof as long as it is operating or is immersed in the liquid. If the pump is taken up when the temperature is below freezing, the impeller may freeze. The pump shall be operated for a short period after being taken up in order to expel all remaining water.

A frozen impeller can be thawed by allowing the pump to stand immersed in the liquid for a short period before it is started. Never use an open flame to thaw the pump.

For longer periods of storage, the pump must be protected against moisture and heat. The impeller should be rotated by hand occasionally (for example every other month) to prevent the seals from sticking together. If the pump is stored for more than 6 months, this rotation is mandatory.

After a long period of storage, the pump should be inspected before it is put into operation. Pay special attention to the seals and the cable entry.

During a longer period out of operation, the pump shall be test-started every other month to prevent the mechanical seals from sticking together.

NOTE! The pump may not run idle longer than 30 seconds.

INSTALLATION

Safety precautions

In order to minimize the risk of accidents in connection with the service and installation work, the following rules should be followed:

1. Never work alone. Use a lifting harness (part No. 84 33 02), safety line (part No. 84 33 03) and a respirator (part No. 84 33 01), as required. Do not ignore the risk of drowning!
2. Make sure that there is sufficient oxygen and that there are no poisonous gases present.
3. Check the explosion risk before welding or using electric hand tools.
4. Do not ignore health hazards. Observe strict cleanliness.
5. Bear in mind the risk of electrical accidents.
6. Make sure that the lifting equipment is in good condition.
7. Provide a suitable barrier around the work area, for example a guard rail.
8. Make sure you have a clear path of retreat!
9. Use safety helmet, safety goggles and protective shoes.
10. All personnel who work with sewage systems shall be vaccinated against diseases that can occur.
11. A first-aid kit must be handy.

Follow all other health and safety rules and local codes and ordinances.

Handling equipment

Lifting equipment will facilitate handling of the pump.

WARNING! Keep out from under suspended loads.

Installation alternatives

CS version

In the CS version, the pump is transportable and intended to operate completely or partially submerged in the pumped liquid.

The pump is equipped with a connection for hose or pipe, see "Parts list".

The pump stands on a strainer with a support plate.

CS installation

Run the cables so that they have no sharp bends, are not pinched and cannot be sucked into the pump inlet. Connect the discharge line and the motor cable. See "Electrical connections".

Lower the pump into the sump.

Place the pump on a base which prevents it from sinking into a soft sump bottom.

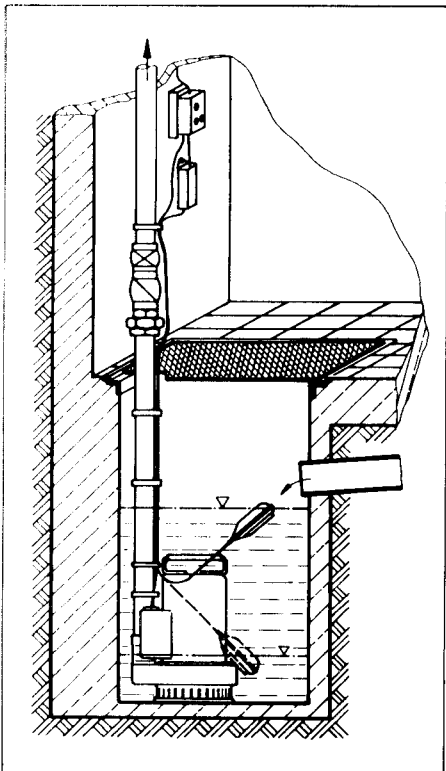

6

Alternatively, the pump can be suspended from above by its handle just above the bottom of the sump.

CF version

In the CF version, the pump stands on the bottom of the sump and is held in place by the discharge pipe. It operates completely or partially submerged in the liquid.

CF installation

Run the cables so that they do not have any sharp bends and are not pinched.

NOTE! The end of the cable must not be submerged. Leads have to be above flood level, as water may penetrate through the cable into the junction box or the motor.

Clean out debris from the sump.

Protect bolts and nuts with corrosion-preventive compound.

Connect the discharge line and motor cable. See "Electrical connections".

Lower the pump into the sump.

Pump installation

Run the cables so that they do not have any sharp bends and are not pinched.

Connect the discharge connection and motor cable. See "Electrical connections".

Lower the pump into the sump.

Place the pump on a base which will prevent it from sinking into a soft sump bottom. Alternatively, the pump can be suspended by its handle just above the sump bottom.

Consult your nearest Flygt representative regarding:

- sizing of sump, pumping station and access frame.
- choice of peripheral equipment.
- other problems in connection with installation.

Electrical connections

All electrical work shall be carried out under the supervision of an authorized electrician.

Local codes and regulations shall be complied with.

Check that the main voltage and frequency agree with the specifications on the pump data plate.

The motor can be connected for different voltages as shown on the data plate.

If intermittent operation is prescribed (see Data Plate), the pump shall be provided with a control equipment that provides such operation.

Under no circumstances may the starter equipment be installed in the pump pit.

Install the motor cable and the control cable as illustrated in the figure.

To avoid leakage into the pump, check:

- that the cable entry seal sleeve and washers conform to the outside diameter of the cable. See the parts list.
- that the outer jacket on the cable is not damaged. When refitting a cable which has been used before, **always** cut off a short piece of the cable so that the cable entry seal sleeve does not close around the cable at the same point again.

NOTE! For safety reasons, the earth lead should be approx. 40 mm (1 1/2") longer than the phase leads. If the motor cable is jerked loose by mistake, the earth lead should be the last lead to come loose from its terminal. This applies to both ends of the cable.

1-phase operation

The stator leads are connected to the terminal board as illustrated in the figure.

U1	Red
U2	Brown
U5	Yellow
U6	Green
Z1	Blue
Z2	Black
Z5	Red
Z6	Brown

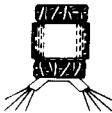

Connect the motor cable to the terminal board as follows. Mount the closing links as illustrated.

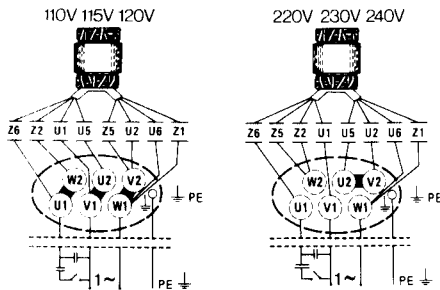

3-phase operation

The stator leads are connected to the terminal board as illustrated in the figure.

U1	Red
V1	Brown
W1	Yellow
U2	Green
V2	Blue
W2	Black
U5	Red
V5	Brown
W5	Yellow



6-lead stator

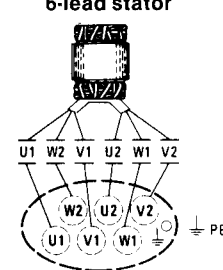

Connect the motor cable to the terminal board as follows. Mount the closing links as illustrated.

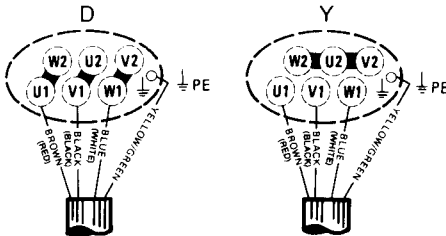

9-lead stator

Connect the motor cable to the terminal board as follows. Mount the closing links as illustrated.

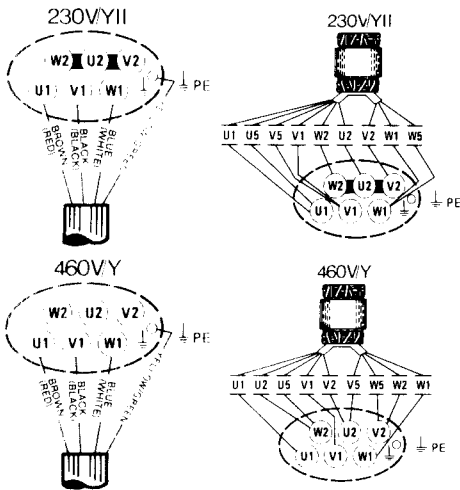

Connect the motor cable with the stator leads. See page 7.

Make sure that the pump is correctly earthed (grounded).

Tighten the gland nut (78) so that the cable entry unit bottoms out.

Connect the motor cable and the control cable to the starter equipment. Check the direction of rotation, see "Before starting".

If the direction of rotation is wrong, transpose two of the phase leads.

For 1-phase pumps going in wrong direction, please contact your nearest Flygt representative.

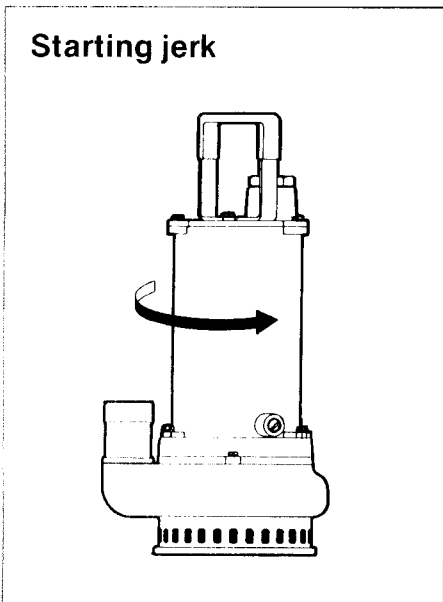

Before starting

Check the oil level in the oil casing.

Remove the fuses or open the circuit breaker and check that the impeller can be rotated by hand.

Check that the monitoring equipment (if any) works.

Check the direction of rotation. See the figure. The impeller shall rotate clockwise, as viewed from above. When started, the pump will jerk in the opposite direction to the direction in which the impeller rotates.

WARNING! Watch out for the starting jerk, which can be powerful.

CARE AND MAINTENANCE

The figures in parentheses are item numbers and refer to the cutaway figure.

Safety precautions

Before starting work on the pump, make sure that the pump is isolated from the power supply and cannot be energized.

NOTE! This applies to the control circuit as well.

The following points are important in connection with work on the pump:

- make sure that the pump has been thoroughly cleaned.
- observe good personal hygiene.
- beware the risk of infection.
- follow local safety regulations.

The pump is designed for use in liquids which can be hazardous to health. In order to prevent injury to the eyes and skin, observe the following points when working on the pump:

- Always wear goggles and rubber gloves.
- Rinse the pump thoroughly with clean water before starting work.
- Rinse the components in water after disassembly.
- Hold a rag over the oil casing screw (31) and the inspection screw (31) when removing them. Otherwise, pressure that may have built up in the pump due to the leakage of pumped liquid into the pump may cause splatter into the eyes or onto skin.

Proceed as follows if you get hazardous chemicals

in your eyes:

- rinse immediately in running water for 15 minutes. Hold your eyelids apart with your fingers.
- contact an eye doctor.

on your skin:

- remove contaminated clothes.
- wash skin with soap and water.
- seek medical attention if required.

Inspection

Regular inspection and preventive maintenance ensure more reliable operation.

The pump should be inspected at least once a year, more frequently under severe operating conditions.

Under normal operating conditions, the pump should have a major overhaul in a service shop every third year.

This requires special tools and should be done by an authorized service shop.

When the pump is new or when the seals have been replaced, inspection is recommended after one week of operation.

Service contract

Flygt or its agent offers service agreements in accordance with a preventive maintenance plan. For further information, please contact your Flygt representative.

Recommended inspections

Inspection of	Action
Visible parts on pump and installation	<p>Replace or fix worn and damaged parts.</p> <p>Make sure that all screws, bolts and nuts are tight.</p> <p>Check the condition of carrying handle/lifting eyes, chains and wire ropes.</p> <p>Check that the guide bars are vertical.</p>
Pump casing and impeller	<p>Replace worn parts if they impair function.</p> <p>Wear on the outlet flange on the pump casing usually causes corresponding wear on the discharge connection.</p> <p>Wear on the impeller and the parts around it necessitates fine adjustment of the impeller or replacement of worn parts. See "Replacing the impeller" and "Replacing the diffuser".</p>
Oil quantity	<p>WARNING. If the seal leaks, the oil casing may be under pressure. Hold a rag over the oil casing screw in order to prevent splatter. See "Safety precautions" for additional information.</p>
Condition of the oil	<p>A check of the condition of the oil can show whether there has been an increased leakage. Note! Air/oil mixture can be confused with water/oil mixture.</p> <p>Insert a tube (or hose) into the oil hole. Cover the top end of the tube and take up a little oil from the bottom.</p> <p>Change the oil if it contains too much water, i.e., is heavily emulsified (cream-like), or if the oil housing contains separated water. See "Changing the oil". Check again one week after changing the oil.</p> <p>If the oil contains too much water again, the fault may be:</p> <ul style="list-style-type: none">— that an oil screw (31) is not sufficiently tight.— that the O-ring (21) of an oil screw or its sealing surface is damaged.— that the lower mechanical seal (50) is damaged. Contact a Flygt service shop.

Inspection of	Action
Liquid in the stator casing	<p>WARNING. If there has been leakage, the stator casing may be under pressure. Hold a rag over the inspection screw to prevent splatter. See "Safety precautions" for additional information.</p> <p>Turn the pump so the inspection hole faces downward.</p> <p>Tilt the pump so that any liquid in the stator casing can run out through the hole.</p> <p>If there is water in the stator casing, the cause may be:</p> <ul style="list-style-type: none"> — that the inspection screw (31) is not sufficiently tight. — that the O-ring (21) of the inspection screw or its sealing surface is damaged. — that an O-ring (23) is damaged. — that the cable entry is leaking. <p>If there is oil in the stator casing, the cause may be:</p> <ul style="list-style-type: none"> — that the inner mechanical seal (40) is damaged. Contact a Flygt service shop. — that an O-ring (23) is damaged.
Cable entry	<p>Make sure that the cable clamps are tight.</p> <p>If the cable entry leaks:</p> <ul style="list-style-type: none"> — check that the entry is firmly tightened into its bottom-most position. — cut a piece of the cable off so that the seal sleeve (76) closes around a new position on the cable. — replace the seal sleeve (76). — check that the seal sleeve (76) and the washers (75) conform to the outside diameter of the cables.
Cables	<p>Replace the cable if the outer jacket is damaged. Make sure that the cables do not have any sharp bends and are not pinched.</p>
Level sensors or other level equipment	<p>Check function. Clean, adjust, replace or repair damaged level sensing equipment. Follow the instructions for the level sensing equipment in question.</p> <p>NOTE! The level sensor contains a mercury switch. Damaged sensors should therefore be disposed of in a proper manner.</p>
Starter equipment	<p>If faulty, contact an electrician.</p>

3041.281

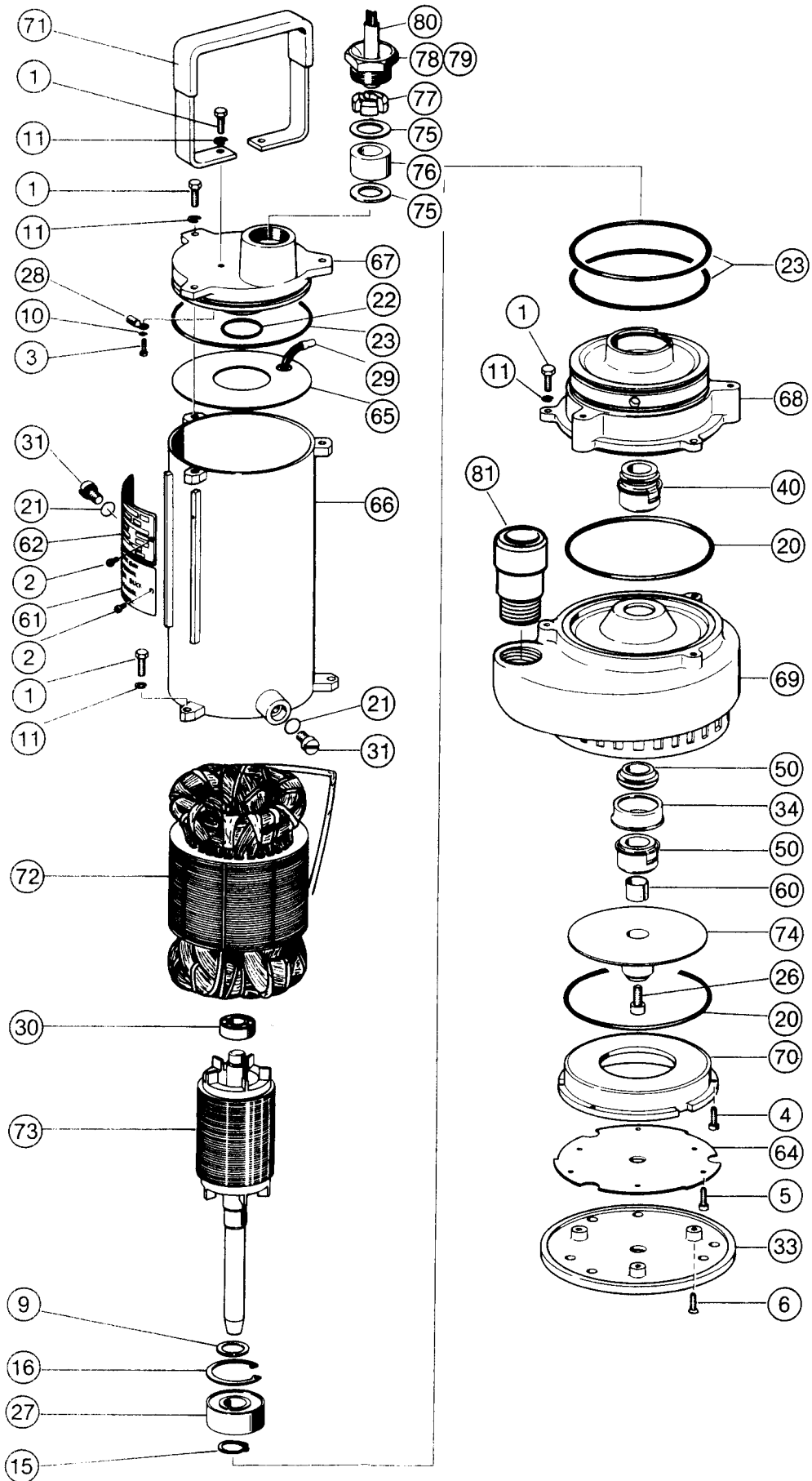

Inspection of	Action
Monitoring equipment (should be checked often)	<p>Follow the instructions for monitoring equipment.</p> <p>NOTE! The thermistors must not be connected to a higher voltage than 2.5 V.</p> <p>Check:</p> <ul style="list-style-type: none"> — signals and tripping function. — that relays, lamps, fuses and connections are intact. <p>Replace defective equipment.</p>
Rotation direction of pump (requires voltage)	<p>Transpose two phase leads if the impeller does not rotate clockwise as viewed from above. Rotation in the wrong direction reduces the capacity of the pump and the motor may be overloaded. Check the direction of rotation, during non-load every time the pump is reconnected.</p>
Pipes, valves and other peripheral equipment	<p>Repair faults and notify supervisor of any faults or defects.</p>
Insulation resistance in the stator	<p>Use insulation tester. With a 1000 V-DC megger the insulation between the phases and between any phase and earth (ground) should be $> 1 \text{ M}\Omega$.</p>

Changing the oil

Oil casing

WARNING. If the seal leaks, the oil casing may be under pressure. Hold a rag over the oil plug to prevent splatter.

Lay the pump on its side on a bench or over two supports.

Unscrew the oil casing screw (31).

Turn the pump so that the oil hole faces downwards.

In order to get out all the oil, the pump must be raised upright for a short while during drainage.

Fill up with 0.4 litres (0.42 US quarts) of new oil. Use an ordinary SAE 10W-30 motor oil. Always replace the O-rings of the oil hole screws. Put the screws back and tighten them. Tightening torque 10 Nm (7 ft lb). See fig. 1 on next page.

A paraffin oil approved by authorities (e.g. Mobil Whiterex 309) is recommended for raw or clean water pumping.

Replacing the impeller

Removing the impeller

WARNING! Worn impellers often have very sharp edges.

Clamp the pump in a vice with soft jaws.

Back off the screws (6) in the strainer plate (33) and removed it. See fig. 2.

Back off the screws (5) in the strainer bottom (64) and turn it $\frac{1}{8}$ of a turn. It can now be removed from its bayonett hold. See fig. 3.

Remove the suction cover (70).

See fig. 4.

Remove the impeller screw (26).

See fig. 5.

Pull off the impeller. Use impeller puller.

Do **not** pry off the impeller, since it can easily be damaged.

Installing the impeller

Make sure that the end of the shaft is clean and free of burrs. Polish off any flaws with fine emery cloth.

Clean and oil all sealing surfaces and O-rings.

Check:

— that the impeller is undamaged. Replace if necessary.

— that the conical sleeve (60) is seated on the shaft.

Grease end of shaft and impeller hub, then mount the impeller.

Tighten the impeller screw/nut.

Tightening torque 5 Nm (4 ft lb).

Check that the impeller can be rotated by hand.

Mount the suction cover (70) and then place the strainer bottom (64) in position at the pumphousing bottom (69). Turn the strainer bottom $\frac{1}{8}$ of a turn so that the screws fit in their seats on the suction cover (70).

Tighten the screws (5) evenly.

Check that the impeller easily be rotated by hand mount the strainer plate (33).

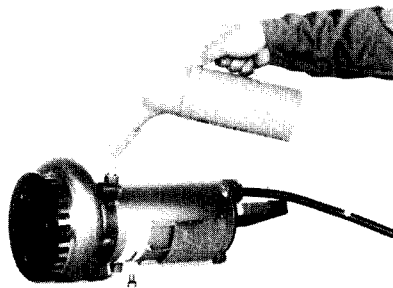

figure 1

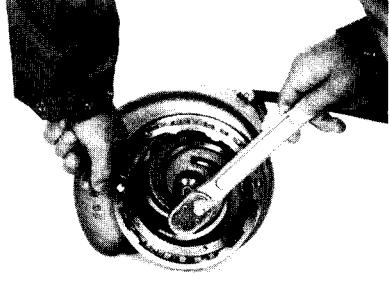

figure 5

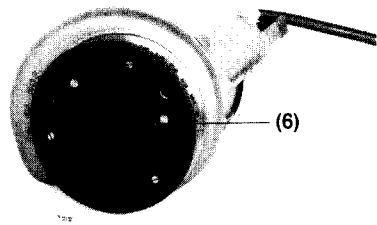

figure 2

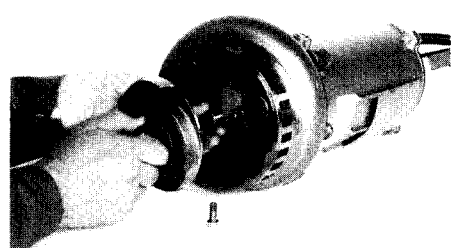

figure 6

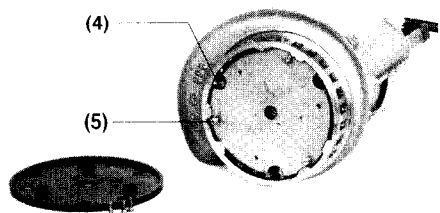
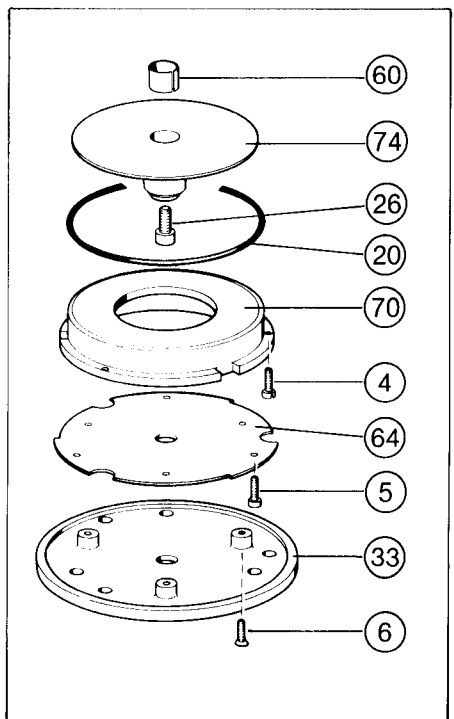

figure 3



figure 4



ACCESSORIES AND TOOLS

Level sensor

Flygt supplies level sensors suited for different liquid densities and with different cable lengths. See separate brochure.

Start and control equipment

Flygt has suitable start and control equipment for the pump. Contact Flygt for further information.

TOOLS

Besides ordinary standard tools, the following tools are required in order to perform the necessary care and maintenance of the pump:

Order No.	Description
84 13 60	Puller

For further information on tools, see Flygt's Tool Catalogue.

FAULT TRACING (TROUBLESHOOTING)

A universal instrument (VOM), a test lamp (continuity tester) and a wiring diagram are required in order to carry out fault tracing on the electrical equipment.

Fault tracing shall be done with the power supply disconnected and locked off, except for those checks which cannot be performed without voltage.

Always make sure that there is no one near the pump when the power supply is turned on.

Use the following checklist as an aid to fault tracing. It is assumed that the pump and installation have formerly functioned satisfactorily.

Electrical work shall be performed by an authorized electrician.

Follow local safety regulations and observe recommended safety precautions.

1. Pump fails to start

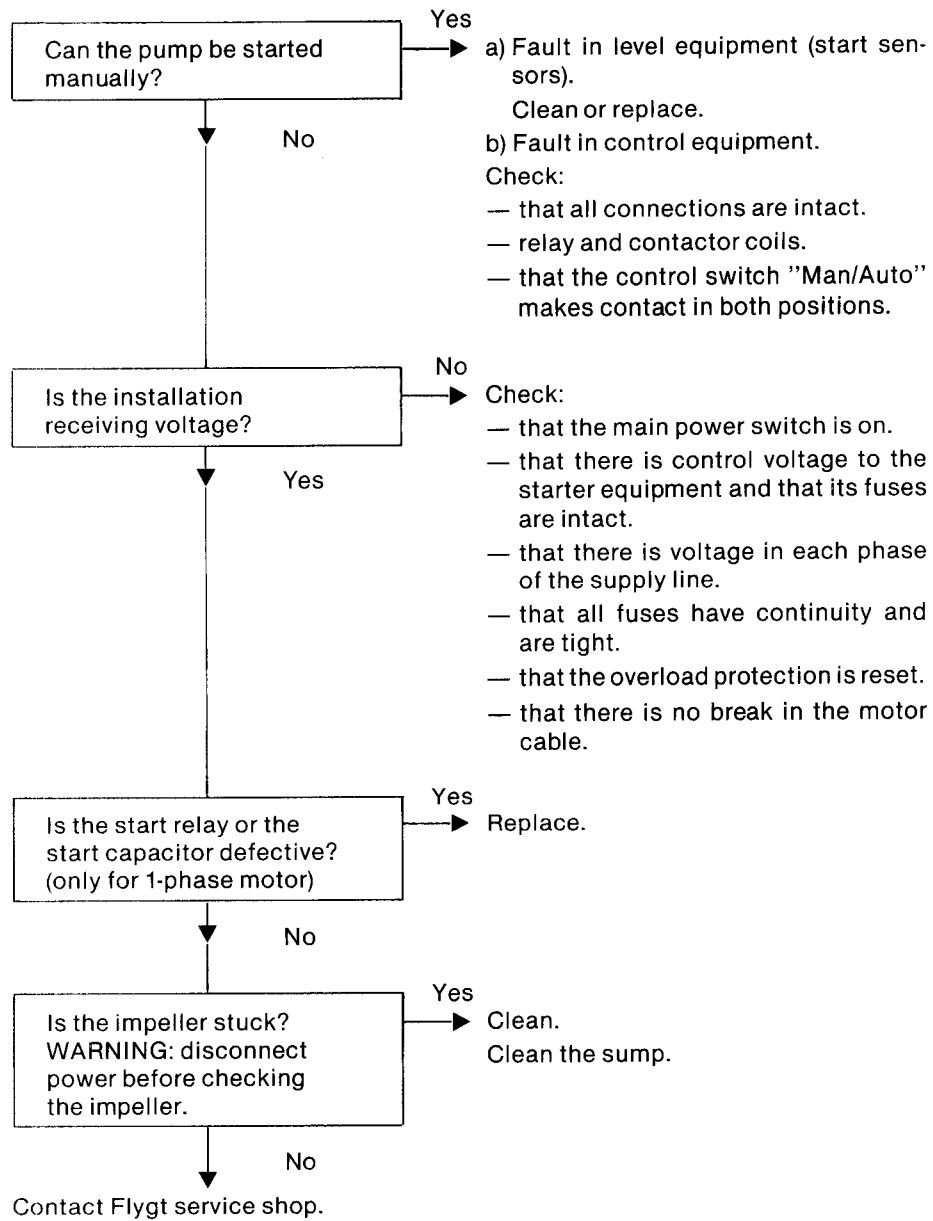

2. Pump starts but motor protection trips

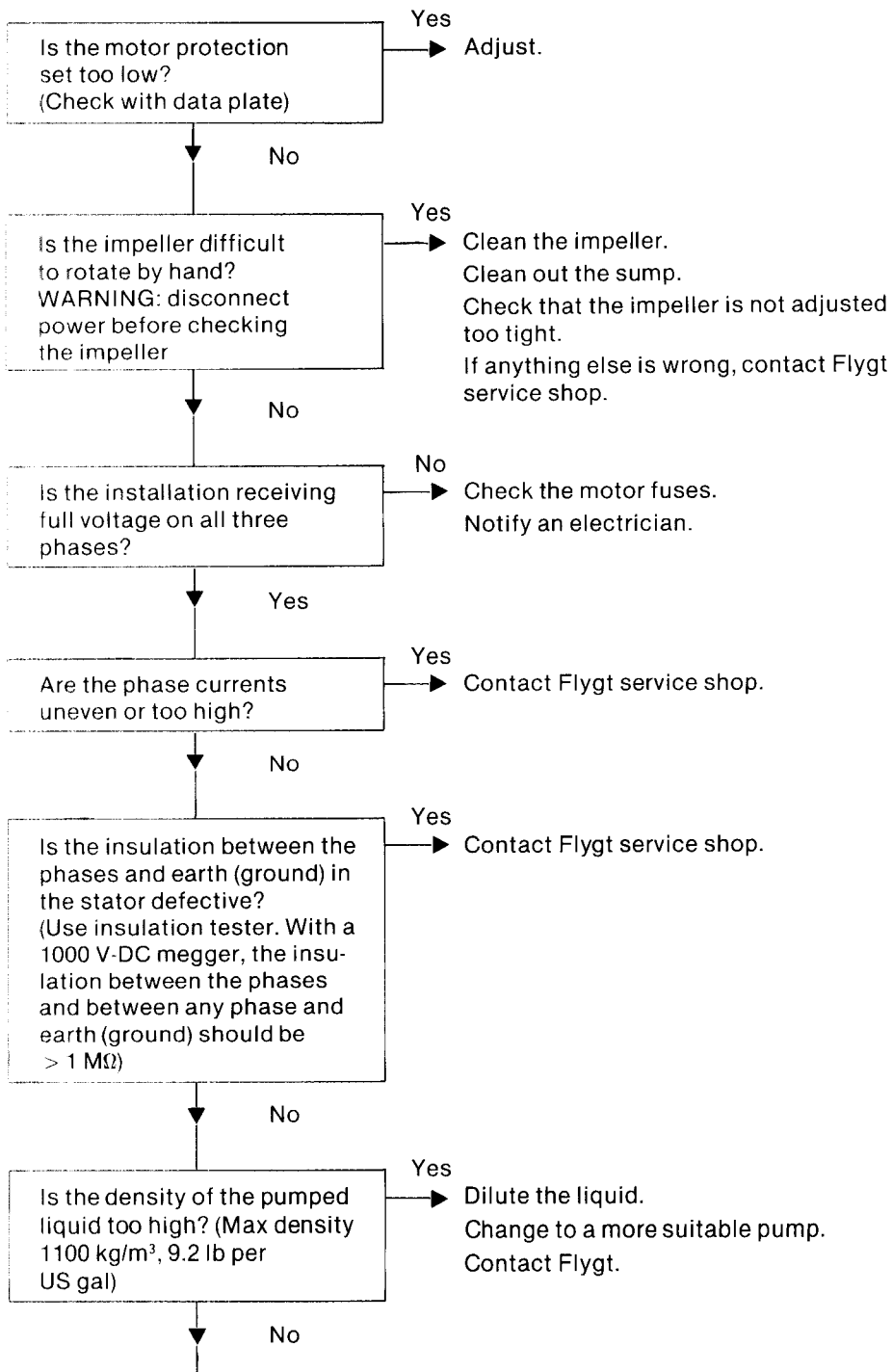

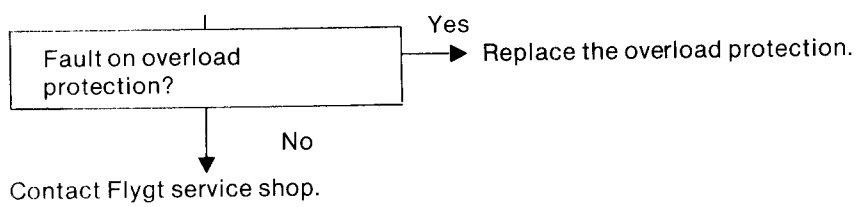

3. The pump does not stop

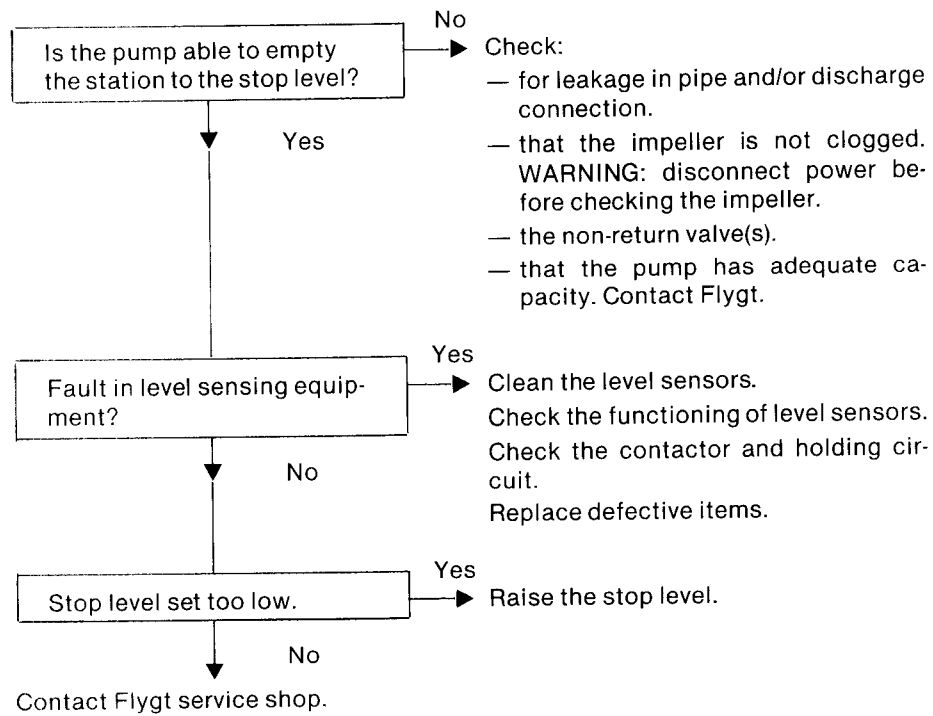

4. The pump starts-stops-starts in rapid sequence

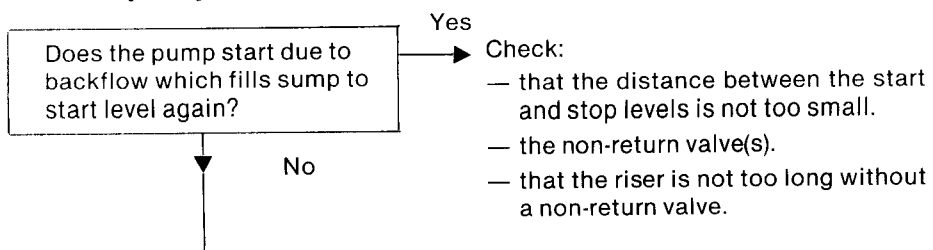

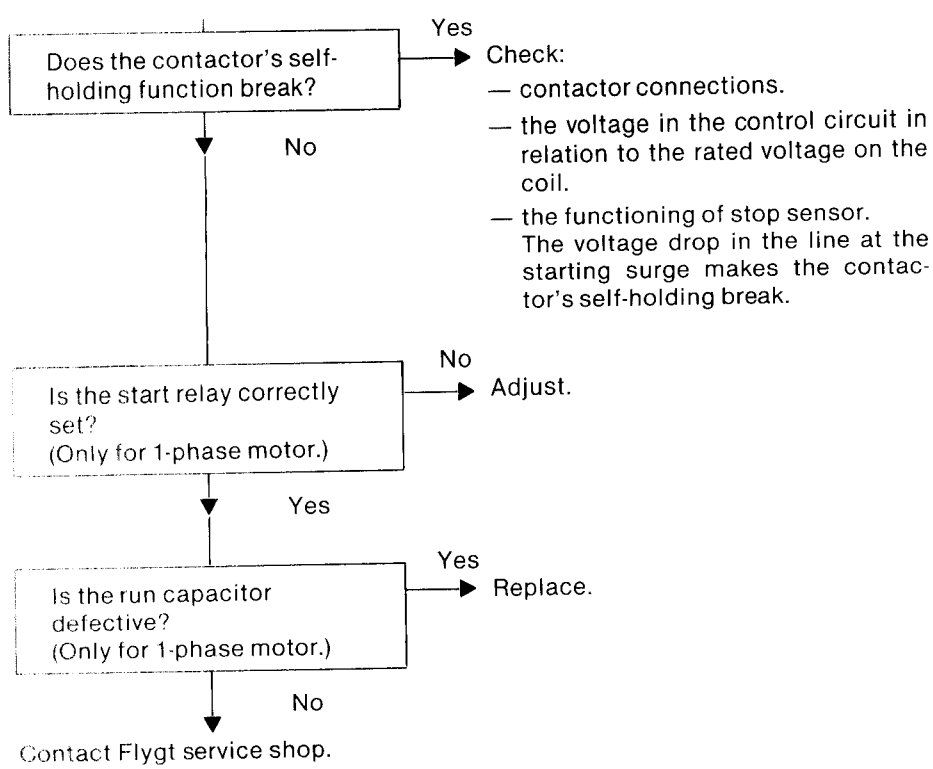

5. Pump runs but delivers too little or no water

Check:

- direction of rotation of pump, see "Before starting".
- that valves are open and intact.
- that pipes, impeller and strainer are not clogged.
- that the impeller rotates easily.
- for leakage in the pump installation.
- for wear on wear ring, impeller, pump casing/flange, suction bottom, diffuser disc, diffuser.

See also under "Inspection".

Do not override the motor protection repeatedly if it has tripped.

Service log

Most recent service date	Pump No.	Hours of operation	Remarks	Sign.

Service log

Most recent service date	Pump No.	Hours of operation	Remarks	Sign.

