



Workshop Manual

2151



Contents

How to use the Workshop Manual _____	2
Safety precautions _____	3
Data plate interpretation _____	4
Caution statement for MSHA _____	5
Tools _____	6
Technical data _____	8
Electrical connections _____	9
Dismantling _____	12
Assembly _____	22
Exploded view _____	38

How to use the Workshop Manual

This Workshop Manual describes how to dismantle and assemble pump 2151.

This operative part of the manual has a description of the operations and numbered illustrations of different work operations.

In the end you will find exploded views.

We would also like to point out that the practical work involved in compiling this manual has been performed under extremely favourable conditions. We have dismantled and assembled a brand new product. A product which has been in use for a longer period of time has acquired a "patina" and other working methods besides those recommended here will sometimes have to be used.

Flygt renounces all responsibility for the work done by untrained, unauthorized personnel.

Safety precautions

Safety symbols



DANGER!

Is used when there **will be** a risk to cause **severe injury** to people, **death** or **considerable damage** to property.



WARNING!

Is used when there **can be** a risk to cause **severe injury** to people, **death** or **considerable damage** to property.



CAUTION!

Is used when there **will be** or **is** a risk to cause **smaller injury** to people, or **smaller damage** to property.

NOTE!

Is used to pay attention to installation, use, operation or service information that is important but involved with any risk.

Precautionary measures

In order to minimize the risk of accident in connection with service work, the following rules should be followed:

1. Before starting work on the pump, make sure that the pump is isolated from the power supply and cannot be energized.
2. Bear in mind the risk of accidents. Make sure that the machine or parts of the machine cannot roll or fall over and injure people or damage property.
3. Make sure that the lifting equipment can handle the weight you want to lift and that it is in good condition.
4. Don't work under suspended load.
5. Carry out the work on a sturdy workbench.
6. Bear in mind the danger of electrical accidents.
7. Check that tools and other equipment are in good condition.
8. Bear in mind health hazards. Observe strict cleanliness.
9. When carrying out repair work take care to avoid injury by cutting or pinching.
10. Make sure you have a first-aid box near at hand.

Follow all other health and safety regulation, local codes and ordinances.

Following symbols are used in this manual:



For electrical related warnings.



For all other warnings.

Data plate interpretation

General data plate

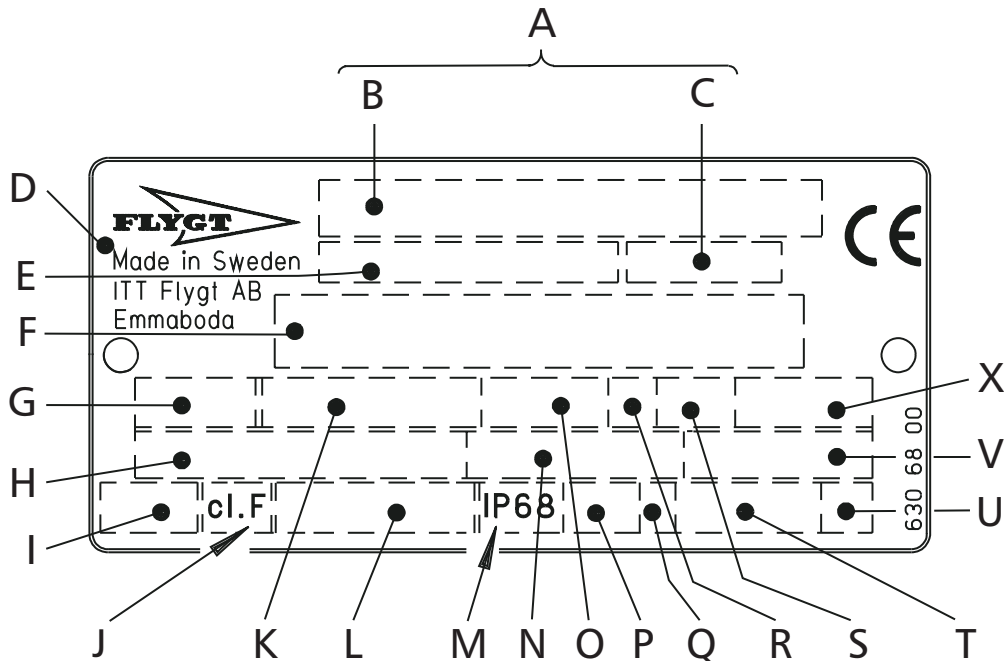

A	Serial number	M	Degree of protection
B	Product code + Number	N	Rated current
C	Curve code / Propeller code	O	Rated speed
D	Country of origin	P	Max. submergence
E	Product number	Q	Direction of rotation: L=left, R=right
F	Additional information	R	Duty class
G	Phase; Type of current; Frequency	S	Duty factor
H	Rated voltage	T	Product weight
I	Thermal protection	U	Locked rotor code letter
J	Thermal class	V	Power factor
K	Rated shaft power	X	Max. ambient temperature
L	International standard		

Caution statement for MSHA

Federal Safety Regulations, as outlined in the applicable provisions of Title 30 of the Code of Federal Regulations, require that in order to maintain "permissibility" of this equipment the following conditions must be satisfied:

1. General Safety

Frequent inspections shall be made. All electrical parts, portable cable and wiring shall be kept in a safe condition. There shall be no openings into the casings of the electrical parts. The machine frame shall be effectively grounded. The power wires shall not be used for grounding. The operating voltage shall match the voltage rating of the motor.

2. Service and Repair

Inspections, service and repairs shall only be made when the portable cable is disconnected from the power supply. Work must be performed by trained personnel (preferably the manufacturer or his agent) to insure that the permissible pump is restored to its original state of safety in regard to all flame-arresting paths. Use replacement parts exactly as those furnished by the manufacturer. When cable entries are disturbed on pump or permissible control, they shall be reassembled in the approved manner and with parts identical to the parts of the original certification.

3. Fastenings

All bolts, nuts, screws and threaded covers shall be properly tightened and secured.

4. Cables

A flame-resistant portable cable, bearing a MSHA assigned identification number, adequately protected by an automatic circuit-interrupting device shall be used. Special care shall be taken in handling the cable to guard against mechanical injury and wear.



WARNING!

Failure to restore the permissible equipment to its original state of safety will void the MSHA APPROVAL. The creation of a safety hazard will subject the owner/operator of a mine to citations and penalties under the law.

Tools

<i>Part No.</i>	<i>Denomination</i>	<i>Range of use</i>
83 95 42	Pump	Inspection room
84 08 02	Circlip plier (SGA 19-60 mm)	Mechanical seal unit
84 08 11	Circlip plier (SGH 85 165 mm)	Outer bearing
84 08 60	Crow bar (2x)	Mechanical seal unit
84 10 16	Ratchet handle	Sockets
84 11 40	Combination wrench	Level switch
84 13 03	Hexagon bit adapter	Terminal´s rail, earthing
84 13 05	Hexagon bit adapter	Plugs, connection cover, lift handle
84 13 06	Hexagon bit adapter	Impeller screw, cable entry, pump housing
84 13 62	Puller	Inner bearing
84 14 77	Hexagon bit adapter	Seal housing cover
84 14 80	Hexagon bit adapter	Impeller
84 14 89	Allen keys set (9x)	Mechanical seal unit
84 15 55	Extension bar (L= 125 mm)	Sockets
332 91 00	Puller	Spring
394 69 00	Stator lifting tool	Stator
398 22 00	Mounting sleeve	Mechanical seal
398 31 00	Mounting sleeve	Mechanical seal unit
608 20 00	Mounting/dismounting tool	Main bearing
608 23 00	Stand	Pump fixation

Dismantling/Assembling tool 608 20 00

Dismantling

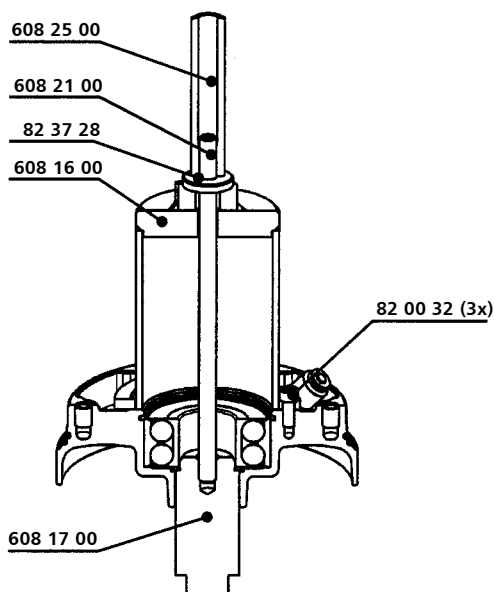
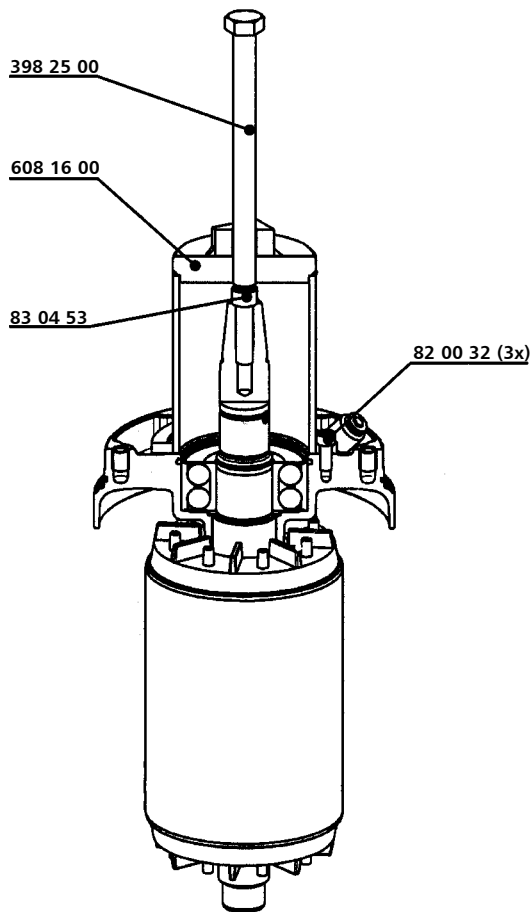

Assembling

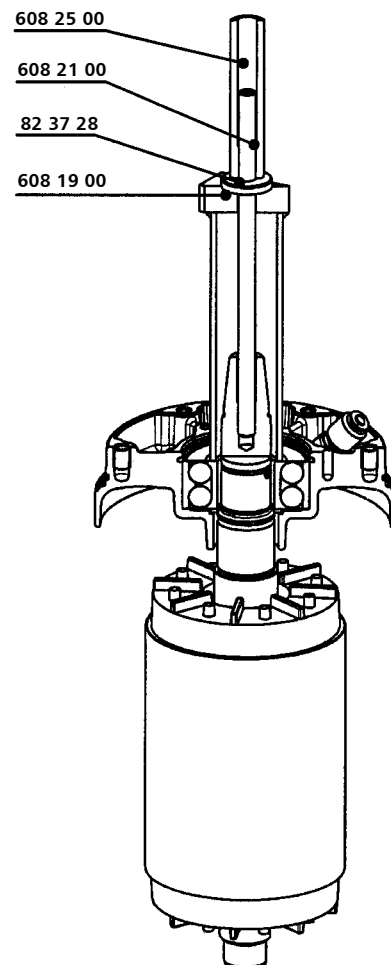
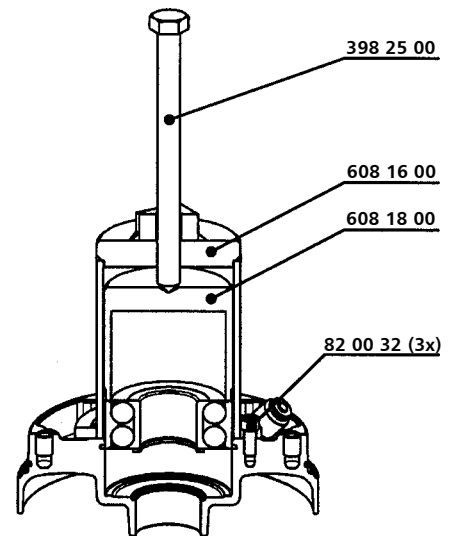

Technical data

Lubricants

Part No.	Denomination
90 17 52	Oil (Mobil Whiterex 309)
90 18 00	Oil (Castrol iloform BWN 205)

Winding data

Stator No.	Ohm per phase
298 85 28	0.098
298 85 29	0.111
298 85 30	0.309
298 85 34	0.144
298 85 35	0.347
298 85 38	0.435
298 85 40	0.388
298 85 44	0.523
298 85 50	0.643
298 85 52	0.828
298 85 55	0.881
298 86 37	0.088

Tightening torques

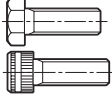
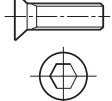
Material Thread	Stainless (A2, A4)			
	Property class			
	70			
	Nm	lb ft	Nm	lb ft
M5	4.1	3	2.0	1.5
M6	7	5.2	4.1	3
M8	17	5.2	4.1	3
M10	33	24.3	17	12.5
M12	57	42	33	24.3
M16	140	103	57	42
M20	273	201	100	74
M24	472	348	140	103
Type of screw				

Electrical connections

50/60 Hz, 3~ with terminal board

SUBCAB 4G/SUBCAB AWG*:

Mains	Lead	Pump terminal board
L1	Brown (Red*)	U1
L2	Blue (White*)	W1
L3	Black (Black*)	V1
Earth	Yellow/green	
Groundcheck	Yellow*	GC
T1	Black/orange*	T1
T2	Black/blue*	T2

The stator leads are colour-marked as follows:

Stator leads	Connection to terminal board
U1, red	U1
V1, brown	V1
W1, yellow	W1
V2, blue	V2
W2, black	W2
U2, green	U2

Connect the control leads from the motor control circuit to T1 and T2.

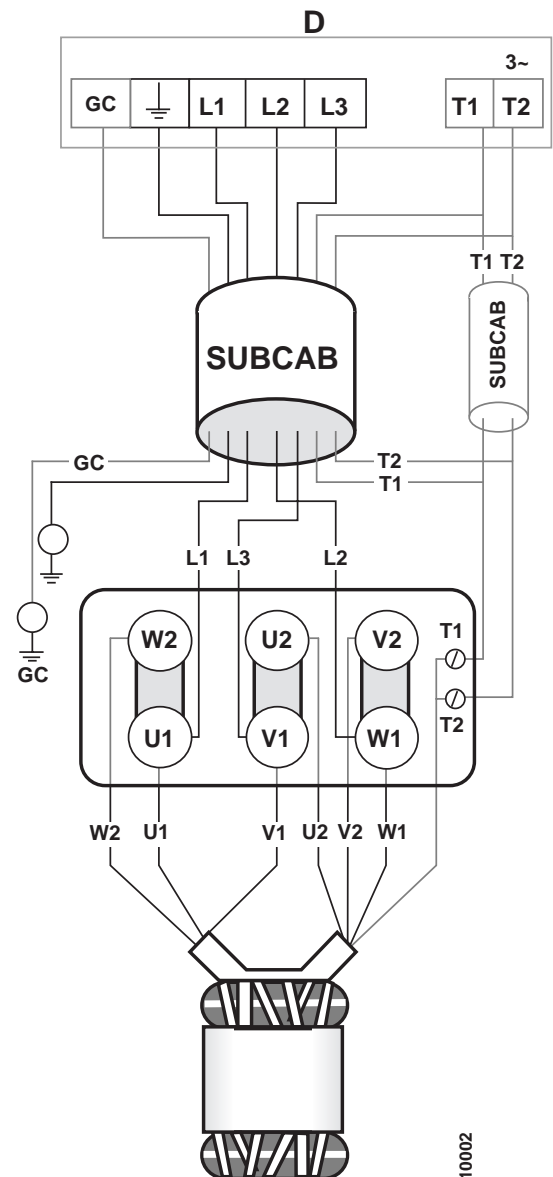
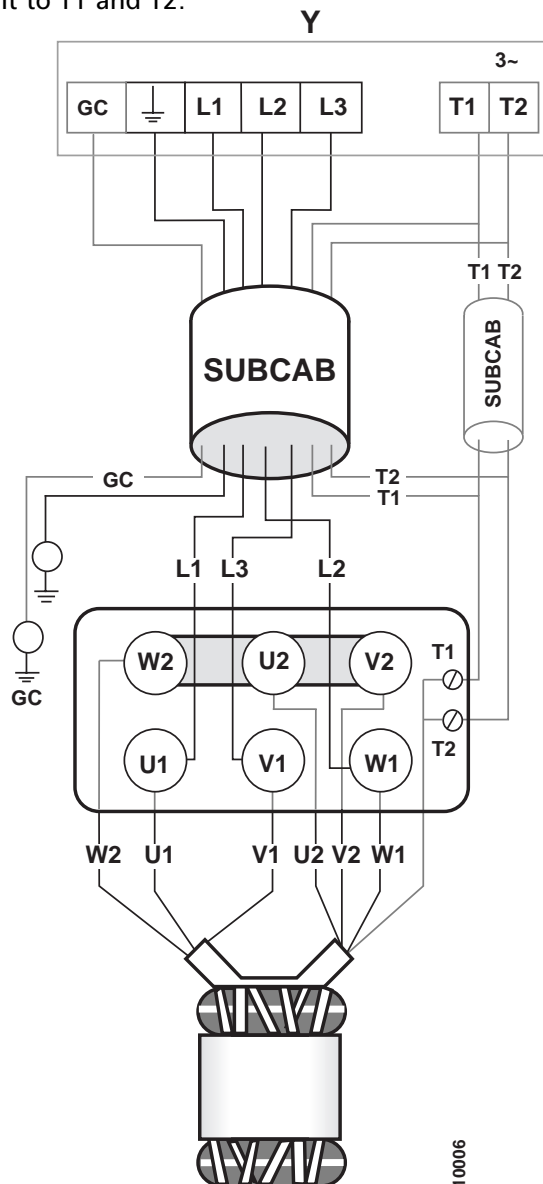

50/60 Hz, 3~ with terminal board

SUBCAB 4G/SUBCAB AWG*:

Mains	Lead	Pump terminal board
L1	Brown (Red*)	U1
L2	Blue (White*)	W1
L3	Black (Black*)	V1
Earth	Yellow/green	
Groundcheck	Yellow*	GC
T1	Black/orange*	T1
T2	Black/blue*	T2

Connect the control leads from the motor control circuit to T1 and T2.

The stator leads are colour-marked as follows:

U1 (S1)	- red
V1 (S2)	- brown
W1 (S3)	- yellow
U2 (S4)	- green
V2 (S5)	- blue
W2 (S6)	- black
U5 (S7)	- red
V5 (S8)	- brown
W5 (S9)	- yellow

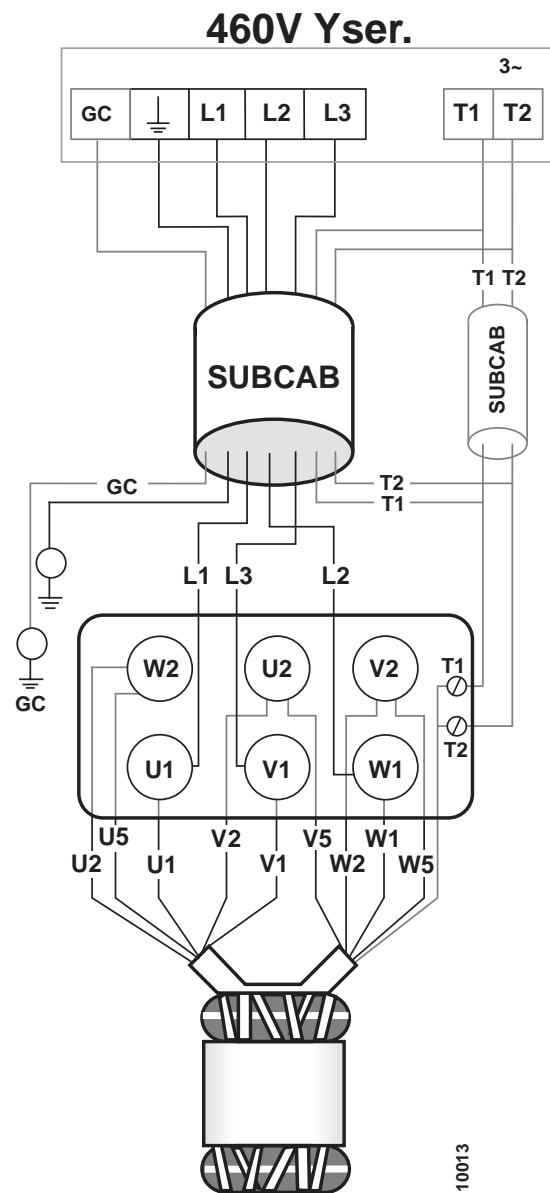
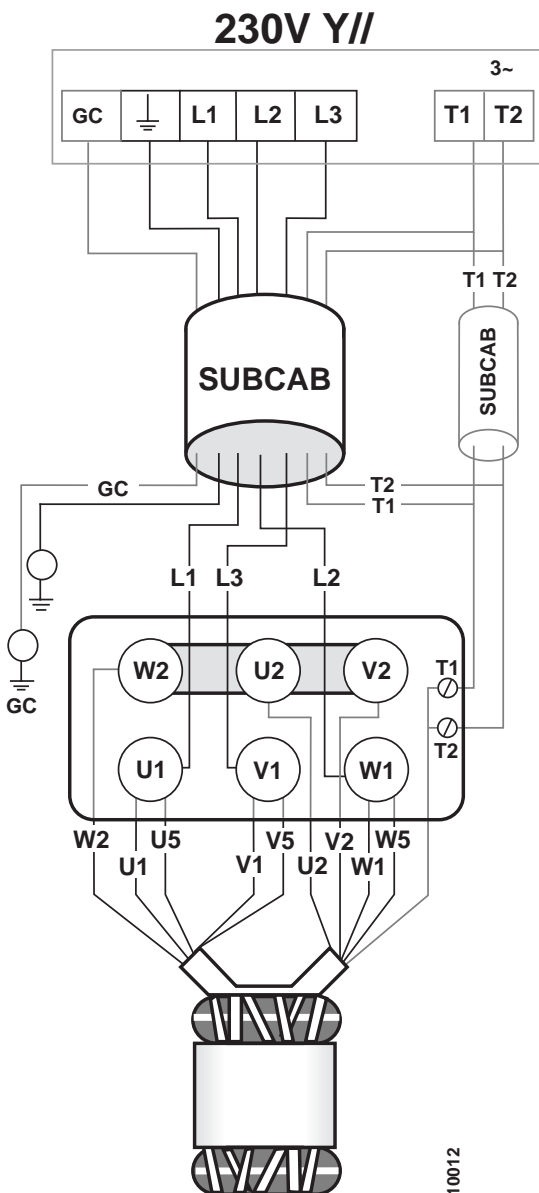

50/60 Hz, 3~ with terminal board

SUBCAB 7G

Mains	Lead	Pump terminal board
L1	Black 1	U1
L2	Black 2	W1
L3	Black 3	V1
L1	Black 4	W2
L2	Black 5	V2
L3	Black 6	U2
Earth	Yellow/green	
T1	Black T1	T1
T2	Black T2	T2

The stator leads are colour-marked as follows:

U1 (S1)	– red
V1 (S2)	– brown
W1 (S3)	– yellow
U2 (S4)	– green
V2 (S5)	– blue
W2 (S6)	– black

Connect the control leads from the motor control circuit to T1 and T2.

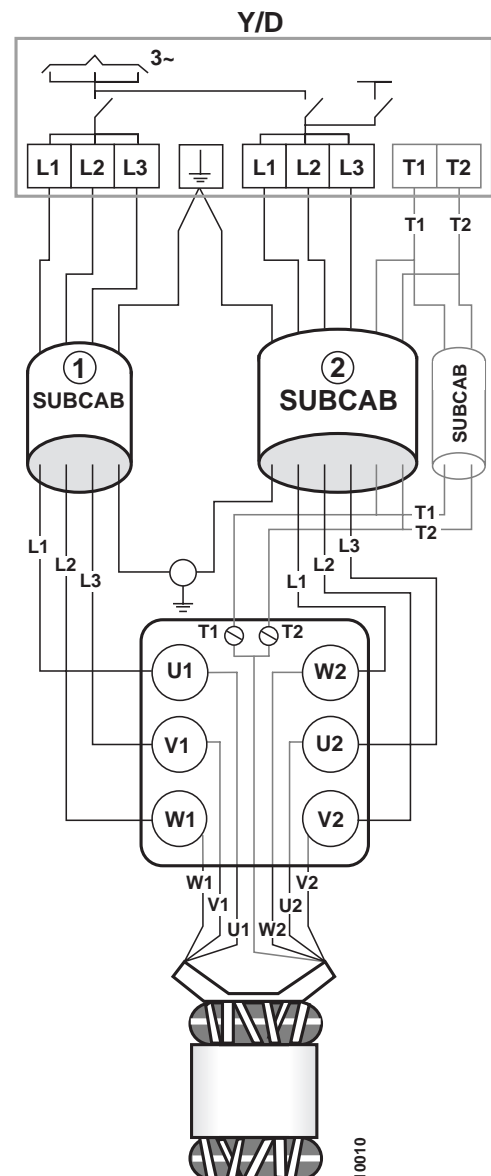
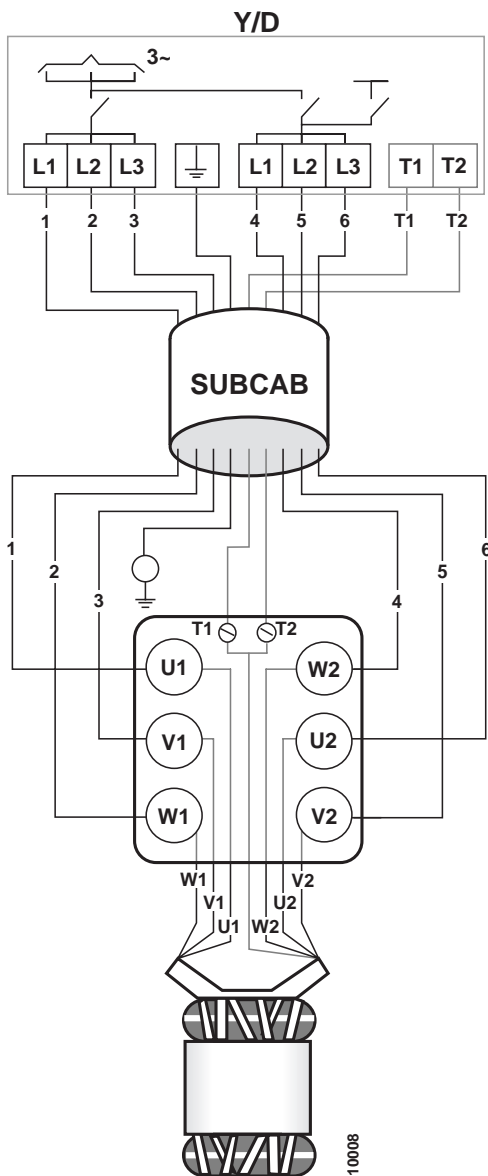

Dismantling

Before starting

Before starting the work on the machine, make sure that all tools are at hand and that O-rings and any other part that are to be replaced are set out.

Make sure that the product is isolated from the power supply before starting work.



DANGER

Before starting work on the machine, make sure that the machine is disconnected from the power supply and cannot be energized.

1. Remove the discharge connection.

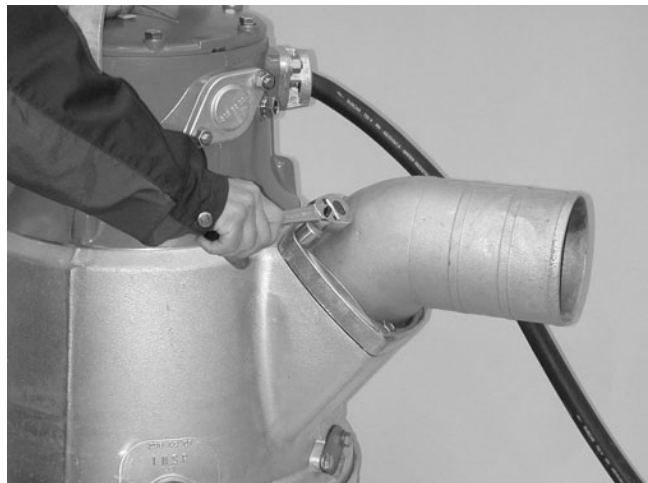

2. Remove the junction box cover and disconnect the motor cable from the terminal board.

Undo the cable entry and pull the motor cable out of the junction box.

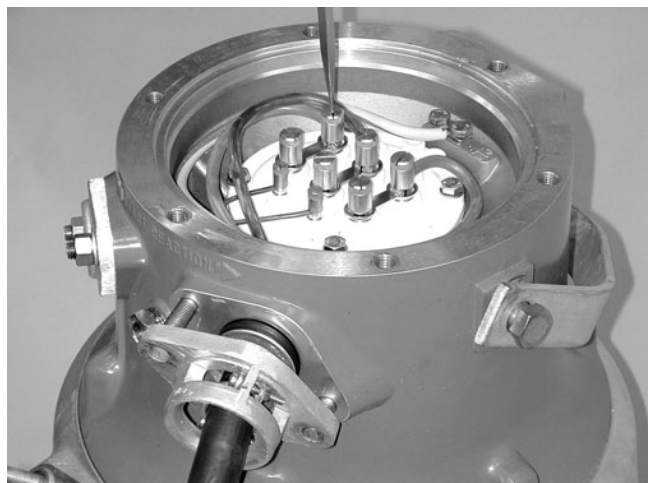

3. Unscrew the terminal board and disconnect the stator leads underneath the board.

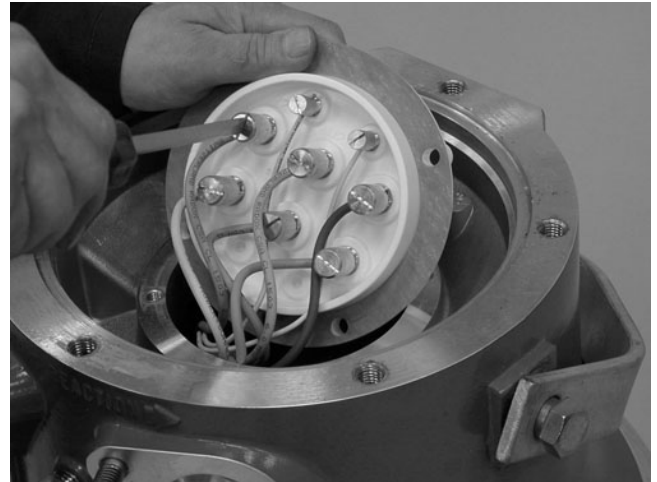

4. Assemble the stand No. 608 23 00 in the same screw holes as the junction box cover.



5. Drain the oil by unscrewing the oil hole screw at "Oil out".

NOTE!

Keep a bucket under the oil plug when it is removed in order to prevent oil platter in case the oil casing is under pressure.

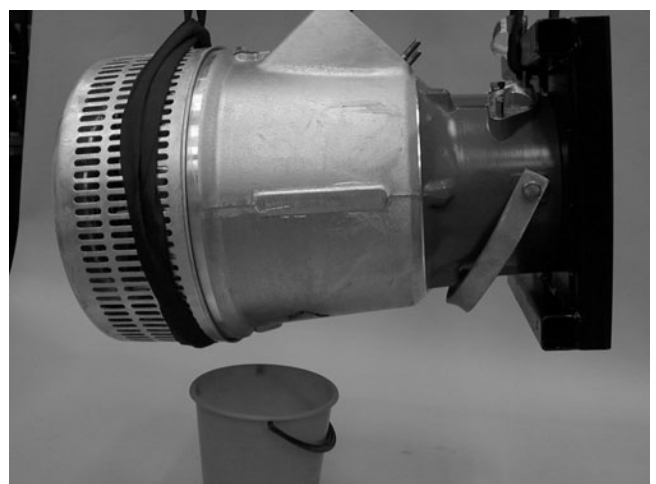

6. Lift the pump, see pic. Fasten two lifting eye bolts, M 12, in the bottom of the strainer.



7. Lift the pump upside down and place it on the stand.

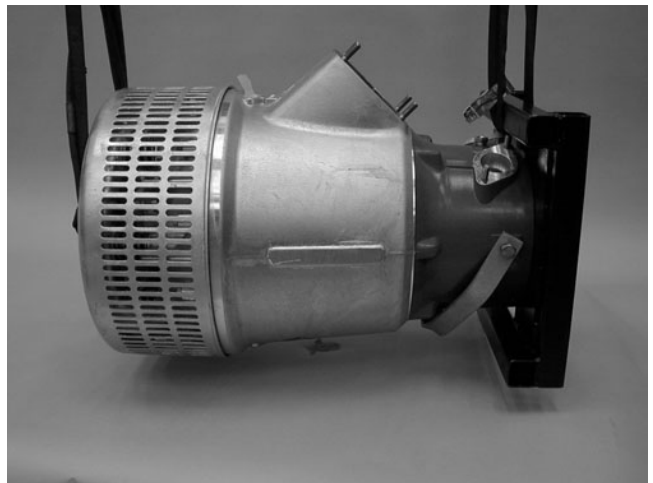

8. Dismantle the strainer, remove the springs and the distance tubes.



9. Remove the suction cover.

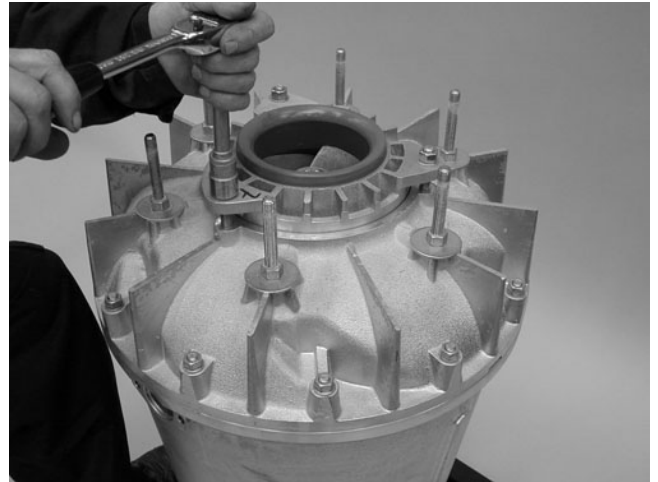

10. Remove all the nuts that are holding the diffuser.

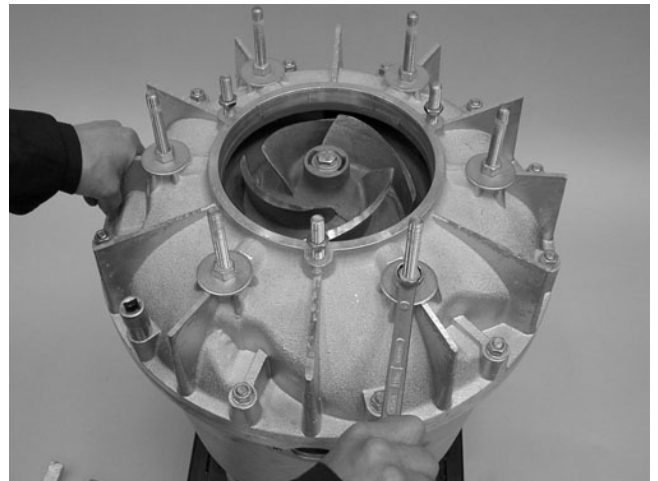

11. Separate the diffuser from the outer casing by gently prizing in the groove.

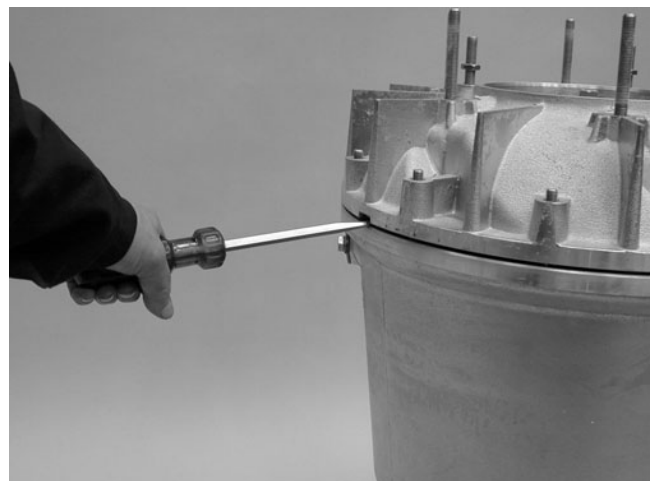

12. Loosen the studs in the oil casing.



13. Unscrew the impeller screw.



WARNING!
*Use protective gloves. Worn
impellers can have sharp edges.*

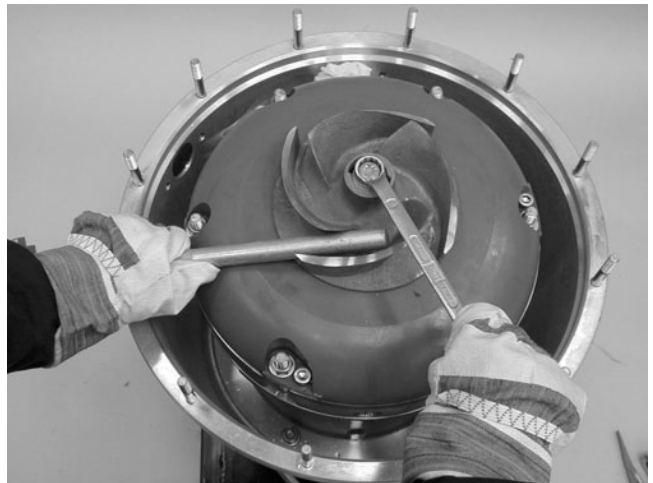

14. Pull off the impeller by screwing in a screw No. 81 40 21 (M16) into the threaded washer.



15. Remove the key and adjusting washers.



16. Remove the circlip with the circlip plier No. 84 08 02.

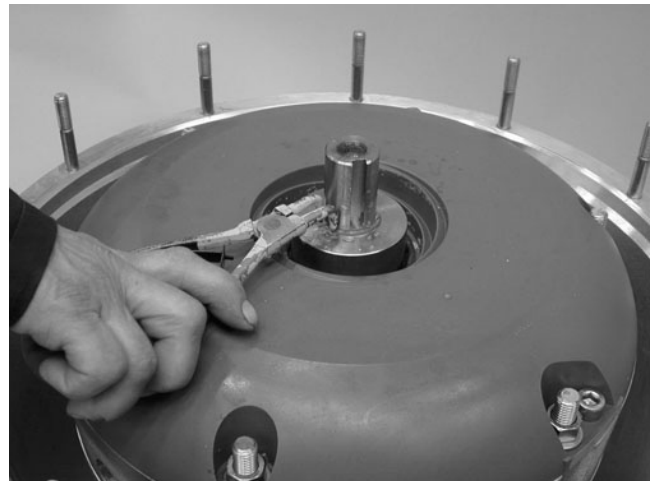

17. Carefully remove the outer seal.



18. Unscrew the hex socket screws and the nuts that hold the oil casing bottom.



19. Lift off the oil casing and its O-ring.

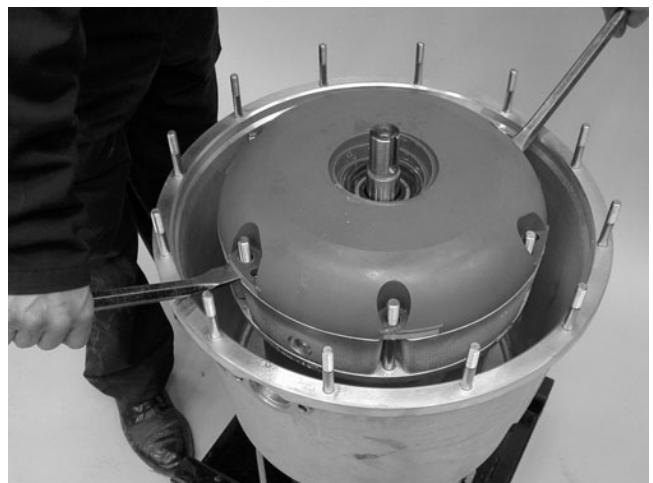

20. Press in the inner seal's stop ring and remove the lock spring by means of spring puller No. 332 91 00.



21. Remove the rotating part of the inner seal.
Use the tool No. 216 68 00.

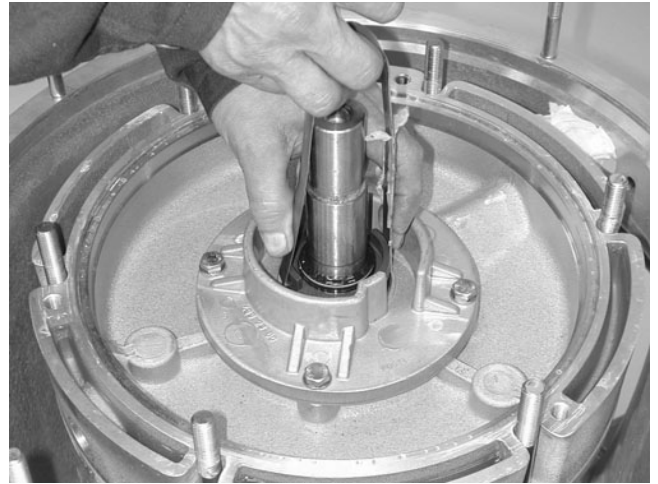

22. Unscrew the bearing cover.

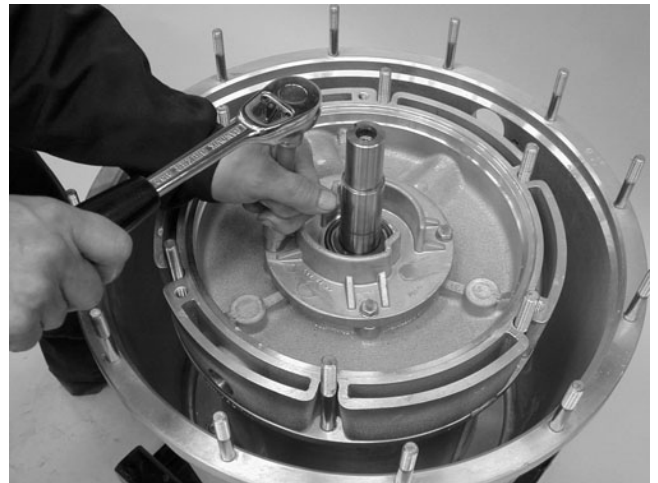

23. Loosen the outer casing from the stator housing.
Use a rubber hammer to avoid damage on the casing.



24. Fit a lifting eye bolt (M 12) in the shaft and lift out the rotor assembly and the lower bearing housing from the stator housing.

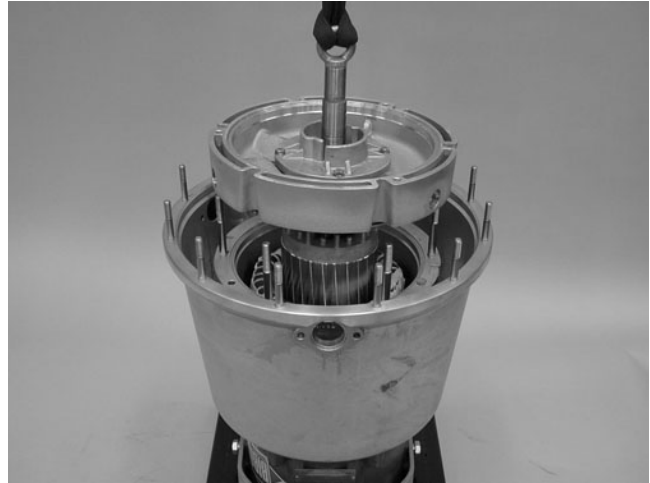

25. The bearing and the bearing holder are pulled off with tool No. 608 20 00.
The locking ring that is holding the bearing is removed with a circlip plier.

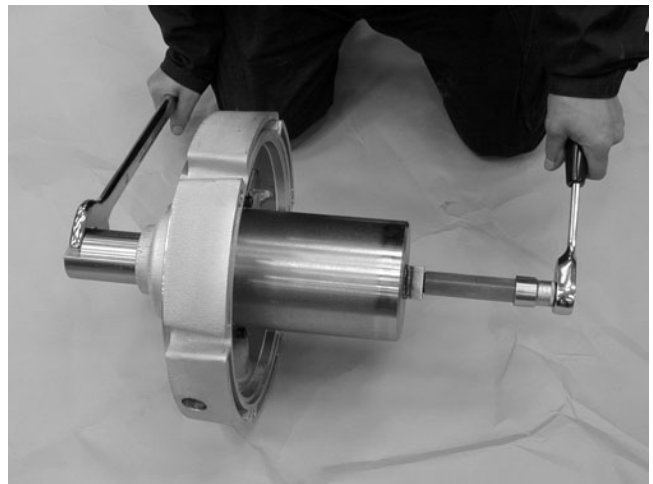

- 26.



- 27.** Assemble the stator puller nr 394 69 00.
Heat the stator casing to approx. 150°C (203°F) using an LP gas torch or blow lamps.
Heat rapidly and evenly all around.
When the stator casing has come loose and fallen the bottom (a couple of cm), extinguish the flame and lift out the stator.
Let the stator casing cool down.

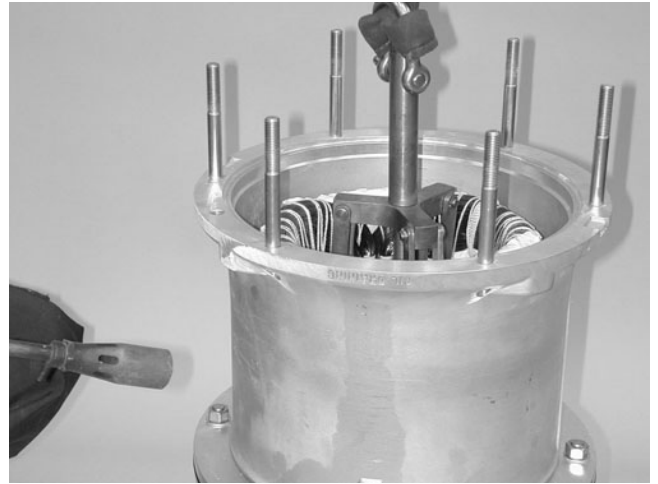

Assembly

Important!

Before starting assembly, do the following:

- Carefully clean all machined surfaces.
- Check that the O-ring grooves are clean and free of deep scratches, burrs or other irregularities.
- Grease the shaft and O-rings. Oil the sliding surfaces of seals.
- Lubricate all screws that have been removed before refitting them.
- Replace damaged or worn parts.
- Check the stator windings resistance.

Fit the stator assembly by first heating the stator casing to approx. 150°C (302°F).

Make sure that the locating pin on the outside of the stator assembly fits into the matching groove in the stator casing when the stator is lowered into the casing.

Make sure that the stator assembly bottoms out in the stator casing.

Allow the stator casing to cool.

1. Assembling of the bearing into the bearing holder is done with the tool No. 608 20 00.

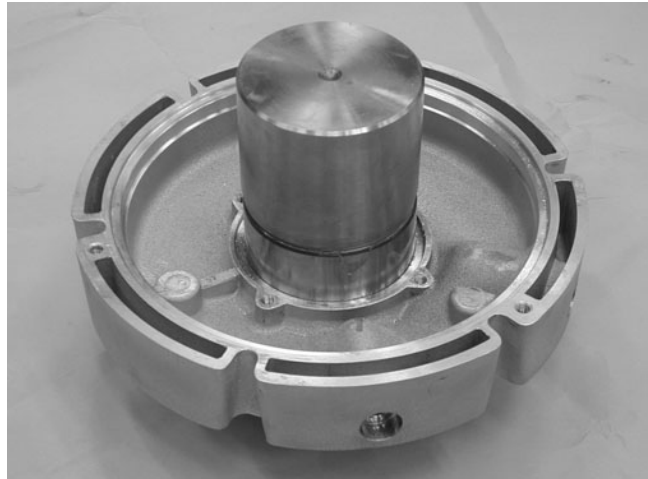

- 2.

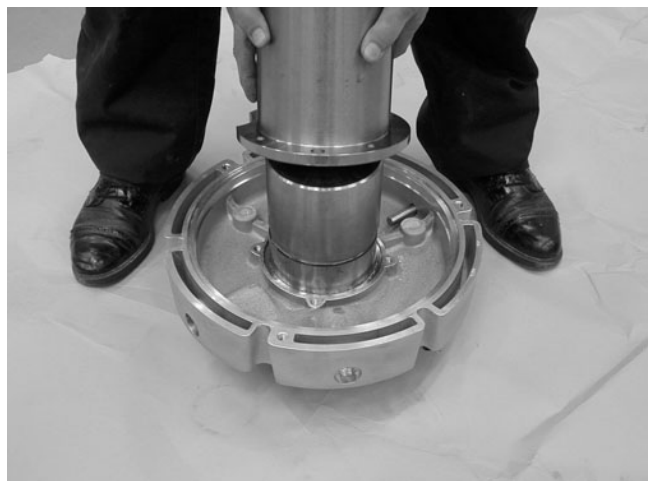

3.

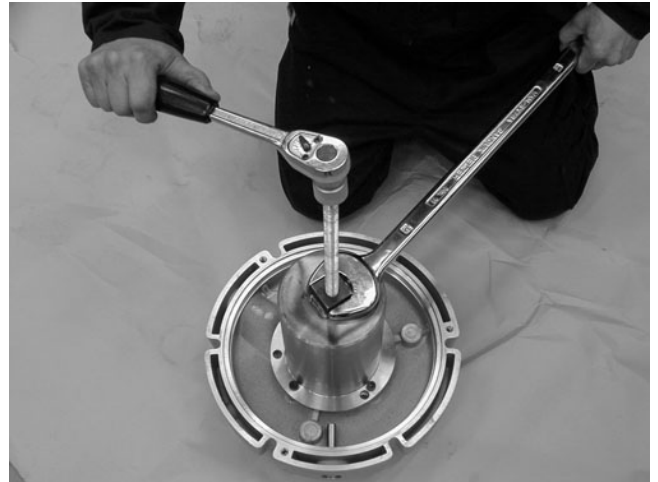

4. Fit the O-ring between the stator casing and the upper bearing housing.



5. Tuck the stator leads through the top.



6. Lower the stator casing over the upper bearing housing.

NOTE!

The mounting pin in the stator housing shall be positionen where there is no corresponding boss in the pump top.



7. Screw the upper bearing housing with the stator casing.

Tightening torque 60 Nm.

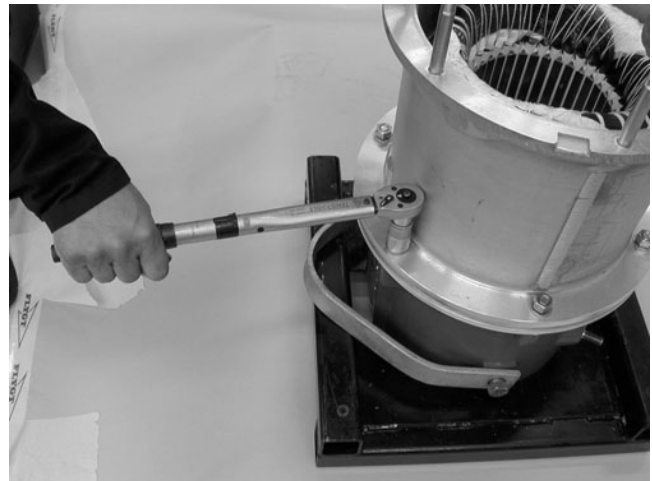

8. Fit the O-ring between the stator casing and the outer casing.



9. Fit the O-ring between the stator casing and the bearing holder.

Mount the shaft-rotor unit and the bearing holder.



10. The bearing holder is mounted on the shaft-rotor unit with the tool No. 608 20 00.

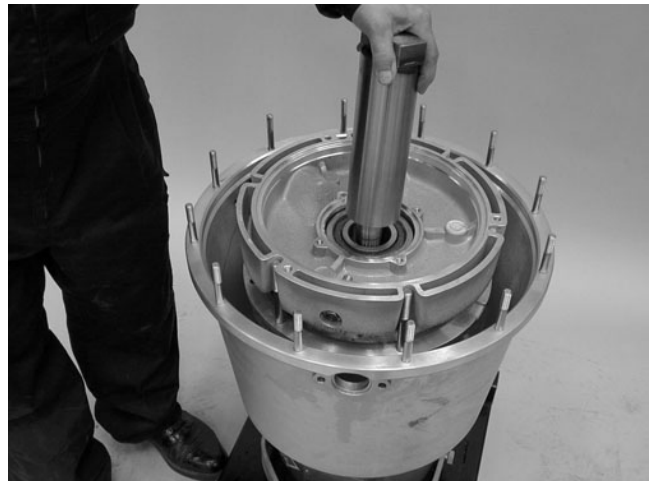

- 11.



12.



13. The washer and the retaining ring are mounted with the circlip plier.



14.



15. Make sure that the retaining ring correctly placed.



16. Fit the O-ring underneath the bearing cover.



17. Screw the bearing cover.
Tightening torque 60 Nm.



18. Fit the inner seal, use the mounting sleeve No. 398 31 00.

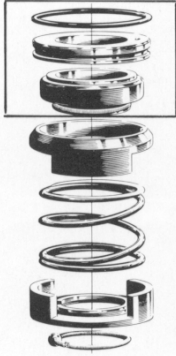

- 19.



20. Use the mounting socket No. 398 22 00 to press the seal.



21. Fit the O-ring onto the bottom of the oil casing.



22. Mount the oil casing and tighten the socket head cap screws, tightening torque, 30 Nm.



23. Place the six washers and tighten the nuts onto the oil casing, tightening torque, 60 Nm.



24. Fit the studs, tightening torque, 60 Nm.

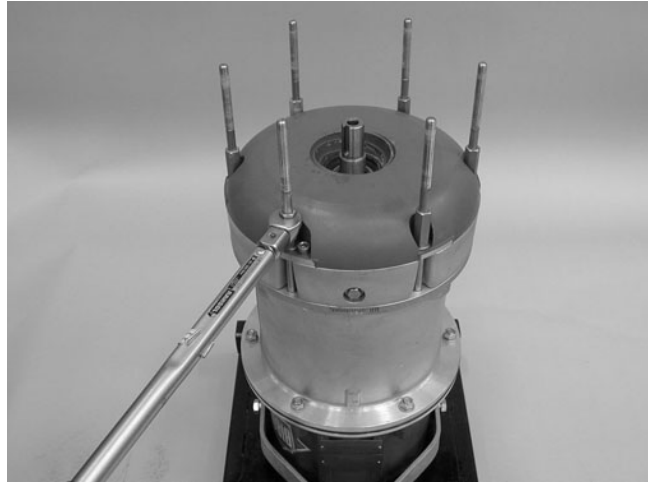

25. Fit the outer seal.



26.



27. Use the mounting sleeve No. 398 31 00 to fasten the circlip.

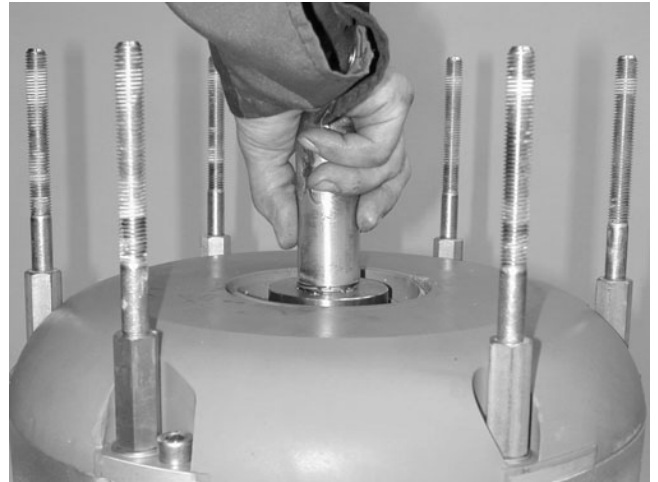

28. Make sure that the circlip is correctly placed in the groove.



29. Fit the key and then the necessary number of adjusting washers on the shaft to obtain the right clearance between the impeller and the oil casing.

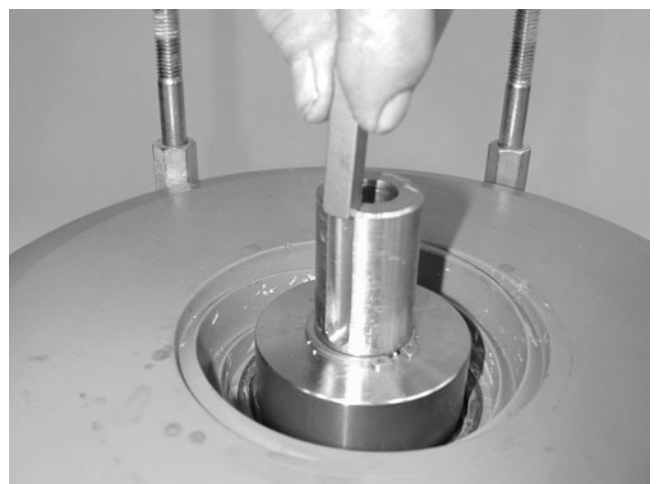

30. Fit the outer casing. Make sure that the holes for the oil plugs are aligned with the oil plugs in the stator casing.

Press the outer casing all the way down. If necessary, use a piece of wood to tap the upper edge of the casing until it feels tight.

Fit the impeller. Fit the special nut (54) into the impeller.



WARNING!

Use protective gloves. Worn impellers can have sharp edges.

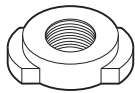

Special nut (54)

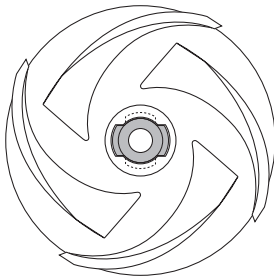

Screw the impeller, tightening torque, 60 Nm

Check the distance between the impeller and oil casing, 0.2 - 0.3 mm.

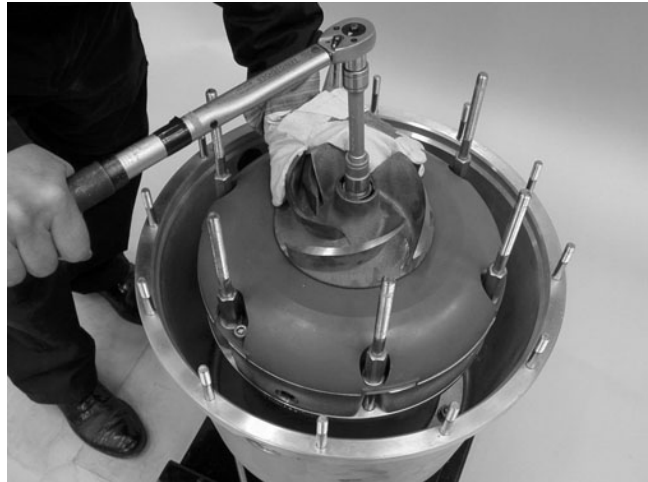

31. Fit the 6 washers between the studs och the diffusor.



32. Fit the diffuser.

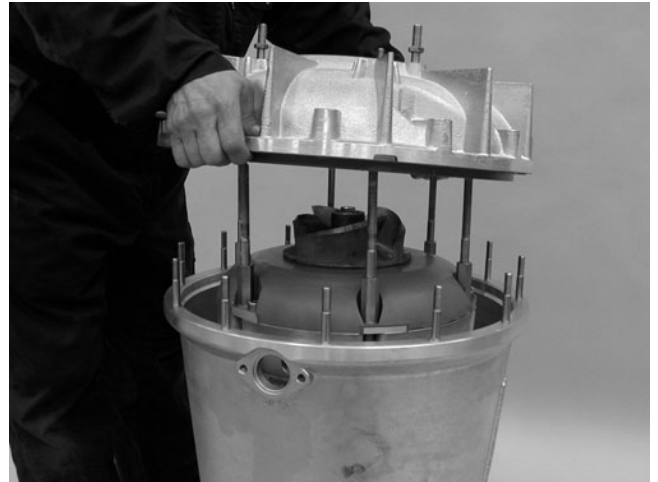

33. Fit the big washers onto the studs.

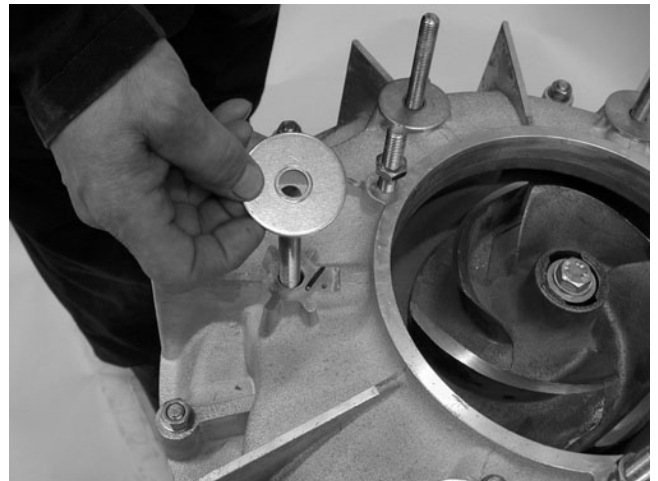

34. Tighten all the nuts.

The 12 lower nuts, tightening torque,
30 Nm.

The 6 upper nuts, tightening torque, 60 Nm.

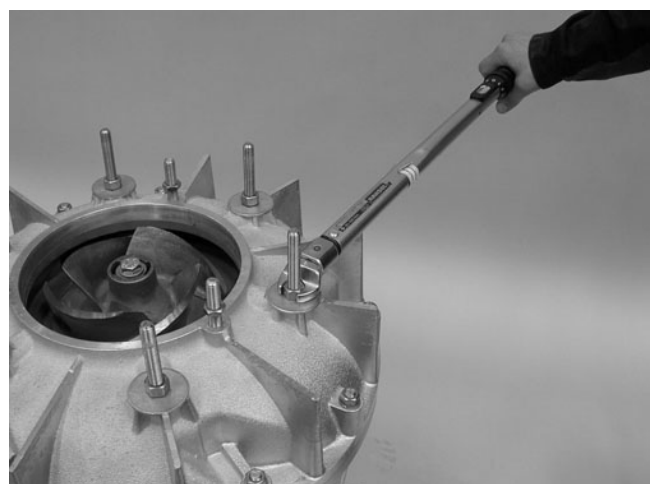

35. Fit the O-ring over the suction cover. Make sure it fits in the groove.



36. Assemble the suction cover. Check the distance between the impeller and the suction cover with a thickness gauge, 0.2 - 0.3 mm.

Make sure that the impeller can easily be rotated by hand.

Make sure that the suction cover is seated.



37. Tightening torque, 60 Nm.

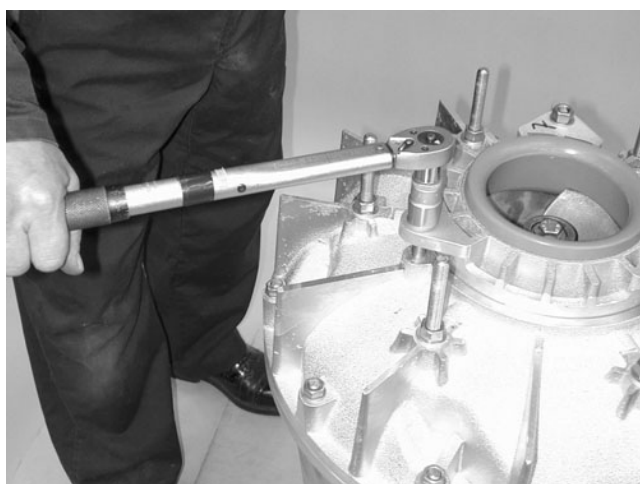

38. Fit the spacer sleeves and the springs underneath the strainer.



39. Tighten the 6 nuts, tightening torque, 60 Nm.
Do not forget the 6 washers, placed underneath the nuts.



40. Fit the oil screw in "Oil out".



41. Fill up with 4 litres (4.2 US quarts) of fresh oil.



42. Put a new O-ring on the oil screw. Tighten the screw, tightening torque, 17 Nm.

Fit the covers that protects the oil screws, tightening torque, 30 Nm.



Notes

A series of horizontal dotted lines for writing notes, spanning the width of the page.

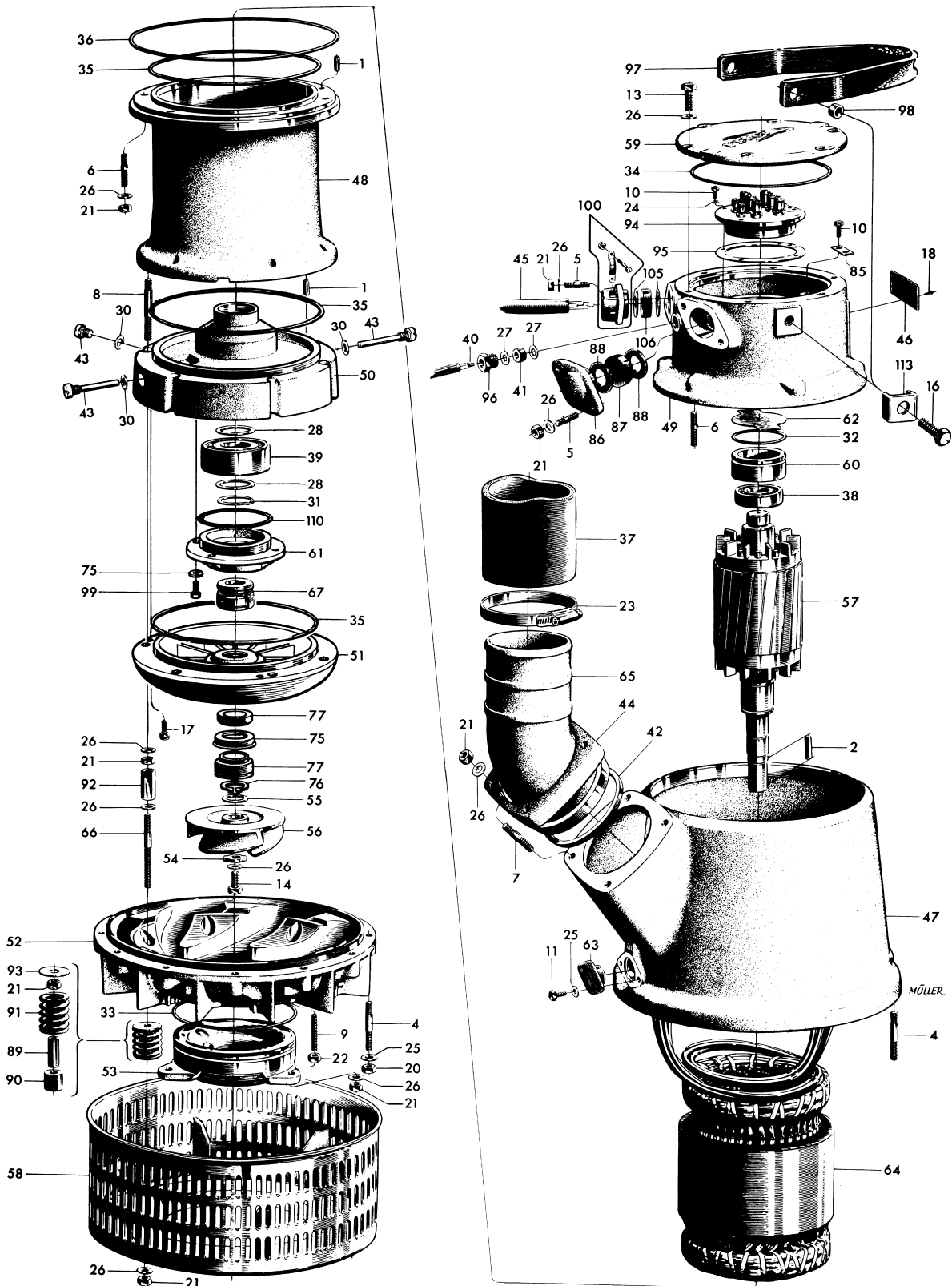

<i>Item No.</i>	<i>Denomination</i>	<i>Item No.</i>	<i>Denomination</i>
1	Grooved pin	52	Diffusor
2	Key	53	Suction cover
4	Stud M10x75	54	Washer, spec.
5	Stud M12x45	55	Washer
6	Stud M12x50	56	Impeller
7	Stud M12x55	57	Shaft-rotor unit
9	Stud M12x65	58	Strainer
10	Hexagon screw M8x20	59	Junction box cover
11	Hexagon screw M10x16	60	Bearing seat
13	Hexagon screw M12x35	61	Bearing cover
16	Hexagon screw M16x35	62	Washer
17	Socket head screw (M10x25)	63	Rubber cap
18	Screw	64	Stator
20	Hexagon nut M10	65	Connection
21	Hexagon nut M12	66	Stud, spec.
22	Hexagon nut M12	67	Inner seal
24	Washer	76	Retaining ring
25	Washer	77	Outer seal
26	Washer	85	Earthing washer
27	Washer	86	Cover
28	Washer	87	Rubber seal
30	Circlip	88	Washer
31	O-ring (19.2x3.0)	89	Pipe
32	O-ring (79.2x5.7)	90	Sleeve
33	O-ring (LT 199.3x5.7 HT 219.3x5.7)	91	Spring
34	O-ring (219.3x5.7)	92	Nut, spec.
35	O-ring (279.3x5.7)	93	Washer
36	O-ring (339.3x5.7)	94	Terminal board unit
38	Ball bearing SKF 6208RS1	95	Gasket
39	Ball bearing SKF 3311/C-3	96	Gland screw
40	Control cable	97	Handle
41	Seal sleeve	98	Sleeve
42	Gasket	99	Screw
44	Flange	100	Cable entry unit
45	Motor cable	113	Holder
46	Data plate	137	Hose
47	Outer casing	138	Hose clamp
48	Stator casing		
49	Bearing housing, upper		
50	Bearing housing, lower		
51	Oil casing		



www.flygt.com