



# Installation, care and maintenance

---

4630, 4640, 4650, 4660, 4670, 4680



# CONTENTS

This “Installation, Care and Maintenance” applies to the following versions of the 4600-series:

## 4630

4630.410, 4630.490,  
PP4630.410, PP4630.490

## 4640

4640.410, 4640.490,  
PP4640.410, PP4640.490

## 4650

4650.410, 4650.490,  
PP4650.410, PP4650.490

## 4660

4660.410, 4660.490,  
PP4660.410, PP4660.490

## 4670

4670.410, 4670.490,  
PP4670.410, PP4670.490

## 4680

4680.410, 4680.490,  
PP4680.410, PP4680.490

## Identification of safety and warning symbols



### General Danger:

Non-observance given to safety instructions in this manual, which could cause danger to life have been specifically highlighted with this general danger symbol.



### High Voltage:

The presence of a dangerous voltage is identified with this safety symbol.

	Page
<b>Guarantee</b> _____	3
<b>Data plates interpretation</b> _____	4
<b>Product description</b> _____	5
Applications _____	5
Motor data _____	6
Design _____	7
Materials _____	9
Weights _____	9
Performance curves for PP _____	10
<b>Transportation and storage</b> _____	11
<b>Installation</b> _____	11
Safety precautions _____	11
Handling equipment _____	11
Mixer installation alternatives _____	12
Flange mounted mixer _____	12
PP-pump installation _____	13
<b>Electrical connections</b> _____	15
CLS and FLS sensors _____	17

	Page
<b>Operation</b> _____	18
Before starting _____	18
During operation _____	18
<b>Care and maintenance</b> _____	19
Safety precautions _____	19
Service _____	19
Changing the oil _____	22
Replacing the propeller _____	23
Lifting device _____	24
<b>Tools and accessories</b> _____	25
Tools _____	25
Start and control equipment _____	25
Seal protection _____	25
Flush protection _____	25
Cutting rings _____	26
Cooling jacket _____	26
<b>Fault tracing (Troubleshooting)</b> _____	27
<b>Service log</b> _____	30

# NOTES FOR EXPLOSION APPROVED MACHINES

The explosion proof version (Ex-approved) is designed for use in explosive environments in accordance with approvals stated on page 4.



According to rules the Ex-approved machine must always work completely submerged in the liquid.



Thermal contacts must always be used on Ex-approved machine due to approval conditions.

All work on the explosion-proof motor section must be performed by personnel authorized by Flygt.

Flygt disclaims all responsibility for work done by untrained, unauthorized personnel.

## GUARANTEE

Flygt undertakes to remedy faults in products sold by Flygt provided:

- that the fault is due to defects in design, materials or workmanship;
- that the fault is reported to Flygt or Flygt's representative during the guarantee period;
- that the product is used only under conditions described in the care and maintenance instructions and in applications for which it is intended;
- that the monitoring equipment incorporated in the product is correctly connected;
- that all service and repair work is done by a workshop authorized by Flygt;
- that genuine Flygt parts are used.

Hence, the guarantee does not cover faults caused by deficient maintenance, improper installation, incorrectly executed repair work or normal wear and tear.

Flygt assumes no liability for bodily injuries, material damages or economic losses beyond what is stated above.

**Official approval applies only providing:**

- **that the product is used under condition described in the care and maintenance instructions and in applications for which it is intended;**
- **that the monitoring equipment incorporated in the product is correctly connected;**
- **that all service and repair work is done by a workshop authorized by Flygt;**
- **that genuine Flygt parts are used.**

Flygt guarantees that a spare parts stock will be kept for 15 years after the manufacture of this product has been discontinued.

The manufacturer reserves the right to alter performance, specification or design without notice.

# DATA PLATE INTERPRETATION

## GENERAL DATA PLATE

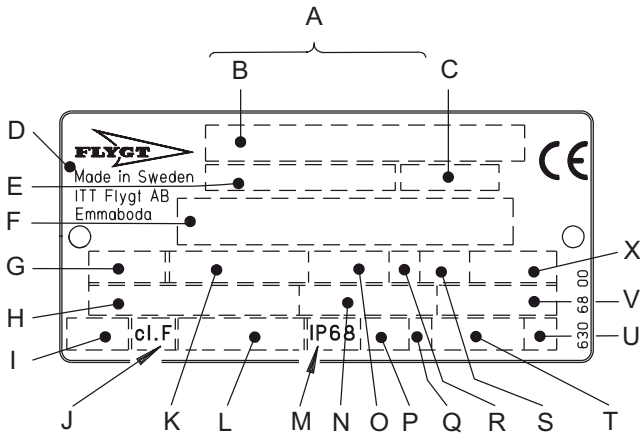

- A Serial number
- B Product code + Number
- C Curve code
- D Country of origin
- E Product number
- F Additional information
- G Phase; Type of current; Frequency
- H Rated voltage
- I Thermal protection
- J Thermal class
- K Rated shaft power
- L International standard
- M Degree of protection
- N Rated current
- O Rated speed
- P Max. submergence
- Q Direction of rotation: L=left, R=right
- R Duty class
- S Duty factor
- T Product weight
- U Locked rotor code letter
- V Power factor
- X Max. ambient temperature

## APPROVAL PLATES

*Always together with the general data plate.*

**EN:** European Norm,

ATEX Directive

EN 50014, EN 50018, EN 1127-1,

⊕ II 2 G EEx dIIB T4

⊕ I M2 EEx dl (only 4650 and 4660)

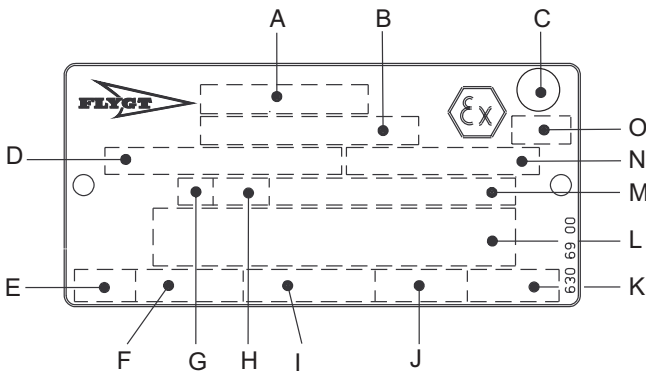

- A Approval
- B Approval authority + Approval Number
- C Approval for Class I,
- D Approved drive unit
- E Stall time
- F Starting current/Rated current
- G Duty class
- H Duty factor
- I Input power
- J Rated speed
- K Controller
- L Additional information
- M Max. ambient temperature
- N Serial Number
- O ATEX marking

**FM:** Factory Mutual,

Class I Div 1 Grp C and D

Class II Div 1 Grp E, F and G

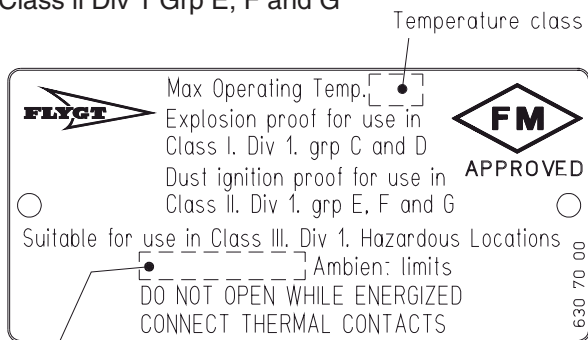

Max. ambient temperature

# PRODUCT DESCRIPTION

## General Description

**These care and maintenance instructions apply to both the standard version and the explosion proof version of the submersible Flygt mixers and PP-pumps.**

The explosion proof version (Ex-approved) is designed for use in explosive environments in accordance with the approvals, see page 4.

The submersible mixer and the PP-pump in the 4600-series have the below features:

- direct driven electric multipole motors.
- propellers with different diameters and blade angles.
- different materials.
- different seals.
- different installation modes.

**The pH of the liquid:** 1—12.

**Liquid temperature:** max. 40°C (105°F).

Warm liquid version max. 90°C (195°F).

**Depth of immersion:** max. 20 m (165 ft).



**Only Ex-approved machines may be used in explosive or flammable environments or for mixing/pumping flammable liquids.**

## Applications

For other applications than mentioned below, contact your nearest Flygt representative for information.

### Mixer

The mixer is intended to be used in:

- sewage plants, sludge tanks and aeration basins, anaerobic or oxygen saturated water, presence of rags etc.
- industrial processes, heavy environments with high demands of operational security, water with usually metallic salt, paper pulp and cellulose, food and chemical industry.
- industrial sewage processes, some wearing, presence of rags and metallic salt.
- mineral slurries with high wearing characteristics, presence of rags acceptable.
- fish farms and current creating in dams, oxygen supply, demands of environmental approved materials. Sweet, brackish or salt water.
- liquid manure, presence of straw, strings, board-pieces etc, floating sludge with a thickness of up to 1 meter (3.3 ft).

The mixer is designed for use in many different situations where high flow capacity in relation to power consumption is required.

The mixing effect is dependent upon the density and the viscosity of the liquid and on the volume/shape of the tank.

More than one mixer is required for larger tanks.

### Flange mounted mixer

The flange mounted mixer is intended to be used in:

- Oil industry/oil tanks.
- Pulp and paper industry.
- Various process industry.

### PP-pump

The PP-pump is intended to be used for:

- clean water pumping at land drainage,
- irrigation and controlling of water course systems,
- waste water treatment, recirculation within treatment processes or return sludge pumping.

The hydraulic parts together with the installation accessories are specially designed to optimize the performance of the pump.

## Motor data

Data for liquid max 40°C (105°F)

### 4630

50 Hz, 1.5 kW,  
3 phase, 8 pole,  
710\* r/min

Voltage V	Rated current A	Starting current A
200	8.3	27
220	9.1	30
230	7.2	23
380	4.4	14
400	4.2	14
415	4.0	13
500	3.3	11
1000 <sup>1)</sup>	2.0	6.2

60 Hz, 1.9 kW (2,5 hp),  
3 phase, 8 pole,  
855\*\*r/min

Voltage V	Rated current A	Starting current A
200	9.3	29
220	9.6	33
230	8.3	28
400	4.8	16
460	4.2	14
480	4.3	15
575	3.4	11
600	3.4	12

### 4640

50 Hz, 2.5 kW,  
3 phase, 8 pole,  
705\* r/min

Voltage V	Rated current A	Starting current A
200	14	45
220	15	51
230	12	39
380	7.4	24
400	6.5	20
415	6.5	22
500	5.5	18
1000 <sup>1)</sup>	3.1	10

60 Hz, 3.0 kW (4.0 hp),  
3 phase, 8 pole,  
855\*\*r/min

Voltage V	Rated current A	Starting current A
200	15	51
220	16	59
230	13	46
400	7.8	27
460	6.7	23
480	6.9	25
575	5.4	19
600	5.5	20

### 4650

50 Hz, 5.5 kW,  
3 phase, 12 pole,  
470\* r/min

Voltage V	Rated current A	Starting current A
200	32	88
220	30	105
230	31	90
400	17	48
415	16	47
500	13	37
1000 <sup>1)</sup>	7.3	22

60 Hz, 6.2 kW (8.3 hp),  
3 phase, 12 pole,  
575\*\* r/min

Voltage V	Rated current A	Starting current A
200	32	93
220	32	105
230	30	92
400	18	56
460	16	51
480	16	54
575	12	38
600	12	41

<sup>1)</sup> Not FM-approved    <sup>\*)</sup> 400 V    <sup>\*\*)</sup> 460 V

### 4660

50 Hz, 10 kW,  
3 phase, 12 pole,  
475\* r/min

Voltage V	Rated current A	Starting current A
200	55	148
220	56	170
230	48	136
380	32	95
400	29	87
415	30	92
500	23	67
1000 <sup>1)</sup>	13	41

60 Hz, 11.2 kW (15.0 hp),  
3 phase, 12 pole,  
575\*\* r/min

Voltage V	Rated current A	Starting current A
200	58	178
220	60	202
230	51	156
400	32	105
460	27	84
480	28	96
575	22	71
600	22	75

### 4670

50 Hz, 13 kW,  
3 phase, 16 pole,  
365\* r/min

Voltage V	Rated current A	Starting current A
200	89	234
230	81	216
400	44	117
415	44	118
500	36	94
550	32	85
690 <sup>1)</sup>	26	68
1000 <sup>1)</sup>	20	53

60 Hz, 14.9 kW (20 hp),  
3 phase, 16 pole,  
435\*\* r/min

Voltage V	Rated current A	Starting current A
200	98	260
220	90	238
230	86	229
400	50	133
460	48	127
480	46	121
575	34	91
600	36	97
1000 <sup>1)</sup>	20	53

### 4680

50 Hz, 25 kW,  
3 phase, 16 pole,  
365\* r/min

Voltage V	Rated current A	Starting current A
200	160	450
230	139	390
400	80	225
415	77	217
500	66	187
550	58	161
690 <sup>1)</sup>	46	129
1000 <sup>1)</sup>	35	100

60 Hz, 30 kW (40 hp),  
3 phase, 16 pole,  
435\*\* r/min

Voltage V	Rated current A	Starting current A
200	194	525
220	179	490
230	160	430
400	93	250
460	87	236
480	84	228
575	66	178
600	69	189
1000 <sup>1)</sup>	38	103

<sup>1)</sup> Not FM-approved    <sup>\*)</sup> 400 V    <sup>\*\*)</sup> 460 V

## Design

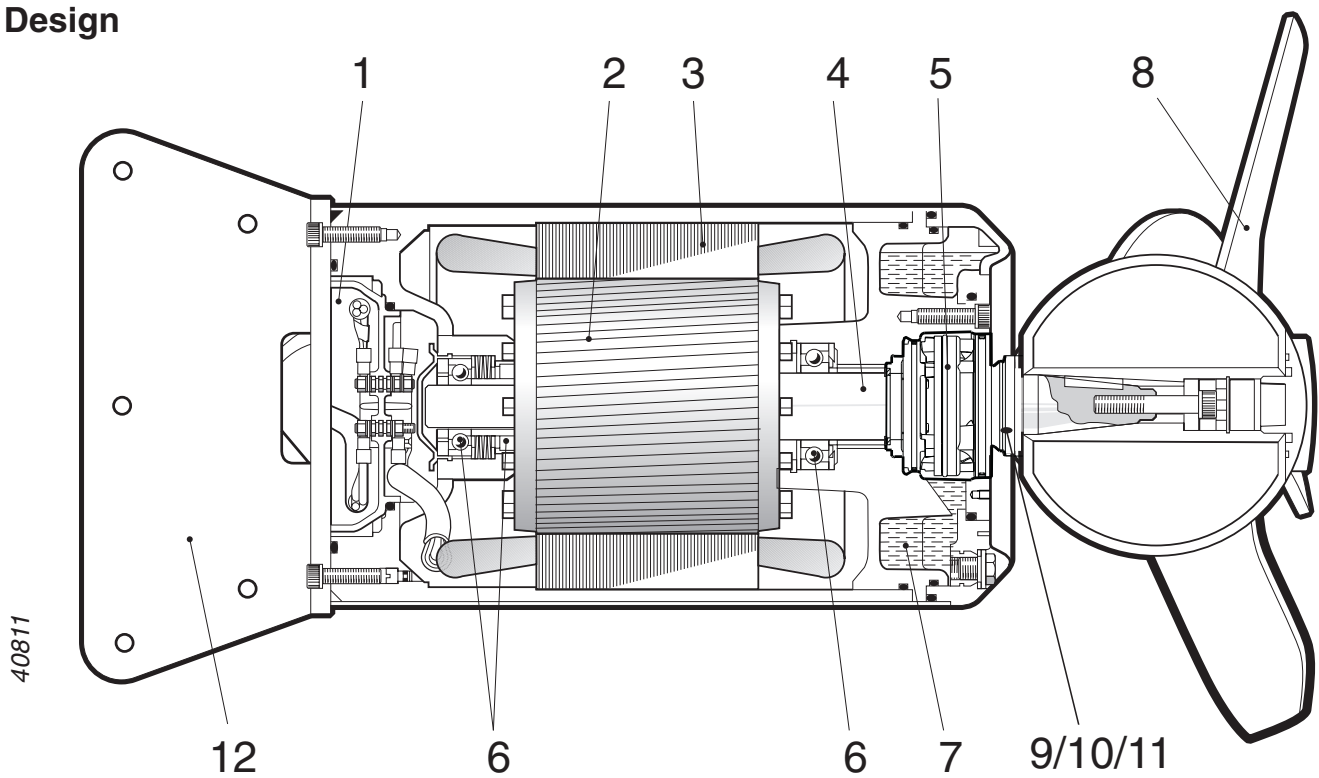

### Cable entry

The cable entry has two compressible rubber bushings to seal off and to relieve the cable.

### 1. Junction box

The junction box is completely sealed off from the surrounding liquid and the stator casing.

### 2. Motor

Squirrel-cage 3-phase induction motor for 50 Hz or 60 Hz.

The motor is started by means of direct on-line start.

The motor can be run continuously or intermittently with a maximum of 15 evenly spaced starts per hour.

The stator is insulated in accordance with class H (180°C, 355°F). The motor is designed to supply its rated output at  $\pm 5\%$  variation of the rated voltage. Without overheating the motor,  $\pm 10\%$  variation of the rated voltage can be accepted provided that the motor does not run continuously at full load. The motor is designed to operate with a voltage imbalance of up to 2% between the phases.

### 3. Monitoring equipment

The stator incorporates three thermal contacts connected in series.

The thermal contacts open at 125°C (260°F).

NOTE! The thermal contacts should be connected for liquid temperature up to 40°C (105°F) and **always** for Ex approved machines.

See also “Electrical connections” and separate instructions for starter equipment.

The machine can be equipped with sensors, CLS for sensing water in the oil and/or FLS for sensing water in the stator casing. The CLS sensor is not applicable for Ex-approved machines.

NOTE! 4630 and 4640 can only be equipped with FLS.

### 4. Shaft

The motor shaft is delivered with the rotor as an integral part.

The motor shaft is completely sealed and will not come in contact with the liquid.

### 5. Shaft seals

Mechanical face seals plug-in type, which combines an inner and an outer seal into one, rigid unit.

### 6. Bearings

The shaft is carried in one single-row angular contact ball bearing and a single-row cylindrical roller bearing together with a single-row angular contact ball bearing.

The bearings are dimensioned for more than 100 000 (L 10 aa) hours of operation.

### 7. Oil casing

The oil lubricates and cools the seals and acts as an additional barrier against penetrating liquid.

Pressure build-up within the oil casing is reduced by means of a built-in air volume.

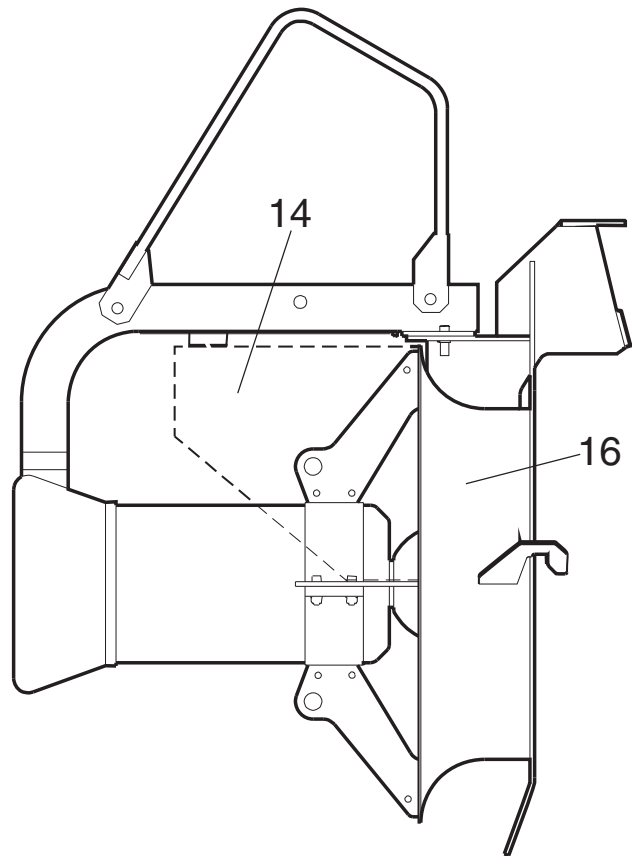
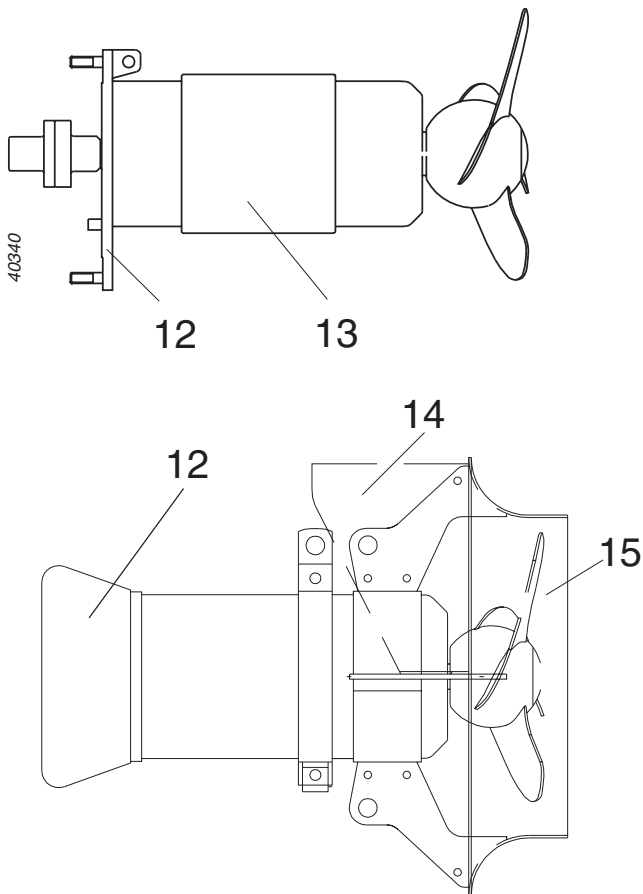

### 8. Propeller

The propeller is three-bladed and the blades have a large width and a thin profile, a smooth surface and are back-swept. This gives a highly efficient and clog-free operation.

The propeller angle can be adjusted to meet requirements. Angles between 4° and 19° are possible, but restricted upwards depending on version and applications due to available power.

### 9. Flush protection

The mixer and the PP-pump can be equipped with accessories for water or air flushing systems. Flushing the propeller hub area and the outer seal reduces the risk of sticking when mixing reactive slurries.

### 10. Cutting rings

The propeller can be equipped with cutting rings to prevent clogging of the hub area.

The cutting rings can be used with or without flushing. These are intended to be used for mixer applications, where liquids with long fibres are to be mixed.

### 11. Seal protector

The mixer and PP-pump can be equipped with seal protector to prevent clogging.

### 12. Fixing plate

The mixer is available with two types of fixing plate, one for guiding bar installation and one for flange mounted mixer.

### 13. Cooling jacket

Normally the stator is cooled by the surrounding liquid. External cooling (cooling jacket) is available as option.

### 14. Vortex protection shield

In order to avoid vortex the machine can be equipped with a protective shield.

### 15. Jet ring for mixer

The mixer can be operated with or without a jet ring. The jet ring improves the efficiency and directs the jet.

**NOTE. Operation without jet ring affects the power consumption.**

### 16. Inlet cone for PP-pump

The inlet cone is designed to give the best influence on the created flow .

### Discharge connection for PP-pump

The function of the discharge connection is to fix the inlet cone onto a pipe or a diffusor.

### Guiding equipment for PP-pump

The guiding equipment consists of two pipes (guide bars) and upper guide bar holders.

### Installation for PP-pump

The PP-pump should be installed horizontally on a wall and guided vertically along the wall.

The pump slides down along guide bars and connects automatically to the discharge connection. The flange of the inlet cone directs the pump at guiding and secures the correct position on the discharge connection.



## Materials

Denomination	Materials	Flygt No	EN	ASTM
Propeller	Stainless steel	0344.2343.02	1.4432	316L
	or Alloyed white iron (L102)	0314.0466.20	GLJ 250 A 532 (ALLOY IIIA)	
Major castings <sup>1</sup>	Cast iron	0314.0125.00	—	A48 No 35B
Shaft <sup>1</sup>	Stainless steel	0344.2303.05	1.4021	420
Oil housing, Propeller cover	Vynylester SMC CR30	0544.9585.70	—	—
Bearing casing 4630 and 4640	Aluminium	0404.4263.10	<b>DIN</b> 1725/68 <b>BS</b> 1490:70	B85A413.0 A1413.0 GD-AISI12
Coupling, Cooling jacket, Tubes	Stainless steel	0344.2343.02	1.4432	316L
O-rings, Gasket, Cable entry, Seal sleeve,	Nitrile rubber (NBR) 70°IRH (black)	0516.2637.04	—	—
	or Fluorinated-rubber (FPM) 70°IRH (green or black with a violet dot)	0516.2677.32	—	—
<b>Unic for mixer of General Purpose Stainless Steel (GP) ASTM 304</b>				
Jet ring, Fixing plate, Inlet cone, Lifting clamp	Stainless steel	0344.2333.02	1.4301	304
Lifting device, Support, Seal holder, Motor casing, Guiding rollers, Screws,	Stainless steel	0344.2343.02	1.4432	316L
<b>Unic for mixer of High Grade Stainless Steel (HP) ASTM 316</b>				
Jet ring, Fixing plate, Inlet cone, Lifting device, Support, Seal holder, Motor casing, Guiding rollers, Screws,	Stainless steel	0344.2343.02	1.4432	316L
<b>Unic for mixer of Proacid 254 (PA) ASTM S31254</b>				
Jet ring, Fixing plate <sup>2</sup> , Inlet cone, Lifting device, Support, Seal holder, Motor casing, Guiding rollers, Screws,	Proacid 254	0344.2378.02	1.4547	UNS S31254

### Mechanical face seals plug-in type:

Size	Inner seals	Outer seals	O-rings
4630, 4640	Csb/Al <sub>2</sub> O <sub>3</sub>	WCCR/Al <sub>2</sub> O <sub>3</sub>	NBR
	WCCR/Al <sub>2</sub> O <sub>3</sub>	WCCR/WCCR	FPM
	WCCR/Al <sub>2</sub> O <sub>3</sub>	RSiC/RSiC	FPM
4650 - 4680	Csb/WCCR	WCCR/WCCR	NBR
	WCCR/WCCR	WCCR/WCCR	FPM
	WCCR/WCCR	RSiC/RSiC	FPM
Csb	= Carbon		
Al <sub>2</sub> O <sub>3</sub>	= Aluminium oxid		
WCCR	= Corrosion resistant cemented carbide		
RSiC	= Silicon carbide		

<sup>1</sup>) Not exposed, <sup>2</sup>) Not for flange mounted mixer

## Weights

Max. weight of mixer and PP-pump irrespective of material, including lifting device but without motor cable is:

<b>4630</b>	Mixer without jet ring	55 kg ( 121 lb)
	Mixer with jet ring	60 kg ( 132 lb)
	Flange mounted mixer <sup>1</sup>	70 kg ( 154 lb)
	Cooling jacket <sup>2</sup>	3.3 kg ( 7.3 lb)
	PP-pump	77 kg ( 170 lb)
<b>4640</b>	Mixer without jet ring	60 kg ( 132 lb)
	Mixer with jet ring	70 kg ( 154 lb)
	Flange mounted mixer <sup>1</sup>	75 kg ( 165 lb)
	Cooling jacket <sup>2</sup>	3.3 kg ( 7.3 lb)
	PP-pump	85 kg ( 187 lb)
<b>4650</b>	Mixer without jet ring	150 kg ( 330 lb)
	Mixer with jet ring	175 kg ( 386 lb)
	Flange mounted mixer <sup>1</sup>	150 kg ( 331 lb)
	Cooling jacket <sup>2</sup>	7.5 kg ( 16.5 lb)
	PP-pump	204 kg ( 450 lb)
<b>4660</b>	Mixer without jet ring	190 kg ( 419 lb)
	Mixer with jet ring	220 kg ( 485 lb)
	Flange mounted mixer <sup>1</sup>	190 kg ( 419 lb)
	Cooling jacket <sup>2</sup>	7.5 kg ( 16.5 lb)
	PP-pump	251 kg ( 553 lb)
<b>4670</b>	Mixer without jet ring	285 kg ( 628 lb)
	Mixer with jet ring	350 kg ( 772 lb)
	Flange mounted mixer <sup>1</sup>	300 kg ( 661 lb)
	Cooling jacket <sup>2</sup>	11 kg ( 24 lb)
	PP-pump	410 kg ( 904 lb)
<b>4680</b>	Mixer without jet ring	405 kg ( 893 lb)
	Mixer with jet ring	470 kg ( 1036 lb)
	Flange mounted mixer <sup>1</sup>	415 kg ( 915 lb)
	Cooling jacket <sup>2</sup>	11 kg ( 24 lb)
	PP-pump	533 kg ( 1175 lb)

<sup>1</sup>) without jet ring and lifting device

<sup>2</sup>) not including tubes and couplings

# Performance curves for PP-pump

This curve shows the pump's performance. Diffusor or exit losses are not included. The system must therefore be considered in specific applications. If necessary contact Flygt's "Application engineers".

## 50 Hz PP4630, PP4640

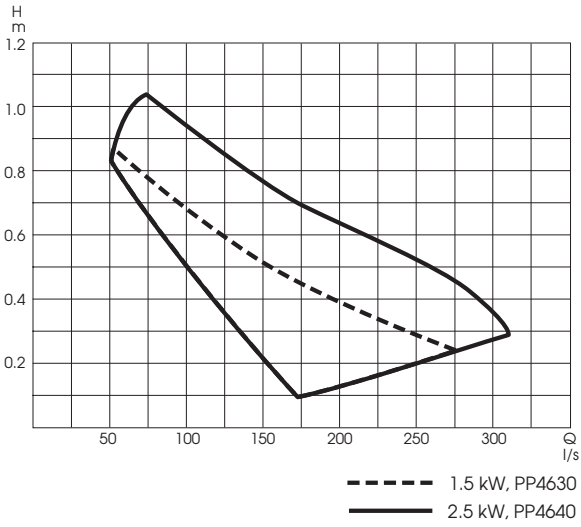

## 60 Hz PP4630, PP4640

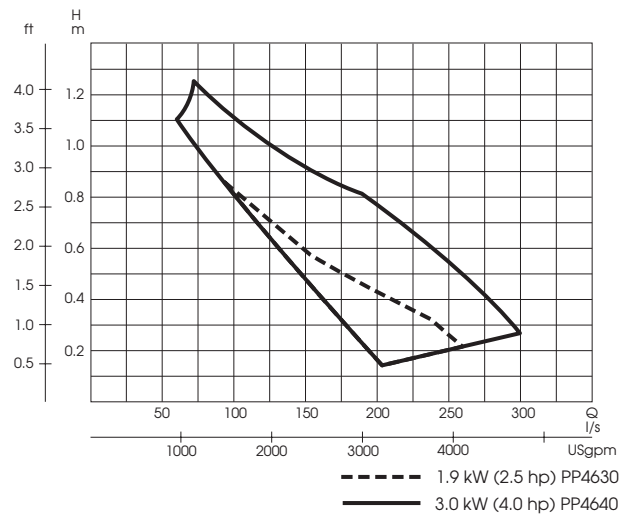

## 50 Hz PP4650, PP4660

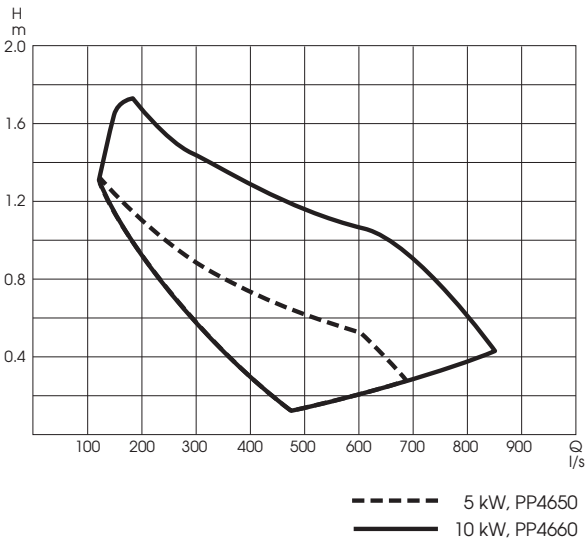

## 60 Hz PP4650, PP4660

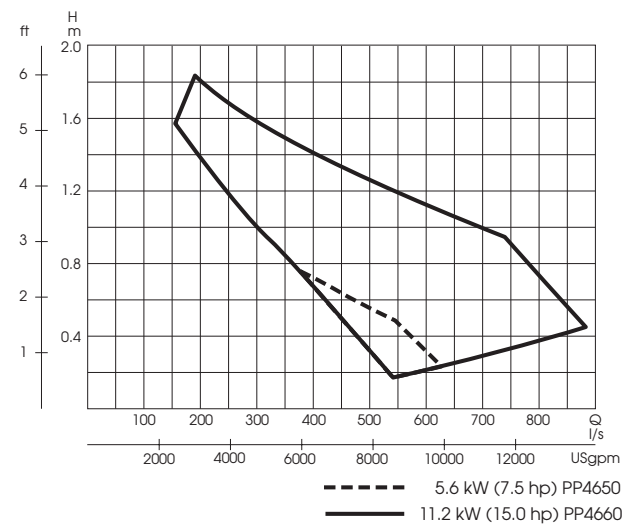

## 50 Hz PP4670, PP4680

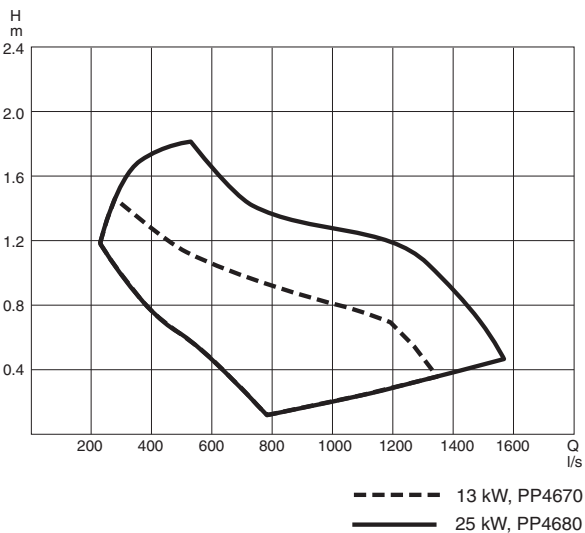

## 60 Hz PP4670, PP4680

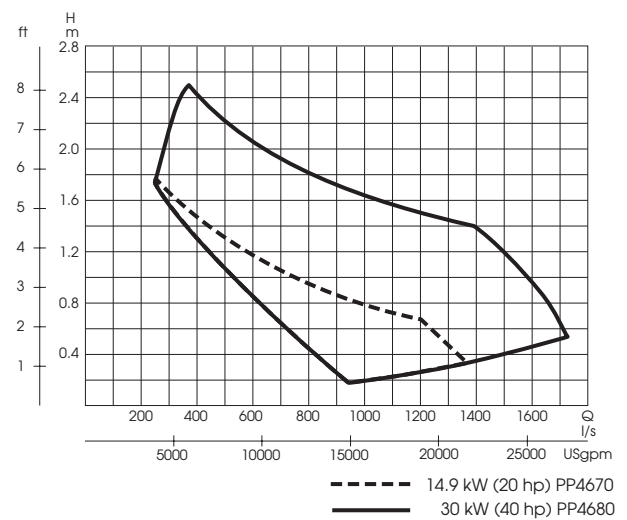

# TRANSPORTATION AND STORAGE

The mixer shall be transported and stored in a vertical or horizontal position. Make sure that it can't roll or fall over.



**Always lift the machine by the lifting device, never by the motor cable.**

For longer periods of storage, the mixer must be protected against moisture and heat. The propeller should be rotated by hand occasionally to prevent the seals from sticking together. If the mixer is stored for more than 6 months, this rotating is mandatory.

After a long period of storage, the mixer should be inspected before it is put into operation. Pay special attention to the seals and the cable entry.

# INSTALLATION



**Ex version!**  
**Installation of the explosion-proof mixer must be performed by authorized personnel.**

## Safety precautions

In order to minimize the risk of accidents in connection with the service and installation work, the following rules should be followed:

1. Never work alone. Use a lifting harness (part No. 84 33 02), a safety line (part No. 84 33 03) and a respirator (part No. 84 33 01), as required. Do not ignore the risk of drowning!
2. Make sure that there is sufficient oxygen and that there are no poisonous gases present.
3. Check the explosion risk before welding or using electric hand tools.
4. Do not ignore health hazards. Observe strict cleanliness.
5. Bear in mind the risk of electrical accidents.
6. Make sure that the lifting equipment is in good condition.
7. Provide a suitable barrier around the work area, for example a guard rail.
8. Make sure that you have a clear path of retreat!
9. Use a safety helmet, safety goggles and protective shoes/gloves.
10. All personnel who work with sewage systems should be vaccinated against diseases that can occur.
11. A first-aid kit must be handy.

Follow all other health and safety rules and local codes and practices.



**In order to avoid accidents, warning signs, for rotating propellers and machines that start automatically must be positioned visibly. The area in the proximity of the machines should be fenced off. For some installations and at certain operating points on the performance curve the noise level 70 dB or the noise level specified for the actual machine can be exceeded.**



**To reduce the risk of electric shock, see chapter "Installation" and "Electrical connections".**

**The tank of a sewage machine station must be vented in accordance with local plumbing codes.**

**The machine is not to be installed in locations classified as hazardous in accordance with the national electric code, ANSI/NFPA 70-1990.**

### CAUTION!

**This machine is intended to run fully submerged. Level sensing equipment should be installed if there is a possibility that the machine could be operated at less than the "minimum submergence depth" see chapter "Dimensions".**

## Handling equipment

Lifting equipment is required for handling the mixer.

The lifting device should not have a lifting capacity which is greater than twice the weight of the mixer.

Oversized lifting equipment could cause damage if the mixer gets stuck when being lifted.

Make sure that the lifting equipment is securely anchored.



**Always lift the machine by the lifting device, never by the motor cable.**

**Keep out from suspended loads.**

**Make sure that the machine can't roll or fall over and injure people or damage property.**

## Installation alternatives for mixers

Flygt supplies equipment for a method of installation which permits mixing over the horizontal and the vertical plane.

Avoid installations where:

- there are obstacles in front of the mixer,
- the flow on the suction side of the mixer is obstructed due to the design of the tank,
- the propeller can suck down air - vortex.

To avoid vortex use a vortex protective disc or place the mixer deeper in the liquid.

This is an absolute requirement for continuously operating mixers.

The mixer can be mounted on fixed structures, pillars, stands, gratings, on an anchored raft etc.

When installing, keep in mind the reaction force of the mixer, which can be up to, for:

4630	500 N
4640	900 N
4650	1800 N
4660	3000 N
4670	3900 N
4680	6600 N

### NOTE!

All welded joints must be pickled and polished before they come into contact with the liquid.

Run the cables so that they do not have any sharp bends and are not pinched.

NOTE! The end of the cable must not be submerged. Leads have to be above flood level, as water may penetrate through the cable into the junction box or the motor.

Consult your nearest Flygt representative regarding:

- choice of peripheral equipment.
- other problems in connection with installation.



In all installations, make sure that the motor cable cannot be drawn into the propeller.

Treat the cable as fragile, beware that no sharp bends occur throughout (during) installation procedure especially by entrance flange.

## Installation in horizontal or angle position on the guide bar

The mixer can be installed on the guide bar in horizontal position or with standard angle of  $c:a \pm 10^\circ$  or  $\pm 20^\circ$ . See Dimension drawings.

For other angle contact Flygt.

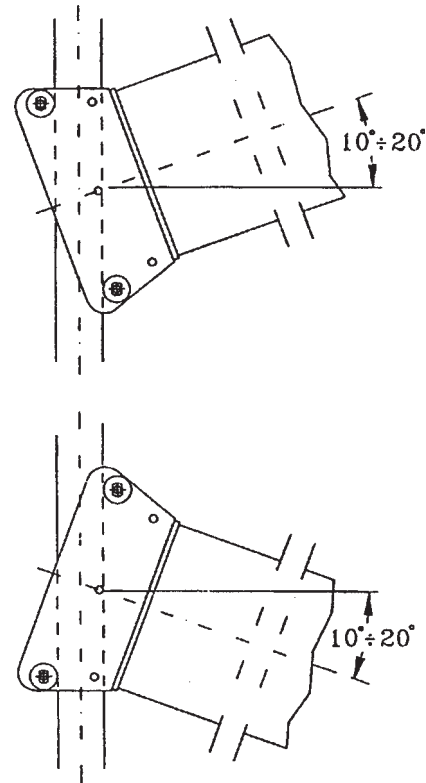

40315

Always test that the mixer will go easily up and down the guide bar, before the mixer has been lowered to the desired working depth.

### NOTE!

If the mixer is operated without jet ring there must be a stop function on the guide bar to avoid the propeller from being swung into the wall during operation.

### NOTE!

Don't position the mixer when it is operating.

## Flange mounted mixer

Flange mounted mixer is a unique method for installing mixers in tanks where guide bar or bottom stand installation is not the optimum solution. The mixer is assembled to a flange mounted cover by studs, nuts and a gasket. The flange mounted cover is calculated according to the Swedish standard TKN-87 (Tryckkärlnorm 1987), a standard for pressurised vessels. The flange mounted cover is made locally, contact your nearest Flygt representative for information.

## PP-pump installation

Mark out the location of the discharge connection on the wall.

Drill a hole in the wall (a little wider than the diameter of the tubes).

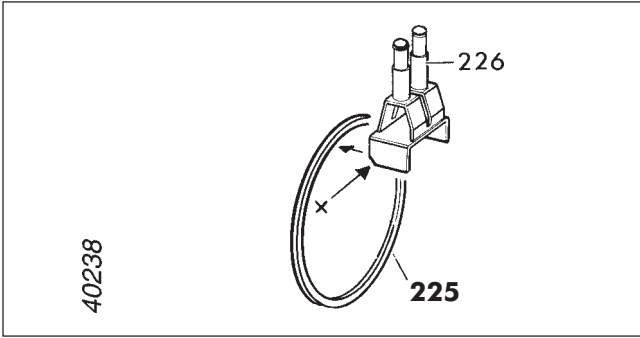

Weld together the bracket (226) and the ring (225).  
NOTE! Place the bracket with the sloping (x) towards the ring.

Centre the ring to the tube and weld the ring and bracket together with the tube.

### NOTE!

All welded joints must be pickled and polished before they come into contact with the liquid.

The tube must have a diameter A and a wall diameter B.

4630, 4640 A 406.4 mm (16") B 6.3 mm (0.25")

4650, 4660 A 609.6 mm (24") B 6.3 mm (0.25")

4670, 4680 A 812.8 mm (32") B 8.0 mm (0.31")

NOTE! It is important that the ring is welded perpendicular to the tube.

Place the unit in the wall.

Carefully measure the correct guide bar length. Cut the bars to the right length. The guide bars must have a diameter of 60.3 mm (2.37") and a wall thickness of 3.2 mm (0.13").

Place the guide bars on the bracket, don't forget the O-rings (200).

Put the guide holder unit (227) on the guide bars and mark the location of the guide holder on the wall.

Drill holes and tap in expansion bolts. Place the guide holder and guide bars in position, tighten the bolts.

Measure the centre-to-centre distance between the guide bars, which should be 100 mm.

It is important that the guide bars are mounted vertical, use a plumb line.

Tighten around the tube and check that the discharge connection will be fixed in the wall.

### 4630, 4640

AB Ø 406 (DIN2458 Ø 406.4 x 6.3)

C Ø 460

D 3.0

E 299

F 240

### 4650, 4660

AB Ø 610 (DIN2458 Ø 609.6 x 6.3)

C Ø 660

D 4.0

E 417

F 358

### 4670, 4680

AB Ø 813 (DIN2458 Ø 812.8 x 8.0)

C Ø 870

D 4.0

E 521

F 462

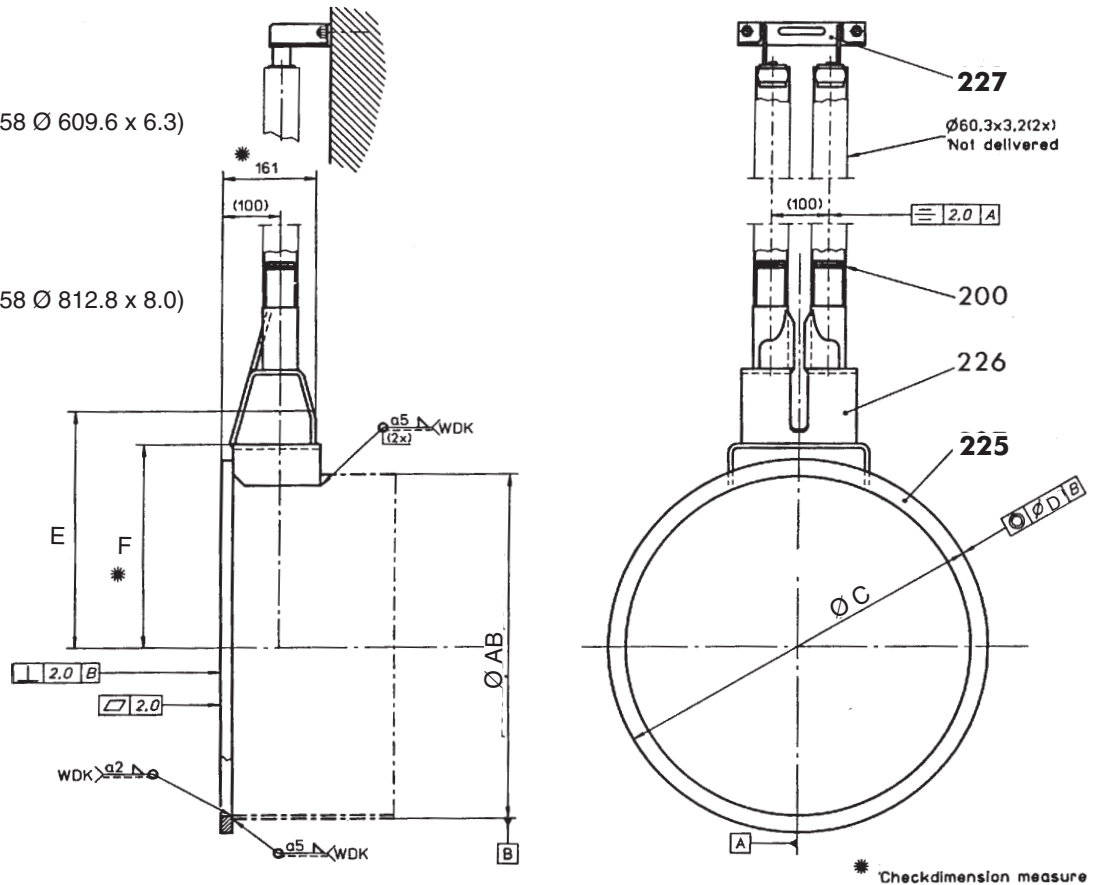

40279

**4630, 4640**

X = 330 mm, minimum

**4650, 4660**

X = 500 mm, minimum

**4670, 4680**

X = 650 mm, minimum

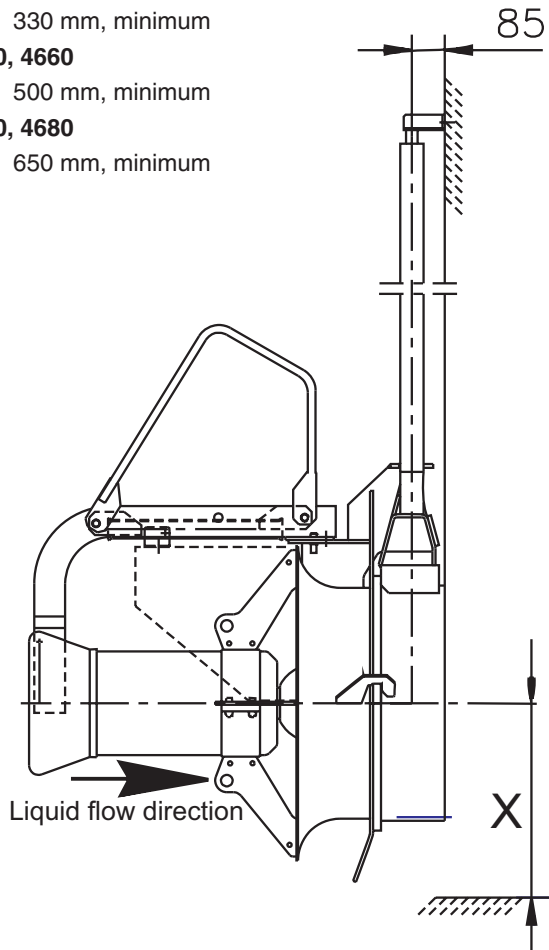

40254

Fit a hook on the lifting handle. Lift the pump so that it slips on to the guide bars.

Lower the pump so that the inlet cone hooks into the ring on the discharge connection.

Run the cables through tube so that they do not have any sharp bends and are not pinched.

NOTE! The end of the cable must not be submerged. Leads have to be above flood level, as water may penetrate through the cable into the junction box or the motor.



**In all installations, make sure that the motor cable cannot be drawn into the propeller.**

**The cables are fragile, beware that no sharp bends occur throughout (during) installation procedure especially by entrance flange.**

# ELECTRICAL CONNECTIONS



**Ex version!**  
**Electrical connections of the explosion-proof mixer must be performed by authorized personnel.**



**Before starting work on the machine, make sure that the machine is isolated from the power supply and cannot be energized.**

All electrical work shall be carried out under the supervision of an authorized electrician.

Local codes and regulations must be observed.



**All electrical equipment must be earthed (grounded). This applies to both the machine and any control or monitoring equipment.**

**Failure to heed this warning may cause a lethal accident. Make sure that the earth lead is correctly connected by testing it.**

**NOTE for Ex-approved machine**

**All work on the explosion-proof motor section must be performed by personnel authorized by Flygt.**

**Flygt disclaims all responsibility for work done by untrained, unauthorized personnel.**

Check that the voltage and frequency on the data plate are in accordance with your actual power supply.

The motor cannot be connected for different voltages. If intermittent operation is prescribed (see data plate), the mixer should be provided with control equipment that provides such operation.

Under no circumstances may the starting equipment be installed in direct connection with the tank.

To avoid leakage into the mixer check:

- that the cable entry seal sleeve and washers conform to the outside diameter of the cable. See the parts list.
- that the outer sheath on the cable is not damaged. When refitting a cable which has been used before, always cut off a short piece of the cable so that the cable entry sleeve does not seal onto the cable at the same position again.

Remember that the starting surge can be up to 3.5 times higher than the rated current. Make sure that the fuses or circuit breakers are of the proper amperage.

The table (see “Product Description”) gives rated current and starting current. Fuse amperage and cable must be selected in accordance with local rules and regulations.

The overload protection (motor protection breaker) shall be set to the motor’s rated current as given on the data plate.

With a clockwise phase sequence L1-L2-L3 (R-S-T), the propeller will rotate correctly, i.e. clockwise as viewed from the motor side. Check the phase sequence in the main (line) using a phase sequence indicator.

Three thermal contacts are incorporated in the stator and are normally closed. The thermal contacts can be connected to maximum of 250 volts, breaking at 4 amps. current at maximum.

Connect the thermal contacts to the starter.



**Thermal contacts must always be used on Ex-approved machine due to approval conditions.**

## Motor cable

### CAUTION!

**If the machine is intended for use with a Variable frequency Drive (VFD), be careful in choosing a motor cable. The VFD might require a screened cable.**

**Please, read the manufacturer’s instruction for the VFD.**

**If necessary, contact your ITT Flygt representative.**

Available motor cable are SUBCAB® or SUBCAB® AWG or a chemically resistant cable type HCR.

Connect the motor cable to the terminal board as illustrated in the figure “Direct on-line start”.

Connect the leads from the motor control circuit to T1 and T2.

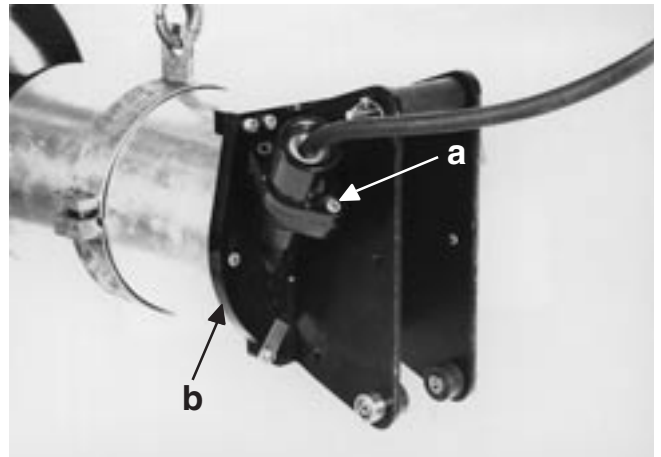

**Make sure the cable leads do not become trapped between the fixing plate and the stator casing (b).**

Tighten the screws (a) so that the cable entry unit forms an effective seal.

Connect the motor cable to the starter equipment. Check the direction of rotation, see “Before starting”.

If the direction of rotation is wrong, transpose two of the phase leads.

**NOTE! With long cables, the voltage drop must be taken into consideration, since the motor's rated voltage is the voltage measured at the terminal board in the machine.**

### Stator leads

Stator leads	Connection terminal board
Red	U1
Brown	V1
Yellow	W1

### Connection of the motor cable and the stator leads

Connect the motor cable and stator leads as shown in the wiring diagrams.

#### Cable

Conductors	Connection starter	Connection terminal board
------------	--------------------	---------------------------

#### SUBCAB® 4Gx

Brown	L1	U1
Blue	L2	W1
Black	L3	V1
Yellow/Green	Earth	Earth
Black T1	T1*	T1*
Black T2	T2*	T2*

#### SUBCAB® xAWG/7

Red	L1	U1
White	L2	W1
Black	L3	V1
Yellow	GC**	GC**
Yellow/Green	Earth	Earth
Orange	T1*	T1*
Blue	T2*	T2*

#### HCR SO7E6E5-7

Black 1	L1	U1
Black 2	L2	W1
Black 3	L3	V1
Black 4	T1*	T1*
Black 5	T2*	T2*
Black 6	-	-
Yellow/Green	Earth	Earth

\* Terminal for connection of terminal contacts in motor and monitoring equipment.

\*\* GC = Ground Check



**For safety reasons, the earth lead should be longer than the phase leads. If the motor cable is jerked loose by mistake the earth lead should be the last to come loose from its terminal. This applies to both ends of the cable.**

**Make sure that the mixer is correctly earthed (grounded).**

#### Direct on line start

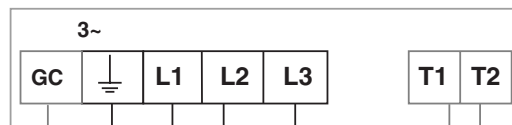

#### Y - Connection 4630 - 4640

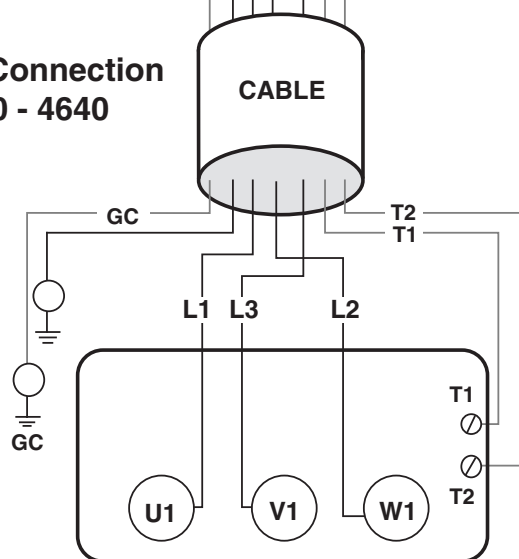

#### Direct on line start

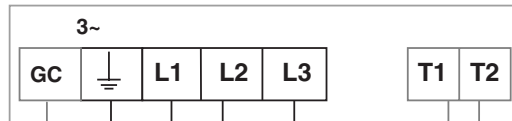

#### Y - Connection 4650 - 4660

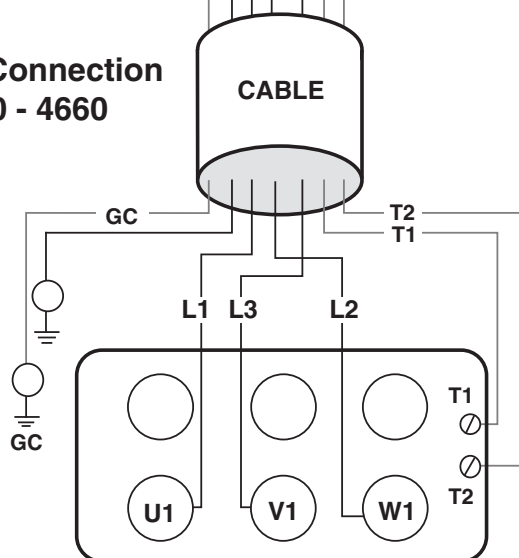



## Stator leads

Stator leads	Connection terminal board
Red	U1
Brown	V1
Yellow	W1
Green	U2
Blue	V2
Black	W2

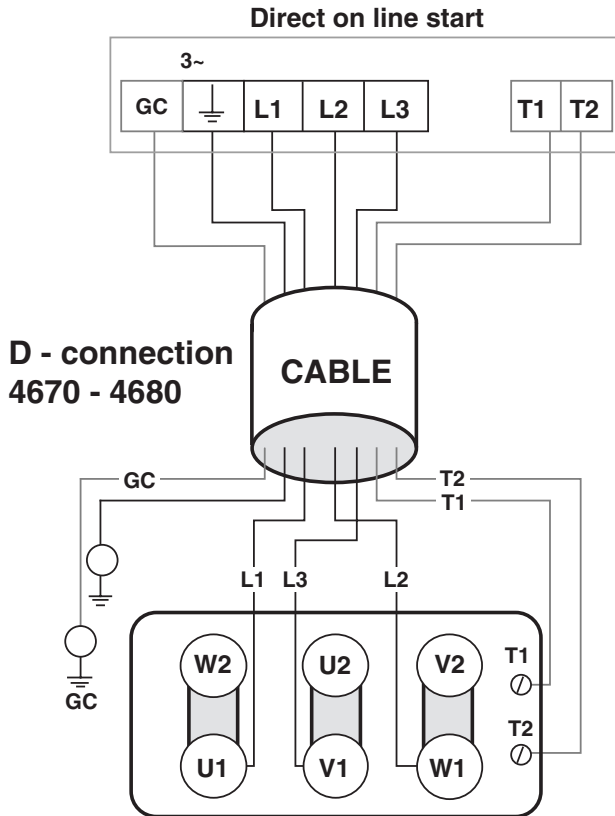

If persons are likely to come into physical contact with the machine or mixed/pumped media (liquid), e.g. on farms etc, the earthed (grounded) socket must have an additional earth-(ground-) fault protection device (GFI) connected.

When mixing/pumping near a lake (jetties, beaches and ponds etc) a safety distance of at least 20 meters (65 ft) between the person and the machine is necessary. The machine must never be placed directly into a swimming pool. If used in connection with swimming pools, special safety regulations apply.

## Monitoring equipment



Make sure that the monitoring equipment incorporated in the product is correctly connected.

### Capacitive leakage sensor CLS-30 and leakage sensor FLS (built in version).

The machine is available with leakage sensors for sensing water in the oil and/or the stator casing.

A plate in the junction box shows that the machine is equipped with sensors.

**CLS-30** is a leakage sensor for sensing water in the oil casing and issues an alarm when the oil contains 30% water. Oil change is recommended within 14 days of alarm. If the sensor issues an alarm shortly after the oil is changed, contact your nearest Flygt representative.

The CLS-30 sensor is installed in the bearing housing and goes down into the oil casing. Available for 4650 to 4680. The CLS-30 sensor is not applicable to Ex-approved machines.



Observe that the CLS cover is made of glass and can cause personal damage.

The **FLS** sensor consists of a small float switch for sensing water in the stator casing.

The FLS sensor is installed in the bottom of the stator casing.

The two sensors, CLS-30 and FLS, can be used in the same machine. They are connected in parallel. Follow the instruction for monitoring equipment.

# OPERATION

## Before starting

Check that the oil level minimum reaches up to the centrumline of the shaft.

Remove the fuses or open the circuit breaker and check that the propeller can be rotated by hand.

Check that the cable entry is securely tightened.

Check that the monitoring equipment (if any) works.

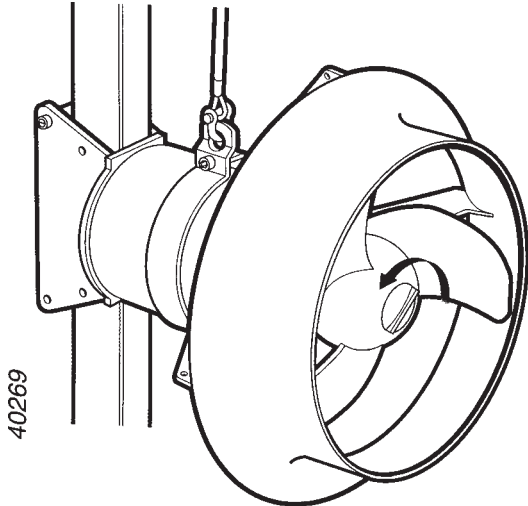

Check the direction of rotation. See the figure. The propeller should rotate clockwise, as viewed from the motor side.

The machine must be fixed to the guide bar during test starting.



**Watch out for the propeller and for the starting jerk, which can be powerful.**

## During operation of mixer



**Watch out for the propeller in rotation.**

The mixer is intended to operate with or without jet ring, due to its main application area. Operating without jet ring means that strict carefulness must be observed at test starting and in operation.

Test-run the mixer and note the current surge during start-up. At the instant of starting, it is normal for the current to exceed the operating current by 10—20 % for a few seconds. The steady-state current should be less than the rated current.

Excessive current consumption may be caused by high viscosity or density of the liquid or an improperly adjusted mixer.

Check accurately that the mixer does not vibrate. Vibration can occur when mixing is too vigorous in a small tank volume, or when the inflow or outflow of

liquid is impaired, by unbalanced propellers or by air sucked down by the propeller.

Vibration can also occur due to interference between several mixers.

For another operating direction for the mixer, contact ITT Flygt.

In continuous operation, air must not be drawn down by the propeller (a vortex must not form).

**NOTE! In order to avoid overheating the machine, it must always work completely submerged in the liquid.**

## During operation of PP-pump

Test-run the pump and note the current surge during start-up. At the instant of starting, it is normal for the current to exceed the operating current by 10—20 % for a few seconds. The steady-state current should be less than the rated current.

Excessive power consumption may be caused by:

- too high head
- wrong rotation
- high viscosity or density
- clogged or badly shaped propeller
- an improperly adjusted pump
- incorrect blade angle
- changing gap between propeller and inlet cone (due to damaged cone)

Low power might be caused by:

- vortex formation
- low head
- incorrect blade angle
- changing gap between propeller and inlet cone (due to damaged cone)

Check that the flow is non-violent and that the pump does not vibrate.

Vibration can occur due to:

- damaged propeller
- clogged propeller
- air suction through surface - vortex
- disturbance from other pumps, uneven attacking flow or too high head
- changing gap between propeller and inlet cone (due to damaged cone)

Tendency to clog can easily be observed by means of an apere.

In continuous operation, air must not be drawn down by the propeller (a vortex must not form).

**NOTE! In order to avoid overheating the machine, it must always work completely submerged in the liquid.**

# CARE AND MAINTENANCE

## Safety precautions



**Before starting work on the machine, make sure that the machine is isolated from the power supply and cannot be energized.**

**This applies to the control circuit as well.**

To prevent injury watch out for damaged and worn parts.

NOTE! This applies to the control circuit as well.

The following points are important in connection with work on the machine:

- make sure that the machine has been thoroughly cleaned.
- observe good personal hygiene.
- beware of risk of infection.
- follow local safety regulations.

The mixer is designed for use in liquids which can be hazardous to health. In order to prevent injury to the eyes and skin, observe the following points when working on the machine:

- Always wear goggles and rubber gloves.
- Rinse the mixer thoroughly with clean water before starting work.
- Rinse the components in water after disassembly.
- Hold a rag over the oil casing screw (124) when removing it. Otherwise, pressure that may have built up in the mixer due to leakage of liquid into the mixer may cause splatter into the eyes or onto the skin.

Proceed as follows if you get hazardous chemicals in your eyes:

- rinse immediately in running water for 15 minutes. Hold your eyelids apart with your fingers.
- contact an eye doctor.

on your skin:

- remove contaminated clothes.
- wash skin with soap and water.
- seek medical attention if required.



**Make sure that the machine (or parts of the machine) can't roll or fall over and damage people or property.**

**In some installations the machine surface and the surrounding liquid may be hot. Bear in mind the risk of burn injuries.**

## Service



**Ex-version!**

**All work on the explosion-proof motor section must be performed by personnel authorized by Flygt.**

### Inspections and service intervals

Regular inspection and preventive maintenance ensure more reliable operation. The maintenance schedule below gives the recommended period of time when the machine should pass inspection and major overhaul.

The maintenance schedule is divided into two groups A and B depending on wearing and temperature.

Group	Wearing/Temperature	Inspection	Major overhaul
A	<ul style="list-style-type: none"> <li>• None or moderate/ 40°C (104°F)</li> </ul>	Every 8000 hours or once a year	Once every five years or every 50 000 hours
B	<ul style="list-style-type: none"> <li>• None or moderate/ 40°C - 90°C (104°F-194°F)</li> <li>• Heavy 40°C (104°F)</li> <li>• Csb inner seal</li> </ul>	Every 4000 hours or twice a year	Once every two years or every 20 000 hours or when inspect. indicates.

Major overhaul of the mixer should be made in a service workshop.

Tendency to clog can easily be observed by means of an amperemeter.

NOTE! Check the propeller. If the propeller is hard worn to uneven leading edge, the motor can be overloaded, because of clogging.

### Inspection

Inspection involves that following will be checked and measured if required;

- replacement of all worn components.
- check all screw connections.
- check quantity and condition of the oil.
- check if there is liquid in the stator casing.
- check the cable entry and condition of the cable.
- functional check of the start equipment.
- functional check of monitoring equipment.
- check of direction of rotation.
- check the lifting device and guide bars (clearance and wear).
- check of electrical insulation.
- replace all O-rings which are removed for inspection.
- check and rinse the space around the seals. See also "Recommended inspection"

### Major overhaul

This requires special tools and should be done by an authorized service shop. Workshop overhaul involves in addition to the inspection, that the following will be measured;

- replacement of bearing.
- replacement of the plug-in seal..
- replacement of oil.
- replacement of O-rings.
- replacement of seals in cable entry and moving the entry position of the cable.
- replacement of cable.

### Service contract

Flygt or its agent normally offers service agreements in accordance with a preventive maintenance plan. For further information, please contact your Flygt representative.



#### Ex-approved machine!

All work on the explosion-proof motor section must be performed by personnel authorized by Flygt.

## Recommended inspections

Inspection of	Action
Visible parts on mixer and installation	Replace or fix worn and damaged parts. Make sure that all screws, bolts and nuts are tight. Check the condition of lifting device/lifting eyes, chains and wire ropes. Check that the guide bar is vertical. Replace worn parts if they impair function.

Oil quantity



**WARNING.** If the seal leaks, the oil casing may be under pressure. Hold a rag over the oil casing screw in order to prevent splatter. See “Safety precautions” for additional information.

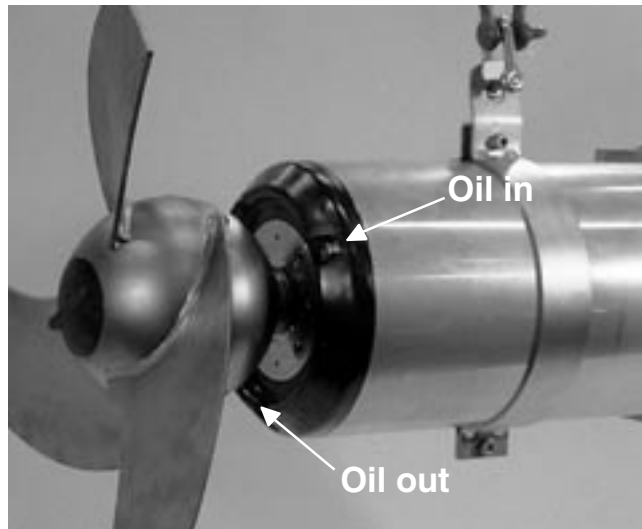

Check that the oil level minimum reaches up to the centrumline of the shaft. A check of the condition of the oil can show whether there has been an increased leakage. Check the oil by removing the oil drainage screw. Leave the oil filling screw in place in order to restrict the flow. As the oil separates the water, the liquid coming out first will indicate a possible leakage. Tap until clear oil is coming out. If leakage less than 0.1 ml/h, the seal functions normally. Refill the tapped volume with new oil. See “Changing the oil”.  
If the leakage is more than 0.1 ml/h, refill the oil. Run the mixer for one week and check the oil again. If leakage is more than 0.1 ml/h the fault may be:  
— that the outer mechanical seal is damaged. Contact a Flygt service shop.

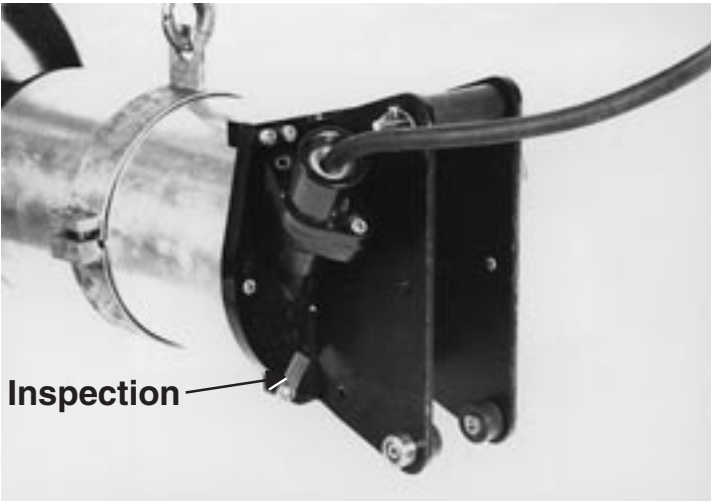
Inspection of	Action
Liquid in the stator casing	<p><b>WARNING.</b> If there has been leakage, the stator casing may be under pressure. Hold a rag over the inspection screw to prevent splatter. See “Safety precautions” for additional information.</p> <p>Only Ex-approved machines; remove the screw and the angle bracket. Remove the counter socket screw marked “INSP” and the O-ring. Remove the inspection plug and the O-ring. Be careful not to damage the O-ring. Tilt the machine so that any liquid in the stator casing can run out through the hole. If there is liquid in the stator casing:</p> <ul style="list-style-type: none"> <li>— check that the inspection plug is sufficiently tight.</li> <li>— check if the cable entry is leaking.</li> <li>— check if there is water in oil.</li> </ul> <p>Check stator inspection plug again after one week. If the stator casing contains liquid again, the fault may be:</p> <ul style="list-style-type: none"> <li>— that the inner seal is damaged.</li> </ul> <p>Contact a Flygt service shop.</p>
	Cable entry
	<p>Make sure that the cable entry is tight.</p> <p>If the cable entry leaks:</p> <ul style="list-style-type: none"> <li>— check that the entry is tightened and forms an effective seal.</li> <li>— cut a piece of the cable off so that the seal sleeves seals onto a new position on the cable.</li> <li>— replace the seal sleeves.</li> <li>— check that the gasket, seal sleeves and the washers, conform to the outside diameter of the cable.</li> </ul>
Cable	<p>Replace the cable if the outer sheath is damaged.</p> <p>Make sure that the cables do not have any sharp bends and are not pinched.</p>
Starter equipment	<p>If the starter equipment is faulty, contact an electrician.</p>
Monitoring equipment (should be checked often)	<p>Follow the instructions for monitoring equipment.</p> <p>Check:</p> <ul style="list-style-type: none"> <li>— signals and tripping function.</li> <li>— that relays, lamps, fuses and connections are intact.</li> </ul> <p>Replace defective equipment.</p>
Rotation direction of mixer (requires voltage)	<p>Transpose two phase leads if the propeller does not rotate clockwise as viewed from the motor side. Rotation in the wrong direction reduces the capacity of the mixer and the motor may be overloaded. Check the direction of rotation every time the mixer is reconnected.</p>
Insulation resistance in the stator	<p>Use insulation tester. With a 1000 V-DC megger the insulation between the phases and between any phase and earth (ground) should <b>not be less</b> than 1 MΩ.</p>

## Changing the oil

### Oil drainage

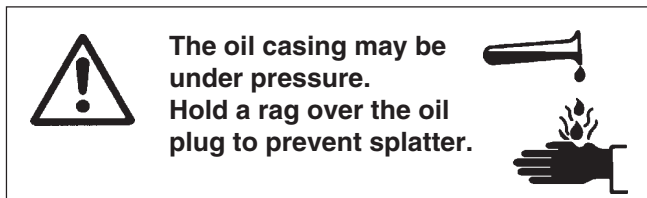

Lay the mixer over two supports or suspend the mixer horizontally from an overhead crane.

Keep a container underneath the screw to catch the oil when the screw is removed.



Unscrew the oil draining screw. It is easier to drain the oil if the oil filling hole screw is also removed. Hold the mixer over a vessel and allow the oil to run out. Put the oil casing screw back.

### Oil refill



Fill up with new oil in the oil filling hole, the mixer should be in a horizontal position. Always replace the O-rings (24) of the oil hole screws. Put the screws back and tighten them. Tightening torque 10—20 Nm (7.4—15 ft lb).

Recommended oil quantities for mixers positioned at 0° to ± 20° from the horizontal axis:

4630, 4640	0.35 litres
4650, 4660	1.0 litres
4670, 4680	2.4 litres

If the mixer will be positioned –90° downwards the recommended oil volume must be increased to:

4630, 4640	0.55 litres
4650, 4660	1.5 litres
4670, 4680	3.8 litres

### Flange mounted mixer

If the mixer is equipped with external oil change, pipes and couplings are connected between the oil casing and the fixing plate.

The fixing plate is provided with five threaded holes ISO G-3/8 for inspection and change of oil, cooling water and seal flushing.

For easy handling, equip the oil inspection holes with hydraulic couplings. Connect the male couplings to *Oil in* and *Oil out*. Drain the oil into an oil vessel.

Connect an oil gun to *Oil out* hydraulic coupling. Pump the oil until oil comes out from *Oil in* hydraulic coupling. Disconnect the male couplings from *Oil out* and *Oil in*. Put back the oil plugs.

The machine is delivered from factory with a tasteless and odourless paraffin oil suitable for raw or clean-water applications.

This oil is authorized according to FDA 172.878, (FDA = Food and Drug Administration authority in US).

We recommended that Mobil Whiterex or Shell Ondina, with viscosity class ISO VG15 to 32, be used.

In media where paraffin oil is not required, a mineral oil, i.e. compressor oil or hydraulic oil with (the same) viscosity class VG15 to 32, should be used. Regular motor oil, e.g. SAE 5(W) up to SAE 25(W) can also be used.

## Replacing the propeller

### Removing the propeller

**WARNING!** A worn propeller often has very sharp edges.



Remove the protective cover and the O-ring.  
Insert an M8 Allen key into the hub screw and loosen the propeller screw.  
When the screw has been unthreaded, puller operation is obtained through the head of the screw pressing the propeller outwards.  
Lift off the propeller.

### Installing the propeller

**NOTE!** If the machine will be equipped with flush protection and/or cutting rings, this must be installed before the propeller.

Make sure that the end of the shaft is clean and free of burrs. Polish off any flaws with fine emery cloth. Grease the end of the shaft and the propeller hub.

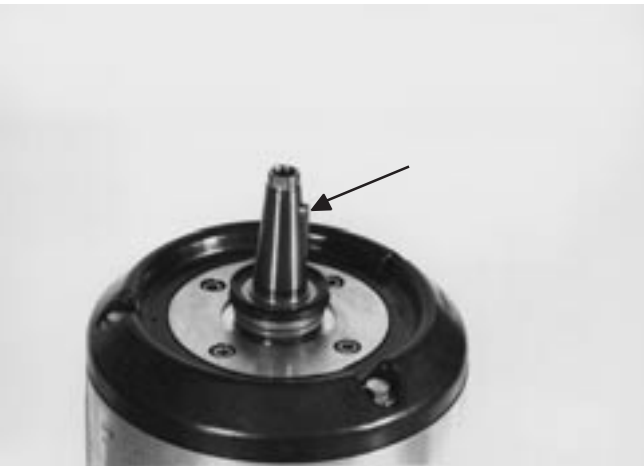

Check:

- that the parallel key is seated in the key way on the shaft.
- that the seal ring is correctly positioned.



Lift the propeller onto the shaft.

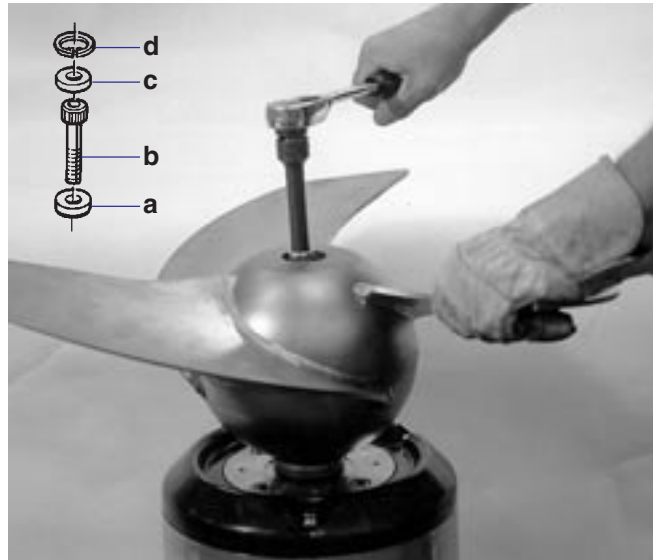

If the washers and propeller screw already are assembled, all you need to do is tighten the propeller screw.

If not, place the washer (a) onto the propeller screw (b). Fit the propeller screw. Mount the other washer (c) and secured it by a circlip (d).

Tightening torque for:

4630, 4640	40 Nm	(30 ft lb)
4650, 4660	136 Nm	(100 ft lb)
4670, 4680	197 Nm	(145 ft lb)

Fit the O-ring and mount the protect cover.

Check that the propeller can be rotated by hand.

## Lifting device and jet ring

Tightening torque for all the socket head screws are for 4630–4640 22 Nm (16 ft lb) and for 4650–4680 44 Nm (33 ft lb). Screw threads shall be lubricated with grease (90 18 00) before assembly.

(M8 = 22 Nm, M10 = 44 Nm).

Tighten the screws alternately.

### Lifting device with or without support

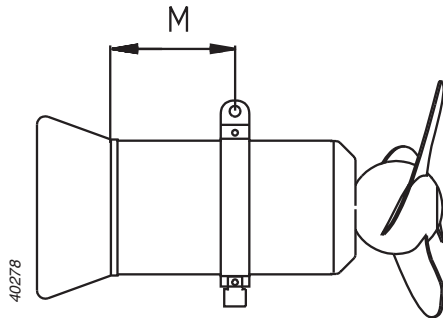

M = see Dimension drawings.

### Lifting device and jet ring with or without support

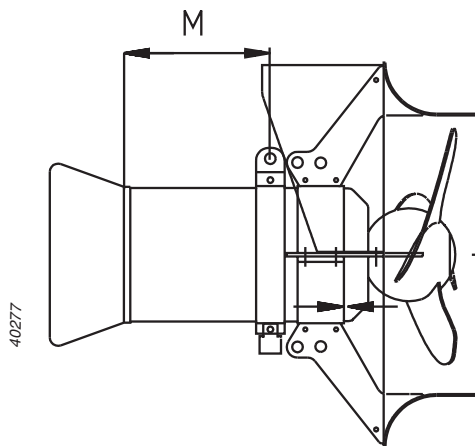

M = see Dimension drawings.

Mount the jet ring in line with the oil casing face.  
Check clearance between propeller and ring. (Rotate the propeller by hand.)

### Lifting device and inlet cone for PP-pump

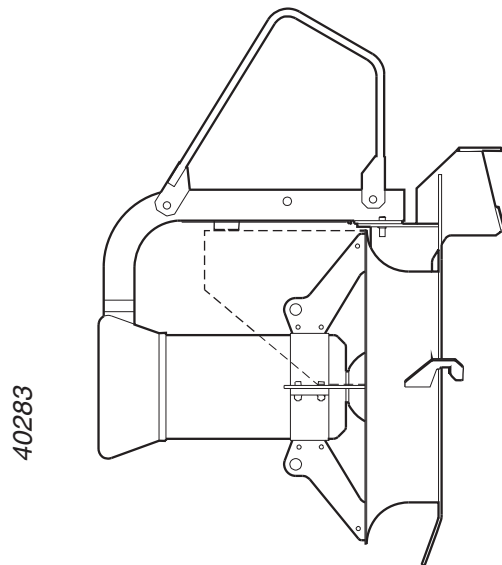

Check clearance between propeller and inlet cone.  
(Rotate the propeller by hand.)



# TOOLS AND ACCESSORIES

## Tools

Besides standard tools, the following tools are required in order to perform the necessary care and maintenance of the mixer:

Part No.	Description
84 15 66	Torque wrench 0—137 Nm (0—101 ft lb)
84 15 64	Torque wrench 50—225 Nm (37—166 ft lb)

For further information on tools, see Flygt's Tool Catalogue.

## Start and control equipment

Flygt has suitable starting and control equipment for the mixer. Contact Flygt for further information.

## Seal protection

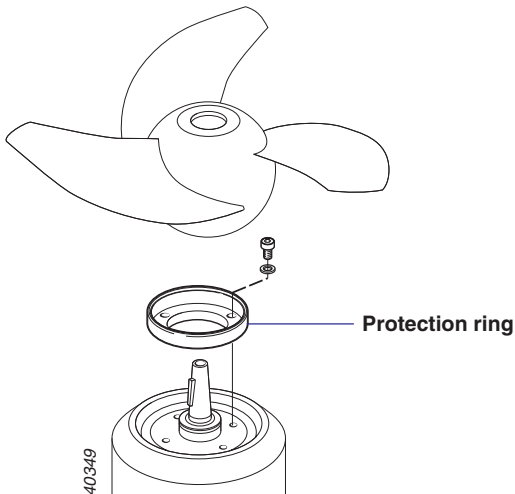

Fit the protective ring with the 4 washers and screws. Tightening torque 6—8 Nm.

The protecting ring must not be used in liquid with temperature exceeding 40°C (105°F).

## Flush protection

### Installing of flushing device

NOTE. Install the flushing device before the propeller. Mount the tube in the cover.

Fit the O-ring and the seal ring.

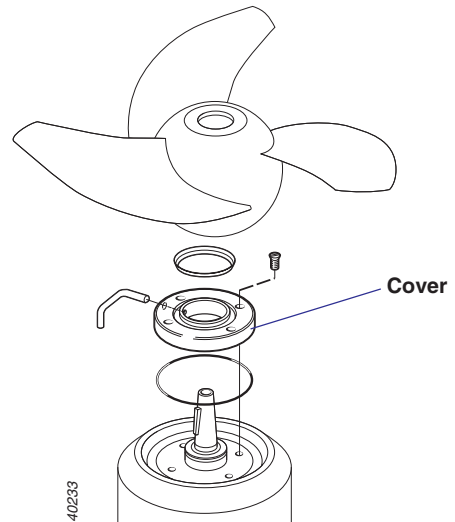

Mount the unit.

Tighten the screws. Tightening torque 6—8 Nm.

Connect a hose, an armoured hose size 1/4" is recommended for flushing.

### Flushing media/volume

The flush protected propeller hub can be flushed with air, water or other suitable media.

Recommended minimum/maximum flow for continuous flushing is:

	Flow media	Flow l/min	
		min.	max.
4630,4640	Water	0.5	—
	Air	10	20
4650,4660	Water	0.8	—
	Air	30	60
4670,4680	Water	1	—
	Air	50	100

It is important for the result to keep the minimum flow. Use a flow regulator.

For more information please contact Flygt.

## Cutting rings

### Assembling of cutting rings

Center the rotatory cutting ring over the propeller hub.

Use the cutting ring as a jig and drill 4 or 8 holes  $\varnothing$  4.9 mm, for the rivets.

Fix the cutting ring with the rivets.

If the machine will work with seal flushing, fit the tube in the stationary cutting ring.

Assemble O-ring, stationary cutting ring and fix the ring with the 4 screws.

Tightening torque 6—8 Nm.

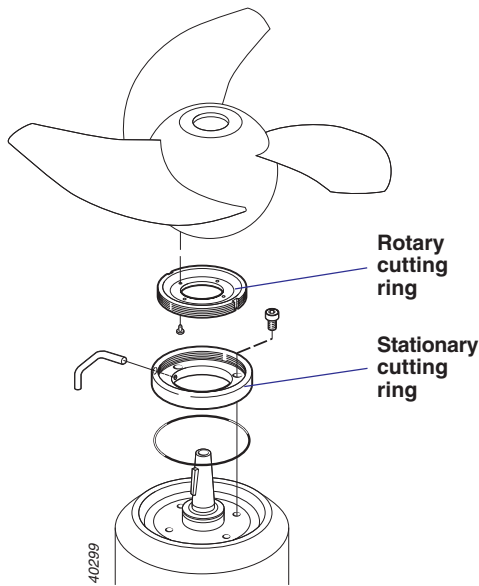

## Cooling jacket

The machine can be equipped with cooling jacket.

Pipes and couplings are connected between the cooling jacket and the fixing plate. Cooling water is accessible at the fixing plate.

The fixing plate is provided with five threaded holes ISO G-3/8 for inspection and change of oil, cooling water and seal flushing.

For easy handling, the cooling water holes can be equipped with hydraulic couplings or couplings with hose clips.

After propeller and jet ring removal, the cooling jacket is assembled by pushing it from the mixers' propeller side on the stator housing. To make it easy, soap water can be used.

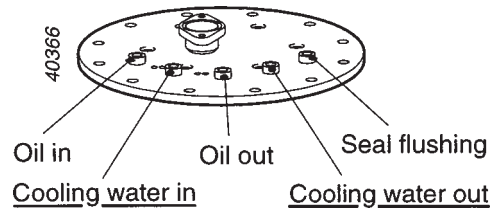

Recommended flow for the cooling water is shown in the table below. Cooling water temperature 20°C (68°F).

Mixer size	Flow l/min
4630, 4640	2
4650, 4660	6
4670, 4680	10

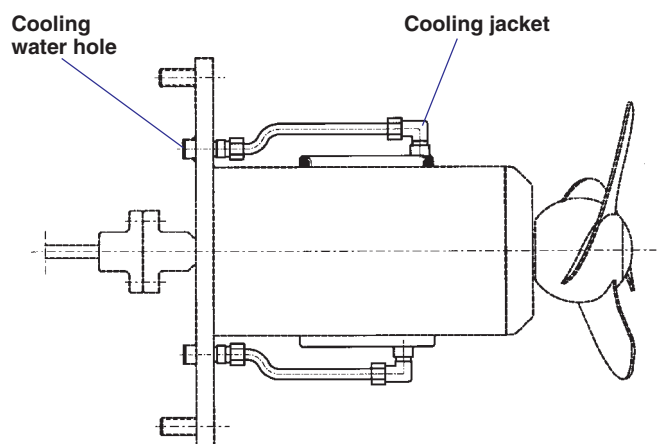

# Fault Tracing (Troubleshooting)



**Ex-approved machine!**

**All work on the explosion-proof motor section must be performed by personnel authorized by Flygt.**

A universal instrument (VOM), a test lamp (continuity tester) and a wiring diagram are required in order to carry out fault tracing on the electrical equipment.

Fault tracing should be done with the power supply disconnected and locked off, except for those checks which cannot be performed without voltage.

Always make sure that there is no one near the machine when the power supply is turned on.

Use the following checklist as an aid to fault tracing. It is assumed that the mixer and installation have formerly functioned satisfactorily.

Electrical work must be performed by an authorized electrician.

Follow local safety regulations and observe recommended safety precautions.

## 1. The machine fails to start

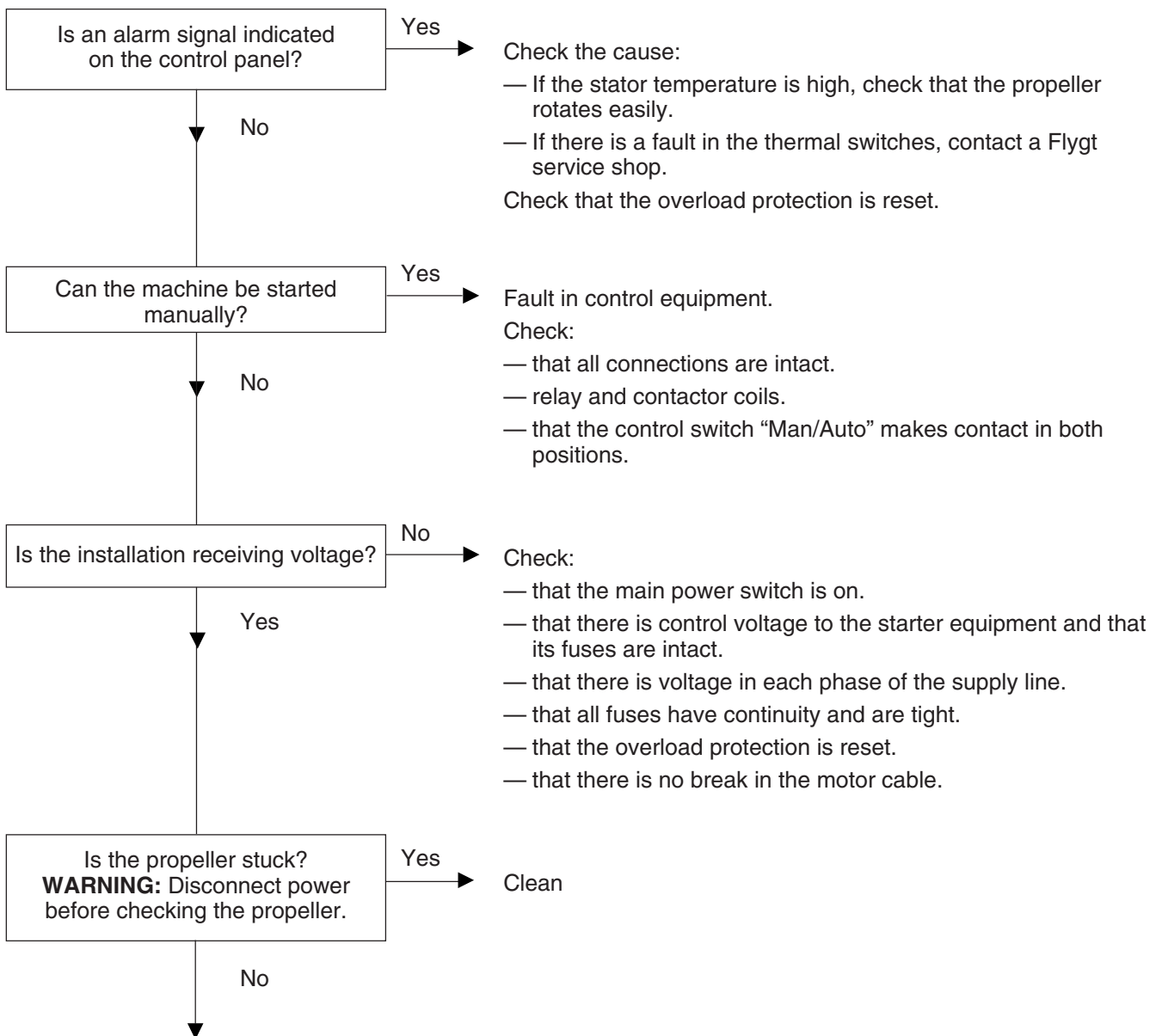

Contact Flygt service shop.

## 2. The machine starts but motor protection trips

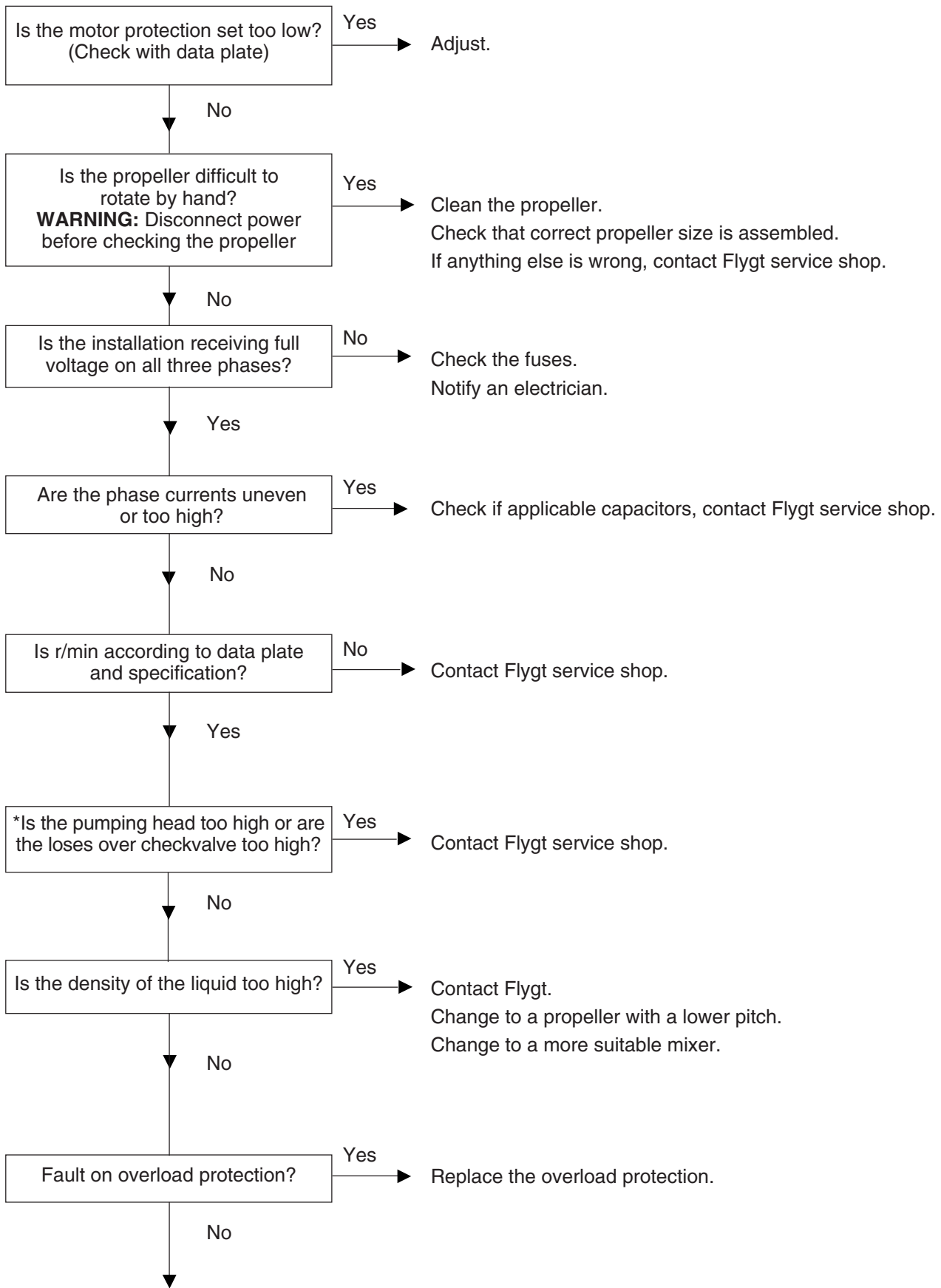

Contact Flygt service shop.

\* only for PP-pump

### 3. The machine starts-stops-starts in rapid sequence

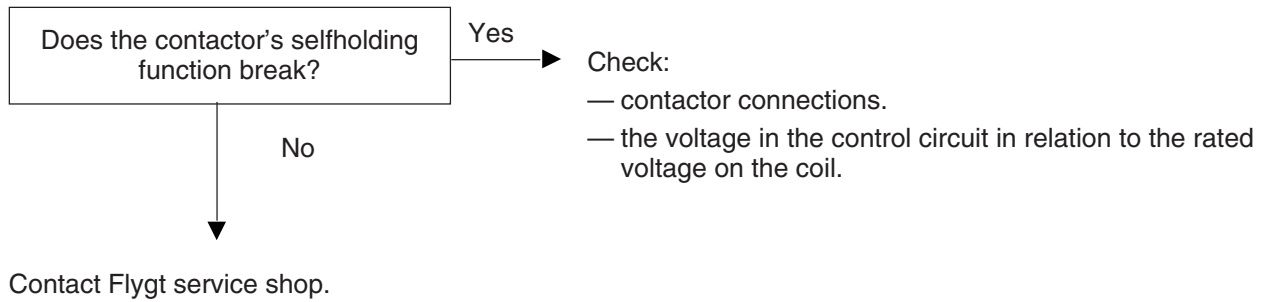

**Do not override the motor protection repeatedly if it has tripped.**

# SERVICE LOG

Most recent service date	Mixer or Pump No.	Hours of operation	Remarks	Sign.





[www.flygt.com](http://www.flygt.com)