

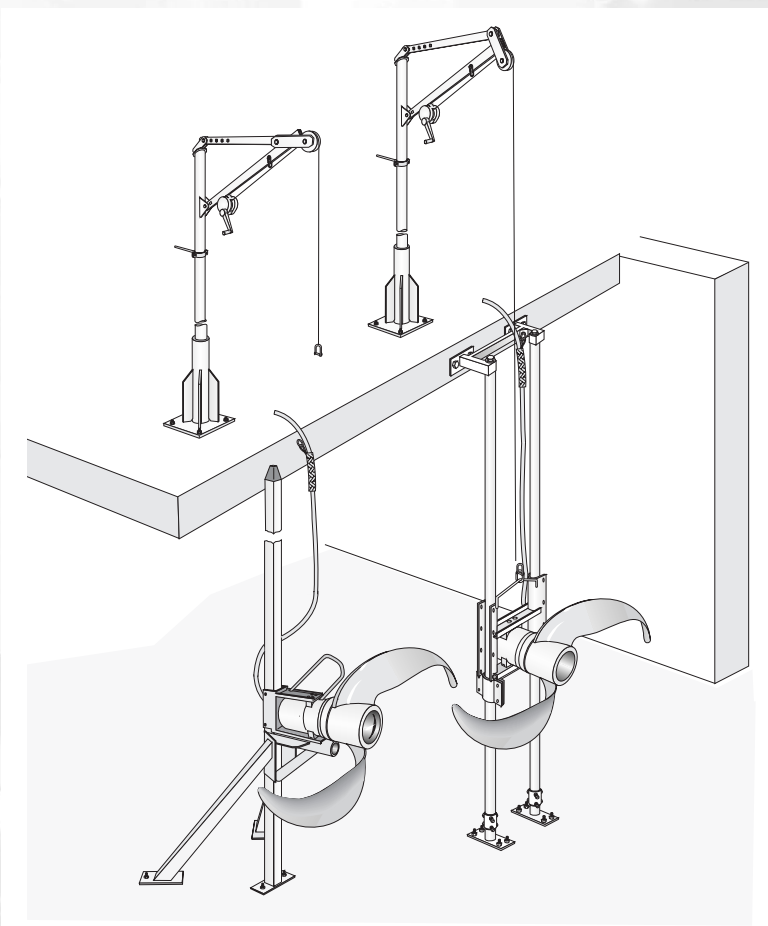

# Installation, care and maintenance

Double guide and tripod guide bar system





**FLYGT**An **ITT Industries** company**EU declaration of conformity**

**Manufacturer:** Company name: **ITT Flygt AB**  
 Address: **S-361 80 EMMABODA** Telephone: **+ 46 471 170 00**  
**SWEDEN**

**Hereby certify that:**

<b>Davit:</b>	Type:	150 kg	Part number:	623 11 00/01, 622 98 00/01, 623 04 00/01
		300 kg		624 27 00/01, 623 55 00/01, 623 59 00/01
		320 kg		624 26 00/01, 623 55 00/01, 623 59 00/01
		600 kg		624 28 00/01, 623 55 00/01, 623 59 00/01

\* has been manufactured in accordance with the COUNCIL'S DIRECTIVE concerning convergence of the legislation of Member States with regard to Machinery (90/27/EC (89/392/EEC) + 91/368/EEC + 93/44/EEC + 93/68/EEC), EMC (89/336/EEC),  
 \* has been manufactured in accordance with the following harmonized standards and technical spec: EN 292/1, EN 292/2,  
 \* National standard DIN 15016 Teil 1, DIN 15020 Blatt 1+2, DIN 15021, VBG 8, VBG 9, VBG 9a (Davit 300, 320, 600 kg),  
 \* National standard NF E 52110 (Davit 150 kg).

Title: **Product Line Manager** Name: **Lars Frisk**  
 Company name: **ITT Flygt AB** Signature: *Lars Frisk* Date: **2000-06-08**

# CONTENTS

**This "Installation, Care and Maintenance" applies to double guide bar system and tripod guide bar system for 4410 and 4430.**

	Page		Page
<b>Introduction</b>		<b>Guide bar system</b>	
<b>Guarantee</b> _____	4	<b>1. Double guide bar system</b> _____	9
<b>Transportation and storage</b> _____	4	General description	
<b>Safety precautions</b> _____	4	Erection procedure	
<b>Handling equipment</b> _____	4	<b>2. Tripod guide bar system</b> _____	11
<b>Lifting system</b>		General description	
<b>1. Environment of lifting system</b> _____	5	Erection procedure	
<b>2. Lifting system</b> _____	6	<b>Dimensions</b> _____	13
- Lifting davit _____	6	<b>Installing the mixer</b> _____	14
General description			
Erection procedure			
<b>3. Lifting equipment</b> _____	8		
- Winch _____	8		
Erection procedure			
- Chain, block and tackle _____	8		

# INTRODUCTION

## GUARANTEE

ITT Flygt undertakes to remedy faults in products sold by ITT Flygt provided:

- That the fault is due to defects in design, materials or workmanship;
- That the fault is reported to ITT Flygt or ITT Flygt's representative during the guarantee period;
- That the product is used only under conditions described in the care and maintenance instructions and in applications for which it is intended;
- That the monitoring equipment incorporated in the product is correctly connected;
- That all service and repair work is done by a workshop authorized by ITT Flygt;
- That genuine ITT Flygt parts are used.

Hence, the guarantee does not cover faults caused by deficient maintenance, improper installation, incorrectly executed repair work or normal wear and tear.

ITT Flygt assumes no liability for either bodily injuries, material damages or economic losses beyond what is stated above.

ITT Flygt guarantees that a spare parts stock will be kept for 15 years after the manufacture of this product has been discontinued.

The manufacturer reserves the right to alter performance, specification or design without notice.

## TRANSPORTATION AND STORAGE

If the lifting and handling accessories are not installed at the time when they are received, they should be stored in a room free from moisture.

During transportation and handling it is important to avoid impacts that might deform accessories or damage their anticorrosive coating.

## SAFETY PRECAUTIONS

In order to minimize the risk of accidents in connection with the service and installation work, the following rules should be followed:

1. Never work alone. Use a lifting harness (part No. 84 33 02), a safety line (part No. 84 33 03) and a respirator (part No. 84 33 01), as required. Do not ignore the risk of drawing!
2. Make sure that there is sufficient oxygen and that there are no poisonous gases present.
3. Check the explosion risk before welding or using electric hand tools.

4. Do not ignore health hazards. Observe strict cleanliness.
5. Bear in mind the risk of electrical accidents.
6. Make sure that the lifting equipment is in good condition.
7. Provide a suitable barrier around the work area, for example a guard rail.
8. Make sure that you have a clear path of retreat!
9. Use a safety helmet, safety goggles and protective shoes.
10. All personnel who work with sewage systems should be vaccinated against diseases that can occur.
11. A first-aid kit must be handy.
12. The weight of certain accessories requires the use of suitable handling equipment.

Follow all other health and safety rules and local codes and practices.

### ATTENTION!

In order to avoid accidents, warning signs for rotating propellers and machines that start automatically must be positioned visibly.

The area in the proximity of the machines should be fenced off.

## HANDLING EQUIPMENT

Lifting equipment is required for handling the mixer.

The lifting device should not have a lifting capacity which is greater than twice the weight of the mixer.

Oversized lifting equipment could cause damage if the mixer gets stuck when being lifted.

Make sure that the lifting equipment is securely anchored.

**WARNING!** Keep out from suspended load.

Comply with the instructions for using chemical dowels of the Spit Maxi EA or similar type.

Observe in particular:

- do not drill the holes too close to the concrete edge.
- the proximity of the clear edge of the concrete (see layout and civil engineering recess drawings).
- the drying time of the chemical capsules, ranging from 20 minutes to 5 hours in dry concrete depending on ambient temperature.

For more information, see manufacturer's instructions entitled "Chemical dowel, rules for definition and identification of use and placing".

# LIFTING SYSTEM

## Materials

**Stainless steel**

EN1.4432  
ASTM 316L

**Galvanized steel, hot dip**

EN1.0038  
ASTM-A 36

## 1. ENVIRONMENT OF LIFTING SYSTEM

To be able to use the lifting accessories properly for handling the mixer, it is important to arrange sufficient space around the davit:

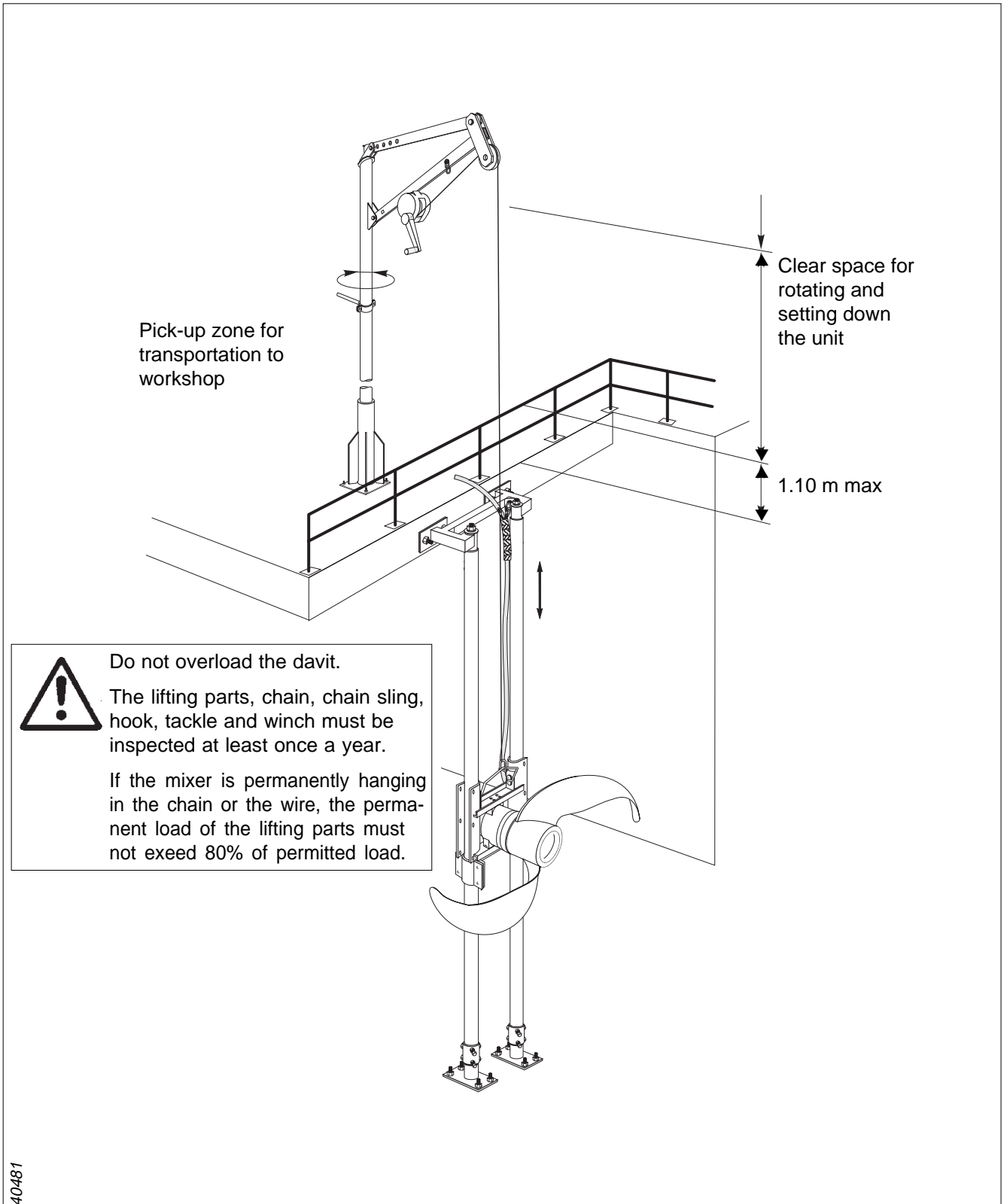

40481

# LIFTING SYSTEM

## General description

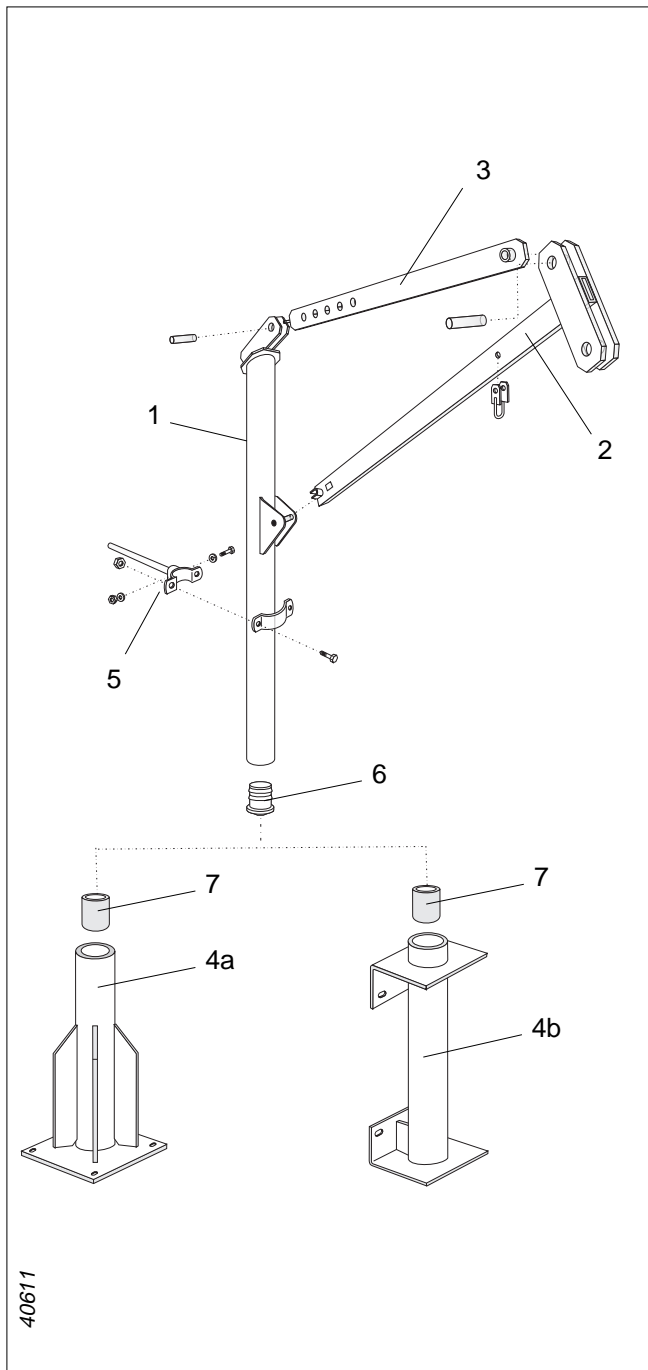

### Nomenclature

- 1 Lifting davit pipe
- 2 Lifting davit unit
- 3 Lock plate unit
- 4a Davit holder, floor mounted
- 4b Davit holder, wall mounted
- 5 Operating bar
- 6 Sleeve
- 7 Sleeve

### Davit 300

dimension, mm

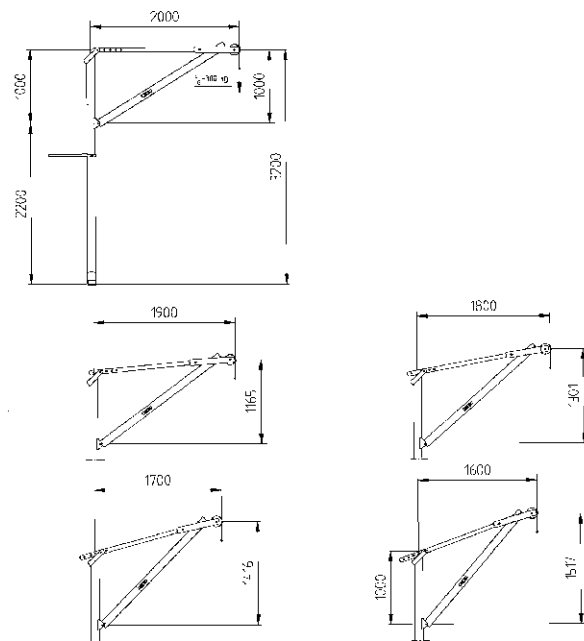

### Davit 320

dimension, mm

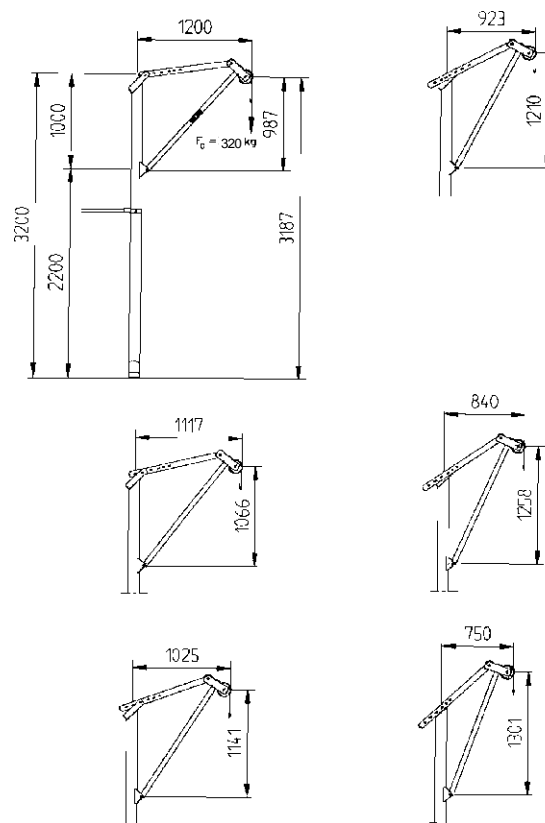

## Erection procedure, davit 300 and 320

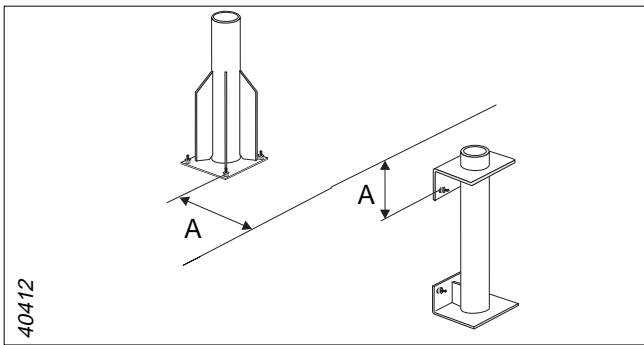

1) Position the holder (4) according to the layout and civil engineering recess drawings.

$A = \text{min } 65 \text{ mm}$ , recommended  $125 \text{ mm}$ .

Fix the davit holder (4) with chemical dowels, max torque  $60 \text{ Nm}$ .

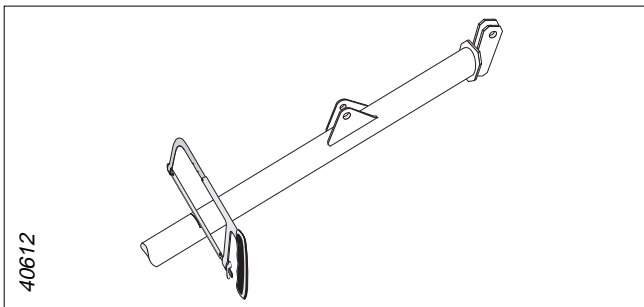

2) If required adjust the pipe to proper length. Remove the sleeve and cut the pipe. Reassemble the sleeve.

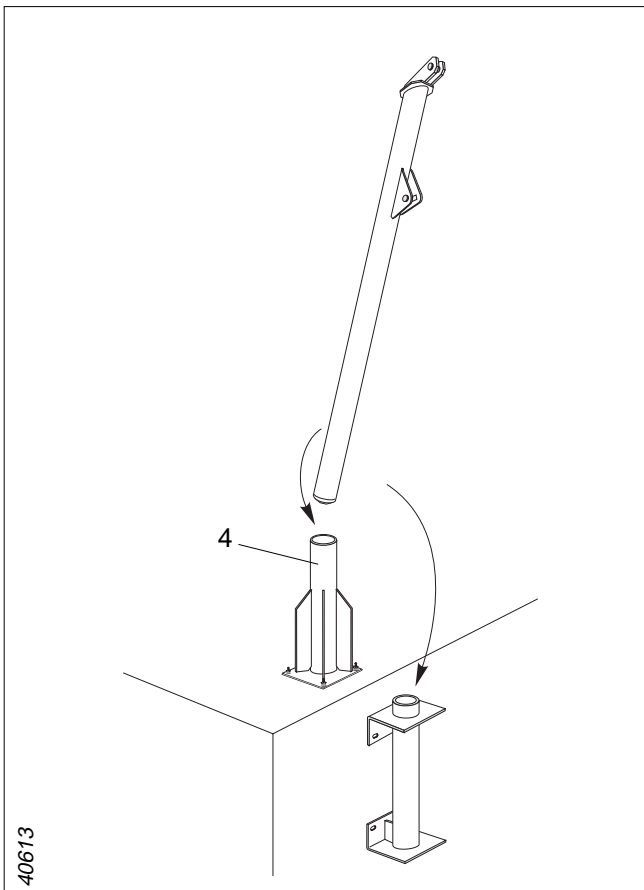

3) Install the lifting davit pipe unit in the davit holder (4).

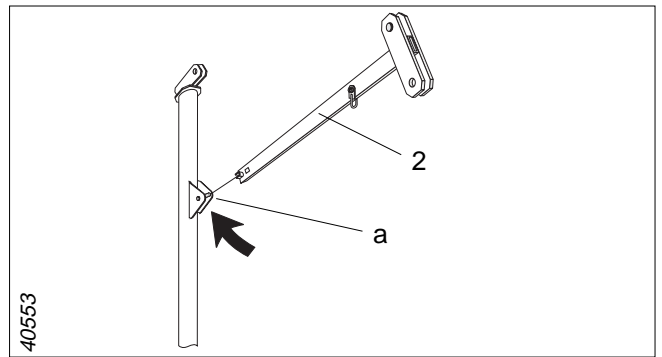

4) Lift up the lifting davit unit (2) and put it in the bracket a.

Secure the lifting davit unit (2) with the pin.

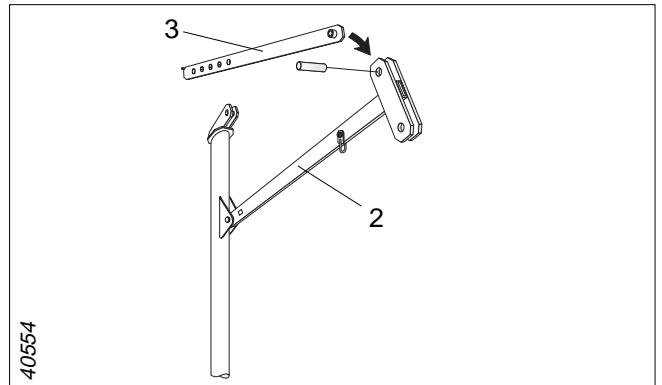

5) Fix the lifting davit unit (2) and lock plate unit (3) together with the pin and secure it.

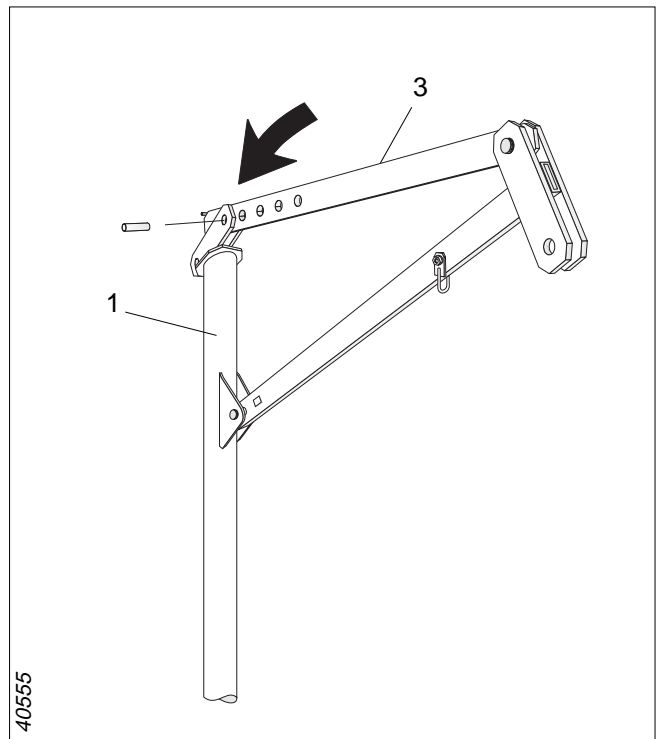

6) Choose hole in the lock plate unit (3) and fit it together with davit pipe (1). Use the pin and secure it.

### 3. LIFTING EQUIPMENT

**IMPORTANT:** the lifting accessories should never be used for suspending persons or equipment that is operating.

#### Winch

**The various types of winches used:**

Winch for 4410 - 4430 maximum load 300 or 350 kg.  
For each of these winches there is a purpose-made winch bracket.

The winches are CE-marked and approved.

#### Erection procedure, winch to the davit pipe

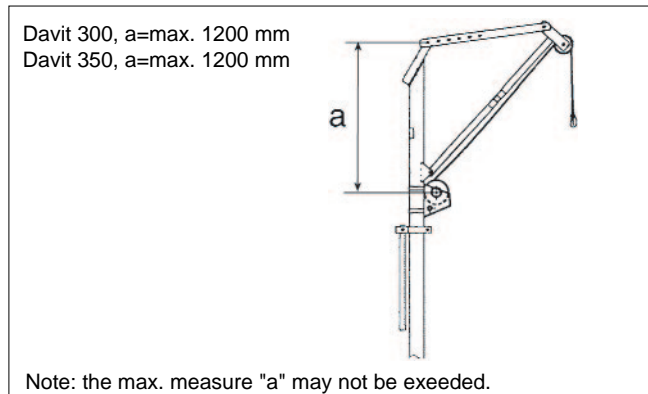

1) Use the bolts provided to fix the winch to the bracket.

Check that the “top” and “bottom” marks on the winch bracket are correctly oriented.

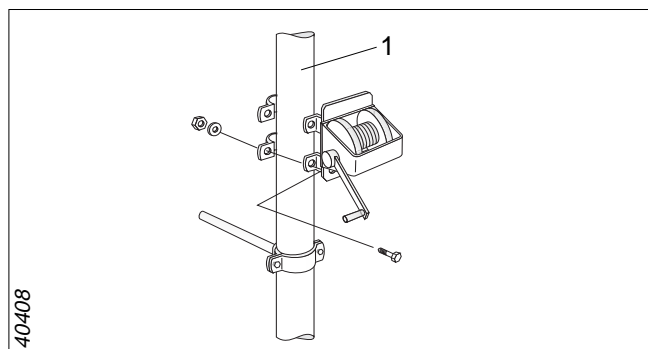
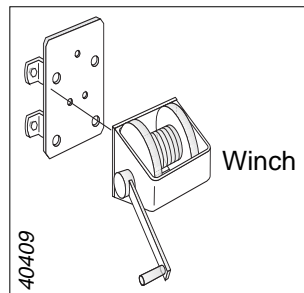

2) Fix the winch to the davit pipe so that:

- it is easy for the operator to adjust (height setting)
- the center of the drum is on the centerline of the davit arm

Use the clamping nuts to lock it in position on the davit pipe (1).

#### Erection procedure, winch to the davit unit

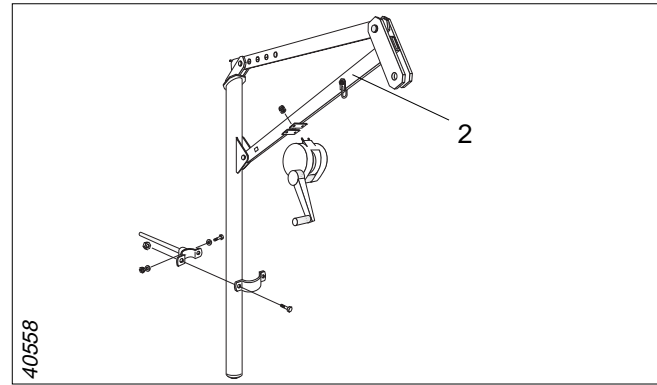

1) Fix the winch to the lifting davit unit (2) so that:

- it is easy for the operator to adjust (height setting)
- the center of the drum is on the centerline of the davit arm

Use the brackets and fit the winch to the lifting davit unit (2). Winch winding handle on the right.

#### Chain, block and tackle

Calibrated lifting chain max. load 500 kg in 5, 9 or 20 m length.

Chain links with abbreviature hook and shackle max. load 500 kg, length 0,75 m. Corner block max. load 400 kg. Block and tackle max. load 500 kg.

Chain, block and tackle are CE-marked and approved.

#### Erection procedure

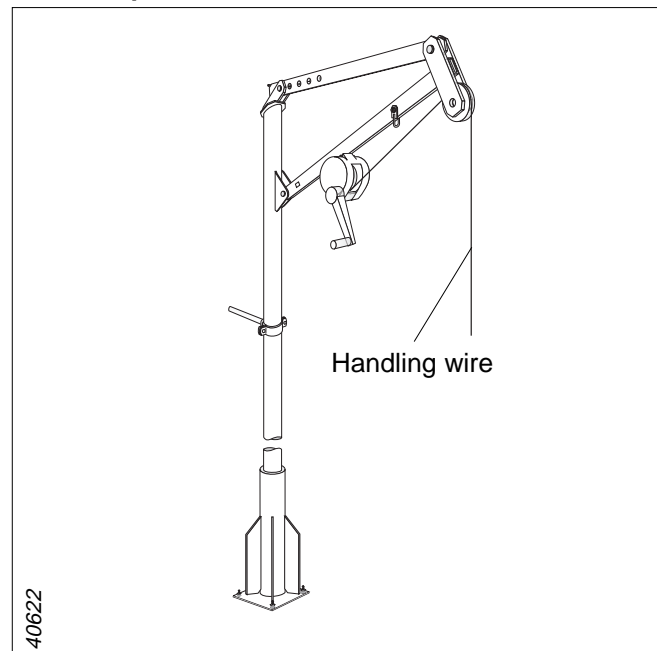

1) Place the cord pulley or block and tackle so that the handling chain or wire is vertical.

**Note:** the lifting accessories may be used for installing the guide accessories.



# GUIDE SYSTEM

## Materials

### Stainless steel

EN1.4432  
ASTM 316L

### Galvanized steel, hot dip

EN1.0038  
ASTM-A 36

## 1. DOUBLE GUIDE BAR SYSTEM

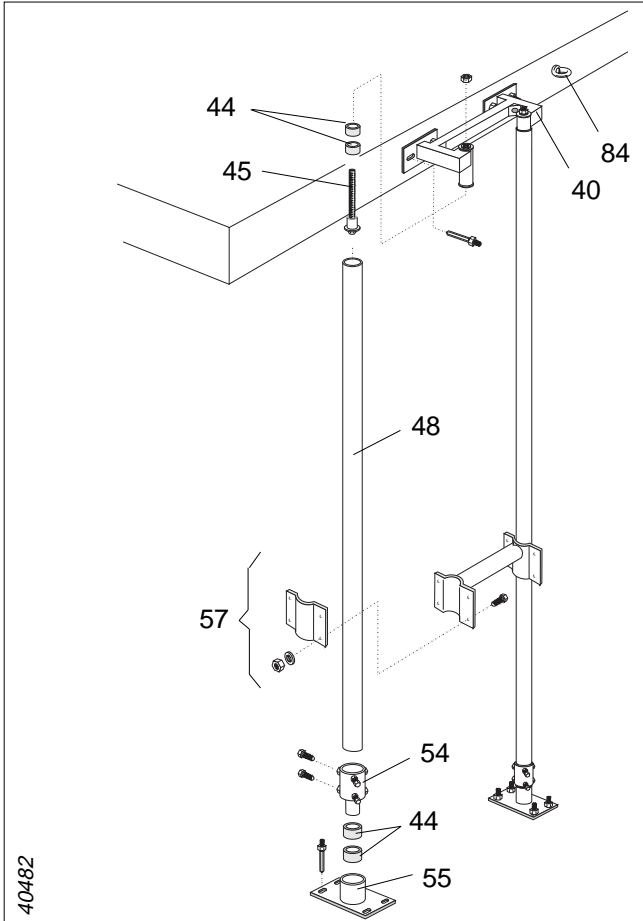

### Nomenclature

44	Rubber sleeve
45	Compression rod
40	Upper guide bracket
48	Guide bar
54	Lower bar guide
57	Support unit
55	Lower guide bracket
84	Eye bolt

## Guide bars

Mixers 4410/4430; guide bar diameter 114,3 mm, thickness 4,5 mm for L = 6 m.

The standard bar length is 3 or 6 m, longer bars on request.

## Erection procedure

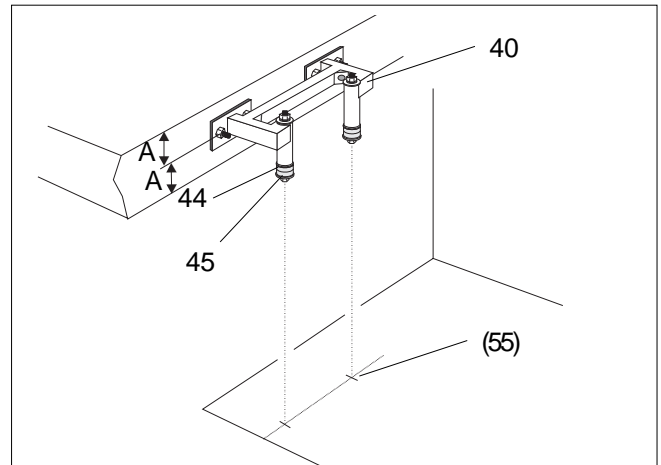

- 1) Mark out the position for the guide brackets (40) and (55) by means of the layout and civil engineering recess drawings.

A=min 65 mm, recommended 125 mm.

Place the upper guide bracket (40) in position but leave it untightened.

**Note:** in the majority of cases, the guide bars are aligned with the centerline of the davit.

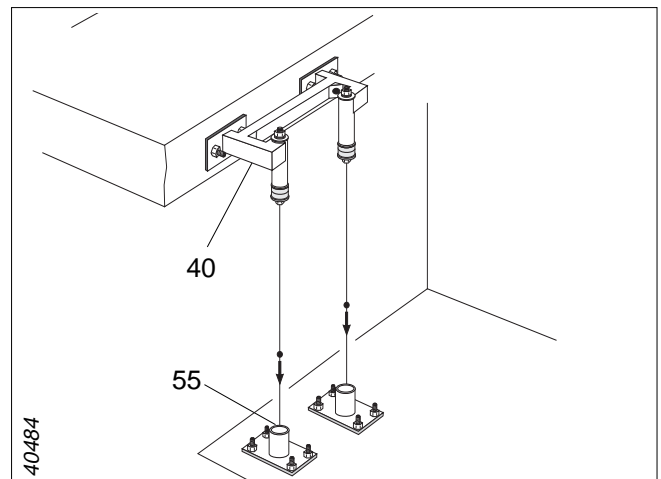

- 2) Check the positioning of the lower guide brackets (55). Use a plumb line to check that each of the lower brackets (55) is properly aligned vertically with the centerlines of the upper brackets (40).

Fix the lower guide brackets (55).

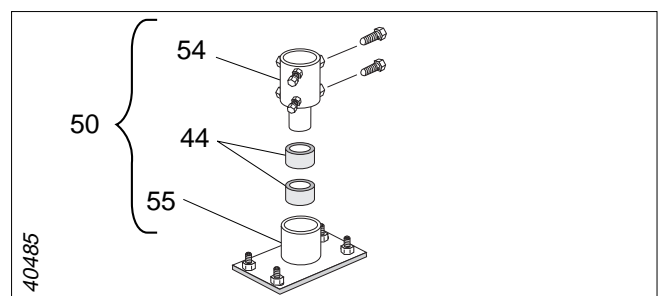

- 3) Place the two rubber bushes (44) around the lower bar guide (54) and insert the assembly in the lower guide bracket (55).

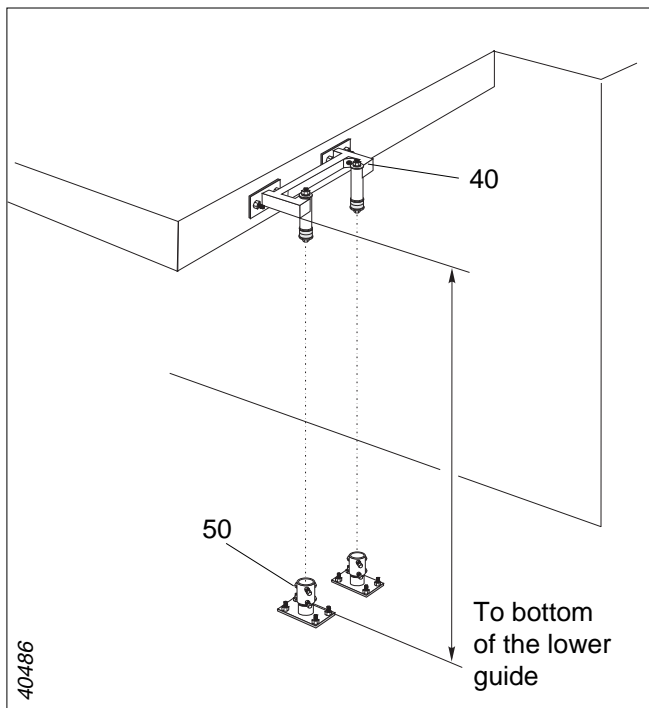

- 4) Measure the distance between the bottom of the lower guide (50) and the underside of the upper guide bracket (40). Subtract 2 cm from the measurement to arrive at the dimension at which the guide bar (48) should be cut.

**Note:** The cut end of the guide bar should point downwards.

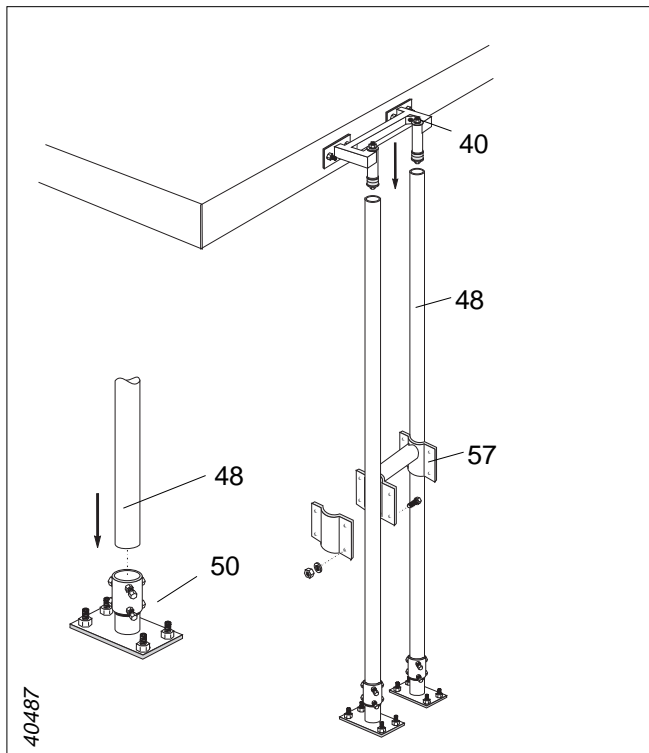

- 5) Remove the complete upper guide bracket (40). Insert the guide bars (48) into the lower guides (50), present the support (57) between the two bars and fix it untightened at a height close to the recommended height, then engage the upper guide and fix the upper bracket (40) and lock it in position.

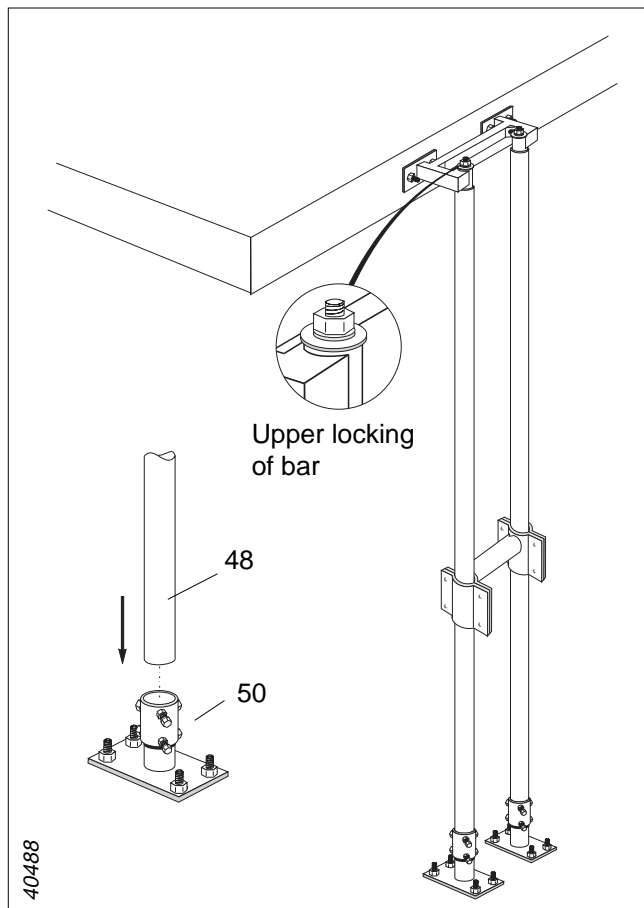

- 6) Tighten the clamping screws of the lower bar guides (50) and lock the guide bars by tightening the compression rods (45).

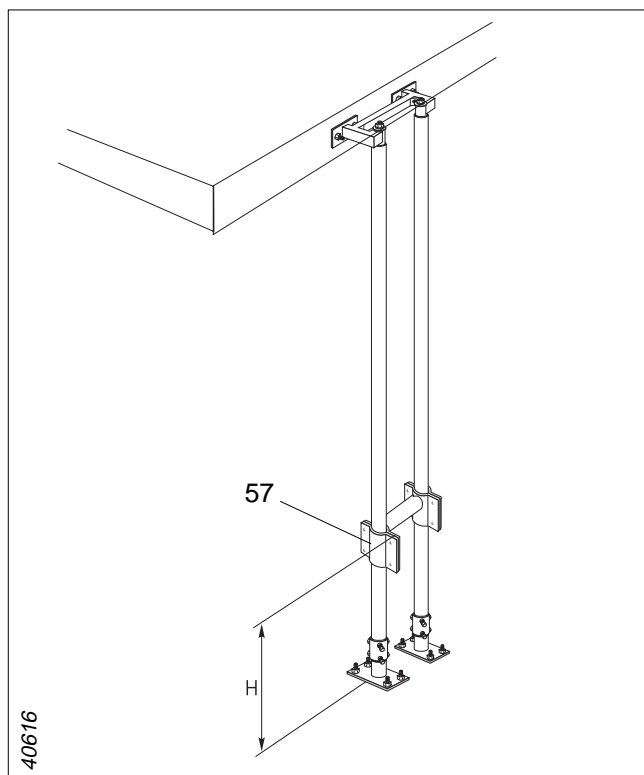

- 7) Adjust the support (57) to the proper height from the tank bottom, following the recommendations (height H).

The guide system is ready to receive the mixer.

## 2. TRIPOD GUIDE BAR SYSTEM

### Materials

Stainless steel  
EN1.4432  
ASTM 316L

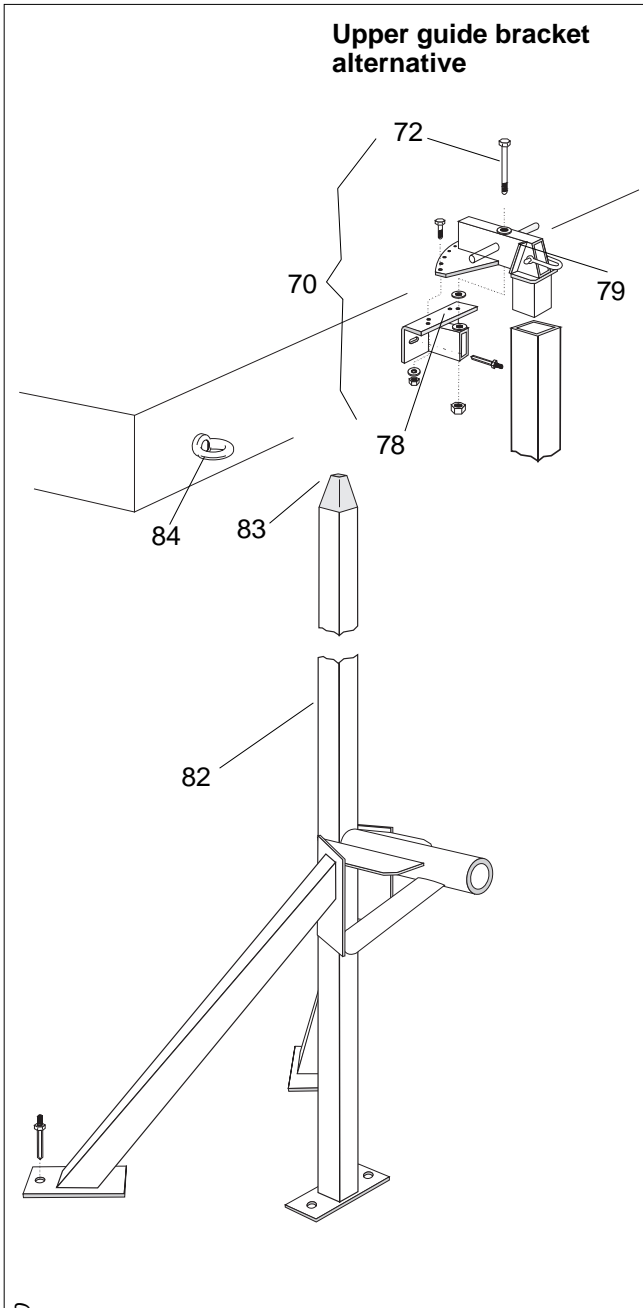

40540

#### Nomenclature

70	Guide bar bracket
72	Screw
78	Bracket
79	Bracket
82	Guide bar with fixed support
83	Tap
84	Eye bolt

### Erection procedure

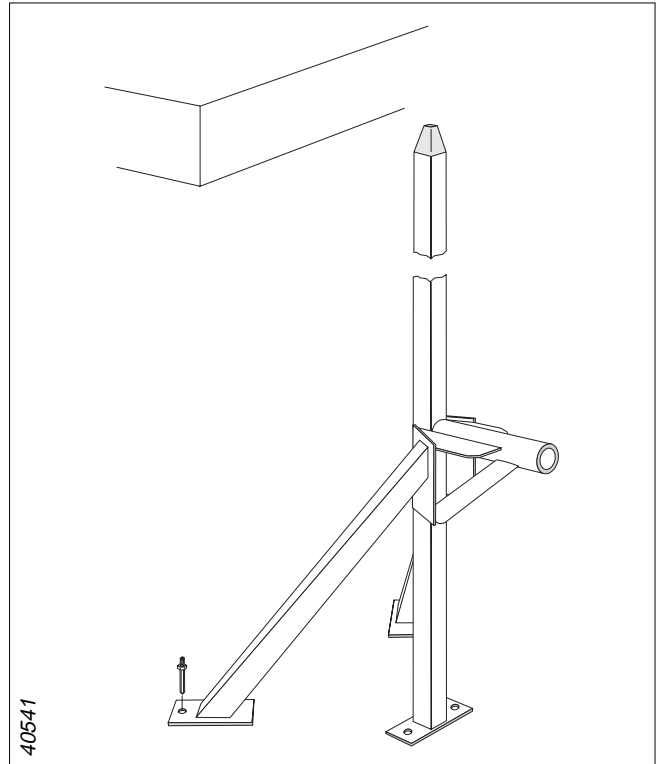

40541

1) Fit the lower brackets.

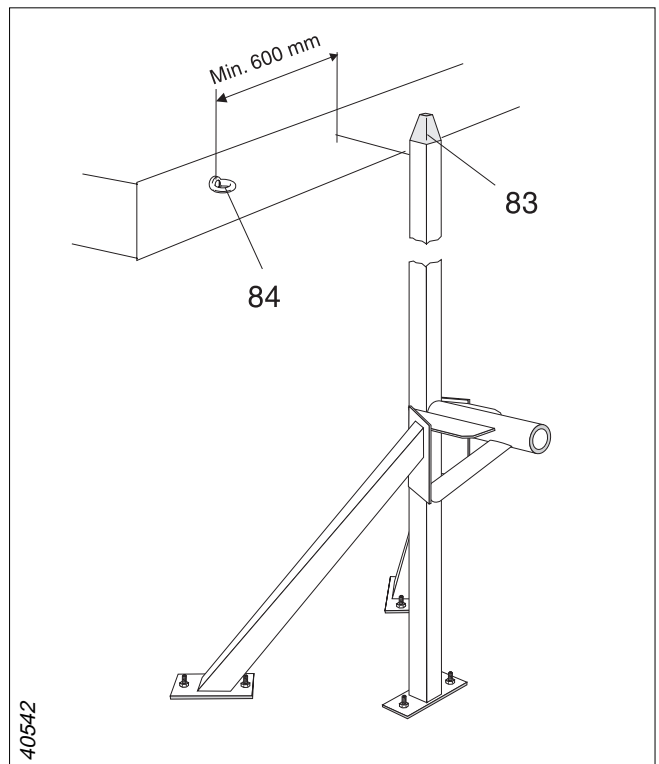

40542

2) Fit the tap (83) in the top of the guide bar. Fit the eye bolt (84) in the wall.

The guide system is ready to receive the mixer.

## Erection procedure

### Upper guide bracket alternative

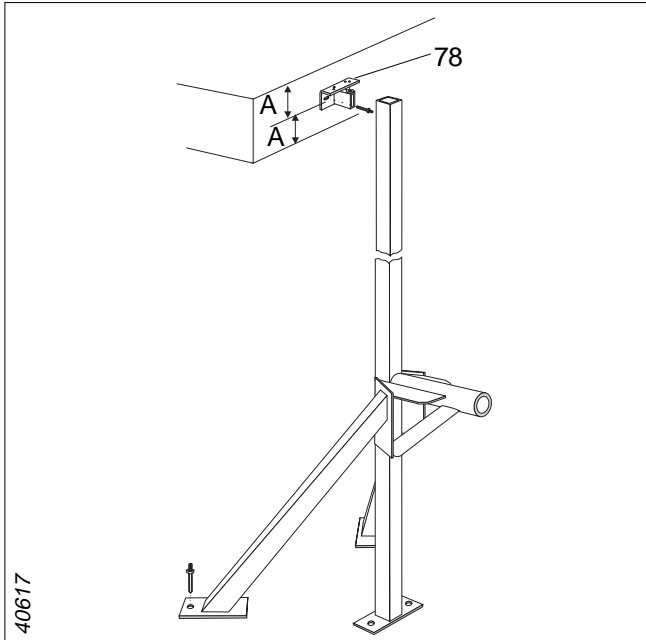

1) Position the bracket (78) according to the layout and engineering recess drawings.

A= min 65 mm, recommended 125 mm.

**Note:** in the majority of cases, the guide bars are aligned with the centreline of the davit.

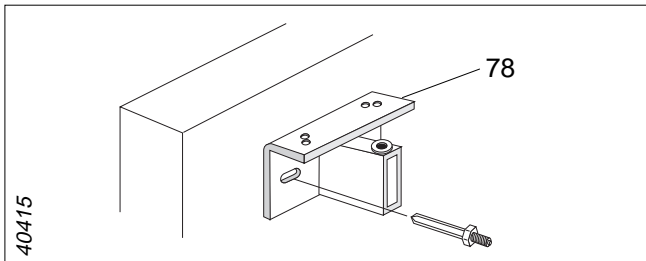

2) Fit the upper bracket (78).

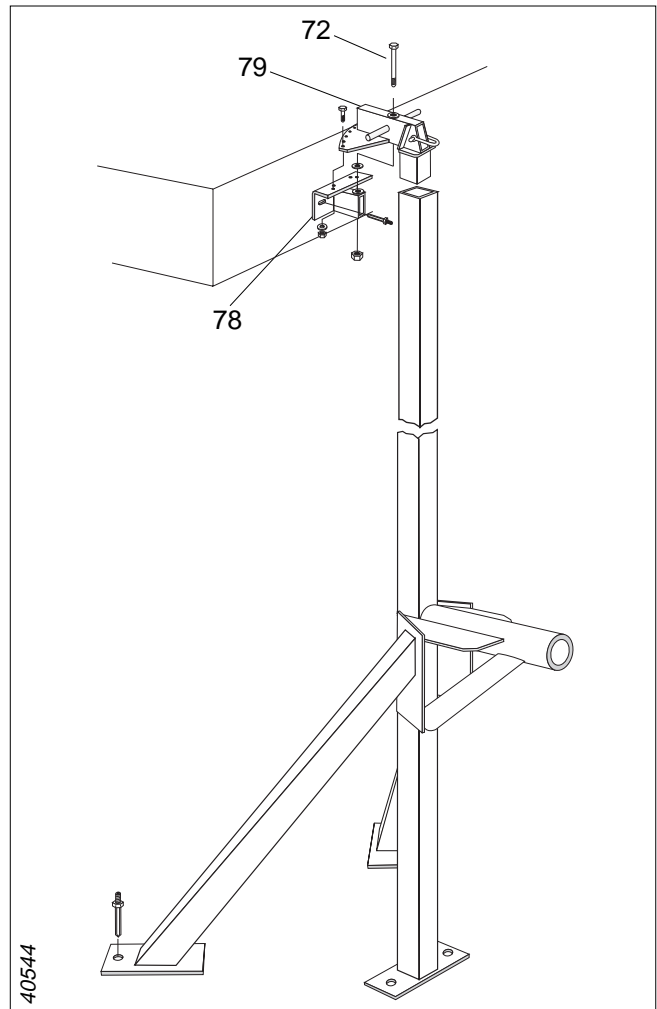

3) Fit the upper bracket (79) onto the guide bar.

Fix upper guide bar brackets (78 and 79) together with the bolt (72) and tighten.

Fit the lower brackets.

The guide system is ready to receive the mixer.

# DIMENSIONS

Measurement for mounting of bracket.

Dimensions

in mm

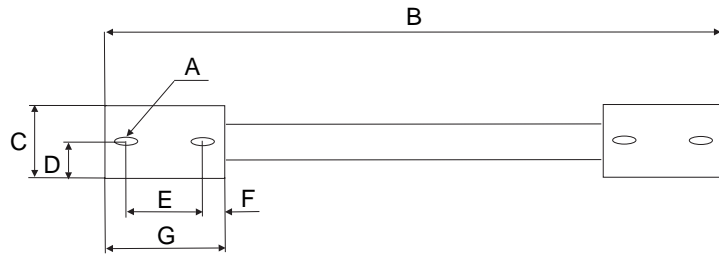
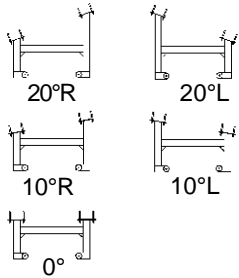
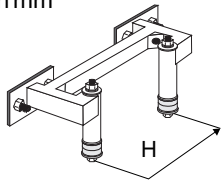

	A	B	C	D	E	F	G	H
0°	Ø18	1294	150	75	180	35	250	c:c 800
10°	Ø18	1308	150	75	180	35	250	c:c 800
20°	Ø18	1363	150	75	180	35	250	c:c 800

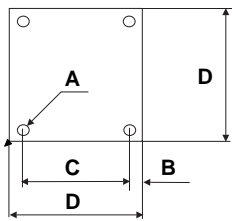
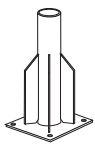

A	B	C	D
Ø18	20	300	340

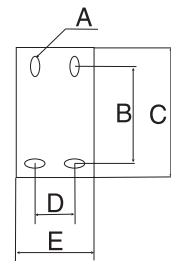
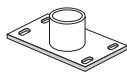

A	B	C	D	E
Ø18	185	250	100	170

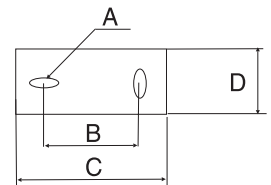

A	B	C	D
Ø18	190	260	100

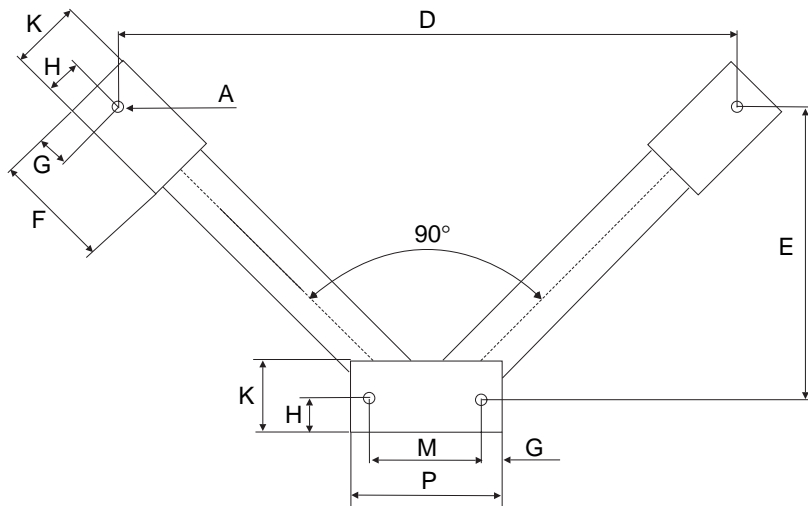
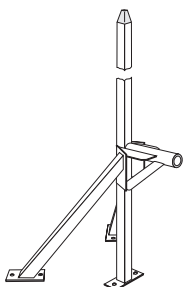
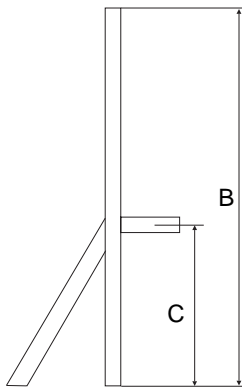

A	B	C	D	E	F	G	H	K	M	P
Ø18	3015	800	920	350	200	25	60	120	310	360
Ø18	6015	1100	1160	470	200	25	60	120	310	360
Ø18	3015	1350	1370	575	200	25	60	120	310	360
Ø18	6015	800	920	350	200	25	60	120	310	360
Ø18	3015	1100	1160	470	200	25	60	120	310	360
Ø18	6015	1350	1370	575	200	25	60	120	310	360

# INSTALLING THE MIXER

Before installing the mixer, carry out the checks stated in the installation and maintenance instructions.

## PROCEDURE FOR INSTALLING THE MIXER

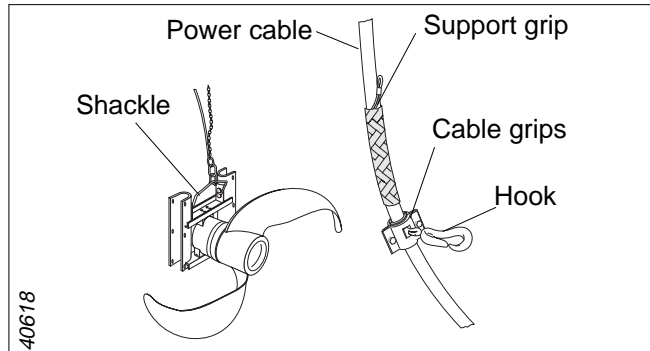

- 1). Attach the retaining chain or wire to the mixer by means of the shackle recommended by Flygt. Attach the handling cable or chain to the unit. Place cable grips on the power cable at intervals of about 1,5 m.

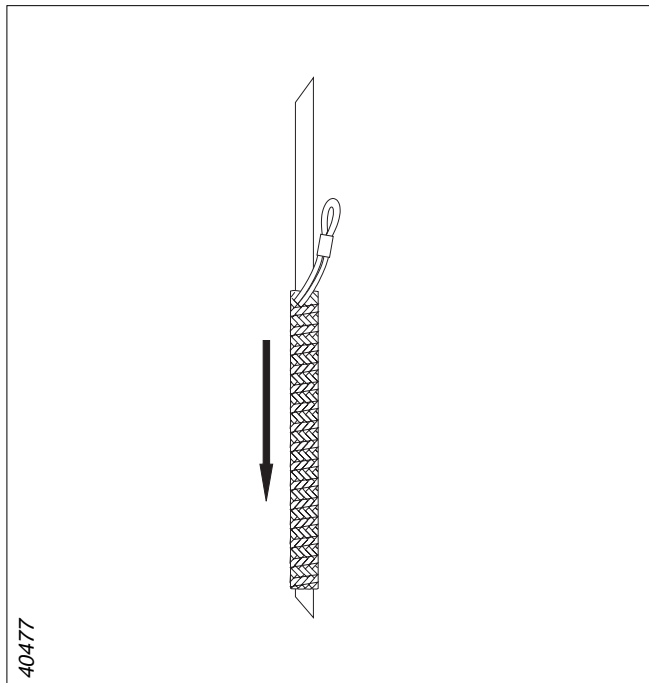

- 2). Place the support grip in position on the power cable and attach it with a shackle.

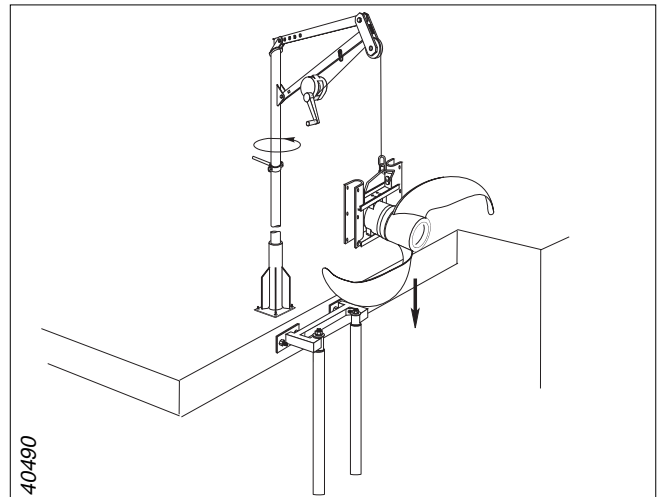

- 3). Raise the mixer and pivot it by operating the handle on the davit.

**Note:** The handling chain or wire must be vertical to the bars.

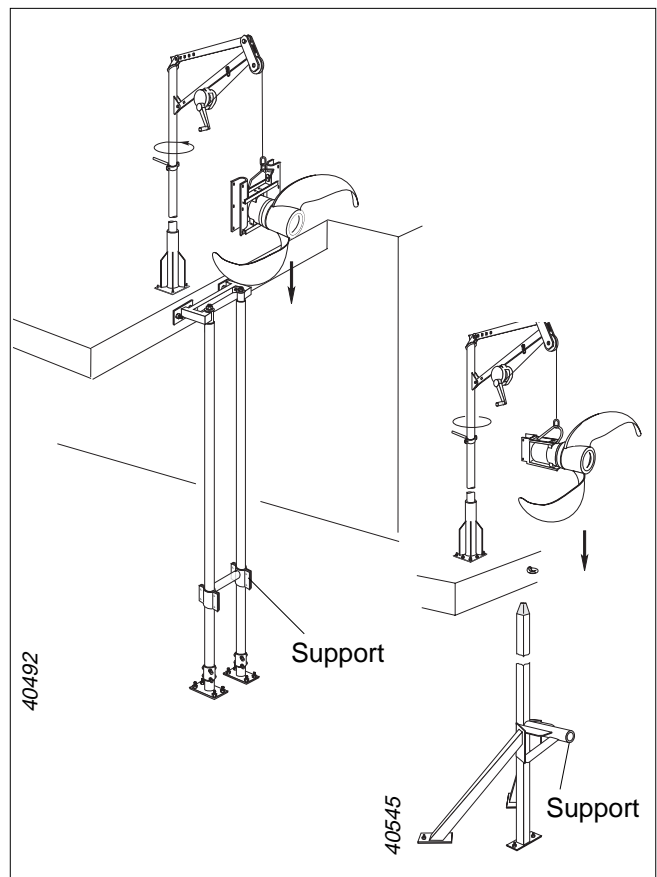

- 4). Lower the mixer, positioning it on the guide bars to the support.

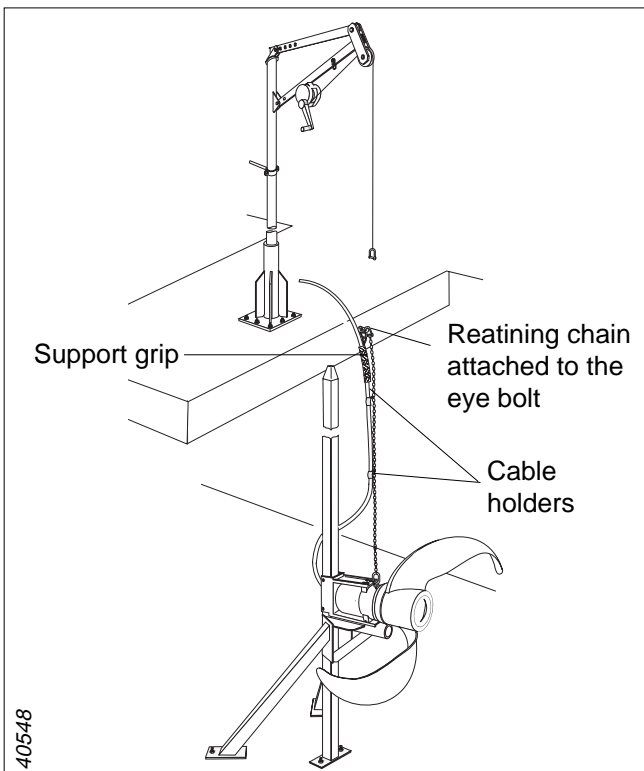
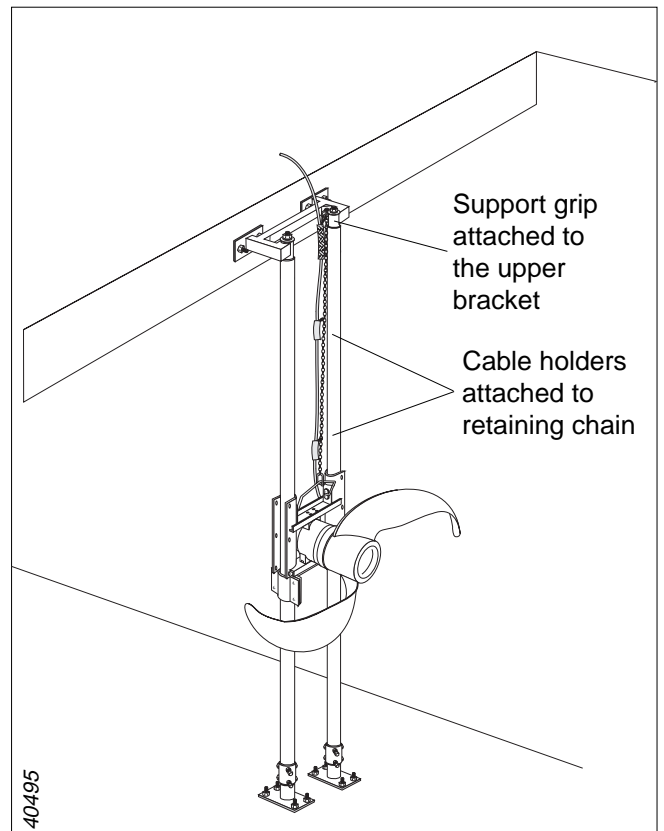
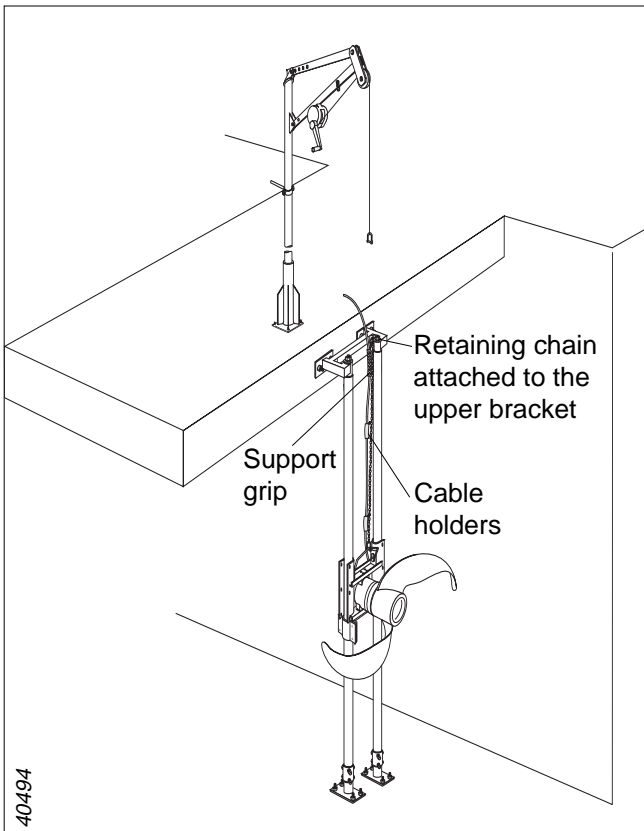

6) Place power cable holders on the retaining wire or chain at intervals of 1,5 m while keeping the power cable slightly taut (mark the links to be attached to). Attach the support grip to the upper bracket/eye bolt by means of the shackle supplied.

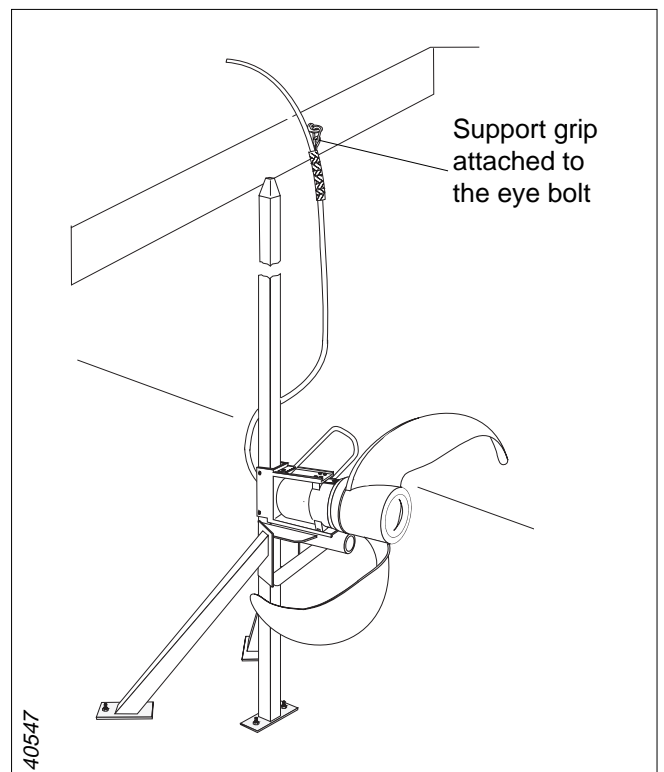

5) Fix the wire or chain to the davit or to the upper guide bracket/eye bolt by means of a shackle.

**Note:** It is important to make sure that the retaining chain or wire is taut enough not to be sucked into the propeller of the mixer.

In addition, in the case of a chain, movement of one link on another has to be prevented in order to avoid premature wear. It is recommended that the wire or chain should be fixed at the upper bracket /eye bolt with a shackle.

The mixer is ready to be connected to the power supply (see manual entitled "Installation, care and maintenance for the mixer").

