



# Installation, Care and Maintenance

4410, 4430



# CONTENTS

This “Installation, Care and Maintenance” applies to the following versions of the mixer:

<b>4410</b>	<b>4430</b>
4410.011, 4410.090,	4430.010, 4430.090,

## Identification of safety and warning symbols



### General Danger:

Non-observance given to safety instructions in this manual, which could cause danger to life have been specifically highlighted with this general danger symbol.



### High Voltage:

The presence of a dangerous voltage is identified with this safety symbol.

## WARNING!

Non-observance to this warning could damage the unit or affect its function

	Page
<b>Guarantee</b> _____	3
<b>Data plate</b> _____	4
<b>Product description</b> _____	5
Applications _____	5
Materials _____	5
Weights _____	5
Motor data _____	6
Design _____	7
Possible combinations and performance data _____	8
<b>Transportation and storage</b> _____	10
<b>Installation</b> _____	10
Safety precautions _____	10
Handling equipment _____	11
Installation alternatives _____	11
<b>Electrical connections</b> _____	12
Capacitive leakage sensor CLS-10 _____	16

	Page
<b>Operation</b> _____	17
Before starting _____	17
During operation _____	17
<b>Care and maintenance</b> _____	17
Safety precautions _____	17
Service _____	18
Recommended inspections _____	19
Changing the oil _____	21
Propeller unit _____	22
Removing the propeller blades _____	22
Removing the hub _____	22
Fitting the hub _____	23
Fitting the propeller blades _____	24
<b>Fault tracing (Troubleshooting)</b> _____	25
<b>Accessories and tools</b> _____	27
Zinc anode set _____	27
Start and control equipment _____	27
Tools _____	27

# NOTES FOR EXPLOSION APPROVED MACHINES

The explosion proof version (Ex-approved) is designed for use in explosive environments in accordance with approval stated on page 4.



**According to rules the Ex-approved mixer must always work completely submerged in the liquid.**



**Thermal contacts must be used on Ex-approved machine due to approval conditions.**

**All work on the explosion-proof motor section must be performed by personnel authorized by Flygt.**

**Flygt disclaims all responsibility for work done by untrained, unauthorized personnel.**

## GUARANTEE

Flygt undertakes to remedy faults in products sold by Flygt provided:

- that the fault is due to defects in design, materials or workmanship;
- that the fault is reported to Flygt or Flygt's representative during the guarantee period;
- that the product is used only under conditions described in the care and maintenance instructions and in applications for which it is intended;
- that the monitoring equipment incorporated in the product is correctly connected;
- that all service and repair work is done by a workshop authorized by Flygt;
- that genuine Flygt parts are used.

Hence, the guarantee does not cover faults caused by deficient maintenance, improper installation, incorrectly executed repair work, or normal wear and tear.

Flygt assumes no liability for bodily injuries, material damages, or economic losses beyond what is stated above.

**Official approval applies only providing:**

- **that the product is used under conditions described in the care and maintenance instructions and in applications for which it is intended;**
- **that the monitoring equipment incorporated in the product is correctly connected;**
- **that all service and repair work is done by a workshop authorized by Flygt;**
- **that genuine Flygt parts are used.**

Flygt guarantees that a spare parts stock will be kept for 15 years after the manufacture of this product has been discontinued.

The manufacturer reserves the right to alter performance, specification or design without notice.

# DATA PLATE INTERPRETATION

## GENERAL DATA PLATE

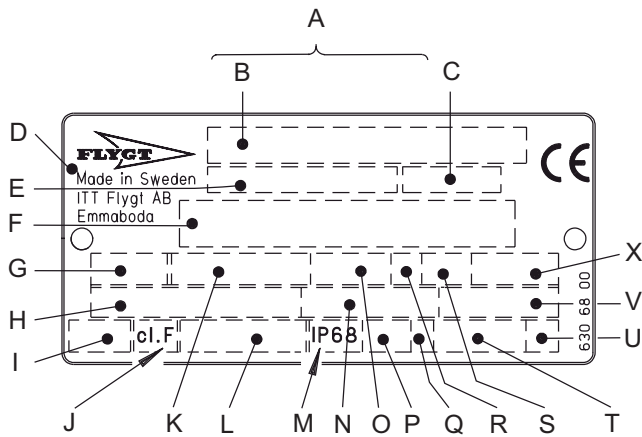

- A Serial number
- B Product code + Number
- C Curve code / Propeller code
- D Country of origin
- E Product number
- F Additional information
- G Phase; Type of current; Frequency
- H Rated voltage
- I Thermal protection
- J Thermal class
- K Rated shaft power
- L International standard
- M Degree of protection
- N Rated current
- O Rated speed
- P Max. submergence
- Q Direction of rotation: L=left, R=right
- R Duty class
- S Duty factor
- T Product weight
- U Locked rotor code letter
- V Power factor
- X Max. ambient temperature

## APPROVAL PLATE

*Always together with the general data plate.*

EN: European Norm

ATEX Directive

EN 50014, EN 50018, EN 1127-1

⊕ II 2 G EEx dII T4

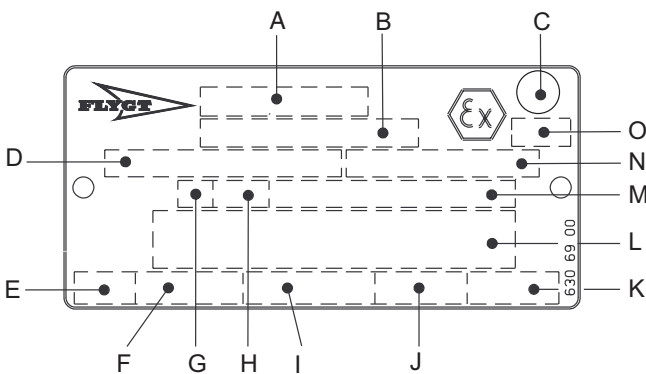

- A Approval
- B Approval authority + Approval Number
- C Approval for Class I,
- D Approved drive unit
- E Stall time
- F Starting current/Rated current
- G Duty class
- H Duty factor
- I Input power
- J Rated speed
- K Controller
- L Additional information
- M Max. ambient temperature
- N Serial Number
- O ATEX marking

# PRODUCT DESCRIPTION

## General Description

These care and maintenance instructions apply to both the standard version and the explosion proof version of the submersible Flygt mixers.

The explosion proof version (Ex-approved) is designed for use in explosive environments in accordance with approval, see page 4.

The submersible mixers 4410 and 4430 have the below features:

- electric motor driven with reduction gearbox
- propellers with different diameters
- different seals
- different installation modes.

**The pH of the liquid:** 6—11.

**Liquid temperature:** max. 40°C (105°F).

**Liquid density:** max. 1100 kg/m<sup>3</sup> (9.2 lb per US gal).

**Depth of immersion:** max. 20 m (65 ft).

min. **4410** 700 mm  
                   350 mm in thick media, very good flow condition or lower motor load.

min. **4430** 800 mm  
                   400 mm in thick media, very good flow condition or lower motor load.

## Applications

4410 and 4430 are intended to be used for:

- mixing and current creation in aeration tanks and lagoons.
- mixing for blending in various liquids.
- current creation in fish farms and for ice prevention.

The mixer is designed for use in many different situations where high flow capacity in relation to power consumption is required.

The mixing effect is dependent upon the density and the viscosity of the liquid and on the volume/shape of the tank.

Mixing of liquids in tank volumes 100—2000 m<sup>3</sup> (26.4—528.5 US gal) per mixer and viscosities up to about 1000 cP.

More than one mixer is required for larger tanks.

For other applications, contact your nearest Flygt representative for information.



Only Ex-approved machines may be used in explosive or flammable environments or for mixing flammable liquids.

## Materials

		Flygt No	EN	ASTM
Cast parts:	Cast iron	0314.	—	A48
		0125.00		No 35B
Propeller:	Fibereinforced polyurethane	0556.	—	—
		9571.50		
Propeller shaft:	Stainless steel	0344.	1.4057	431
		2321.03		
Stand, accessories, screws, nuts and washer:	Stainless steel	0344.	1.4432	316L
		2343.02		
Stand, accessories:	Galvanized steel	0323.	1.0038	A36
		1312.00		
O-rings, Gasket, cable entry:	Nitrile rubber (NBR) 70°IRH (black)	0516.	—	—
		2637.04		
O-rings, Gasket, cable entry:	Fluorinated-rubber (FPM) 70°IRH	0516.	—	—
		2677.32		
Lip seals:	Propeller shaft:	NBR		
	Motor shaft:	FPM		
Mechanical face seals:	Corrosion resistant cemented carbide (WCCR)	0490.8640	—	—

## Weights

Max. weights of the mixer with stand but without motor cable:

4410 215 kg (474 lb)

4430 245 kg (540 lb)

## Motordata 4410

### 50 Hz

2.3 kW,

3 phase, 4 pole,  
1350\* r/min

Voltage V	Rated current A	Starting current A
220	9.7	39
380	5.6	23
400	5.3	22
415	5.1	20
440	4.9	21
500	4.3	15
550	3.9	17
660	3.2	13

0.9 kW

3 phase, 6 pole,  
940\* r/min

Voltage V	Rated current A	Starting current A
220	5.0	19
380	2.9	11
400	2.9	11
415	2.6	10
440	2.7	10
500	2.1	8
550	2.2	8
660	1.7	6

### 60 Hz

2.6 kW (3.5 hp),

3 phase, 4 pole,  
1690\*\* r/min

Voltage V	Rated current A	Starting current A
200	12	51
230	10	42
400	5.8	26
440	5.3	25
460	5.1	24
575	4.0	16

1.1 kW (1.5 hp),

3 phase, 6 pole,  
1135\*\* r/min

Voltage V	Rated current A	Starting current A
200	6.0	21
230	5.4	21
400	3.1	11
440	2.9	13
460	2.9	12
575	2.2	8.1

\* 400 V

\*\* 460 V

1.8 kW (2.4 hp),

1 phase, 4 pole,  
1700 r/min

Voltage V	Rated current A	Starting current A
200	11	48
230	10	48
240	9.8	48

#### Recommended capacitors in single phase operation

1.8 kW (2.4 hp)	220V	230V	240V
Start capacitors	100 uF	100 uF	100 uF
Run capacitors	30 uF	30 uF	28 uF

## Motordata 4430

### 50 Hz

4.0 kW,

3 phase, 4 pole,  
1420\* r/min

Voltage V	Rated current A	Starting current A
190	18	90
220	15	68
380	8.7	39
400	8.3	42
415	8.0	34
440	7.5	37
500	6.6	29
550	6.0	28
660	5.0	23

4.4 kW

3 phase, 2 pole,  
2875\* r/min

Voltage V	Rated current A	Starting current A
190	18	136
220	15	107
380	9.1	60
400	8.6	71
415	8.0	54
440	7.5	58
500	6.6	49
550	6.0	42
660	5.0	35

### 60 Hz

4.6 kW (6.2 hp)

3 phase, 4 pole,  
1715\*\* r/min

Voltage V	Rated current A	Starting current A
230	16	85
240	16	84
260	14	75
380	9.8	50
400	9.4	42
440	8.5	42
460	8.1	40
575	6.5	29

\* 400 V

\*\* 460 V

2.9 kW (3.9 hp)

1 phase, 4 pole,  
1700 r/min

Voltage V	Rated current A	Starting current A
220	17	47
230	16	51
240	15	55

#### Recommended capacitors in single phase operation

2.9 kW (3.9 hp)	220V	230V	240V
Start capacitors	130 uF	120 uF	115 uF
Run capacitors	50 uF	45 uF	40 uF

## Design

40056

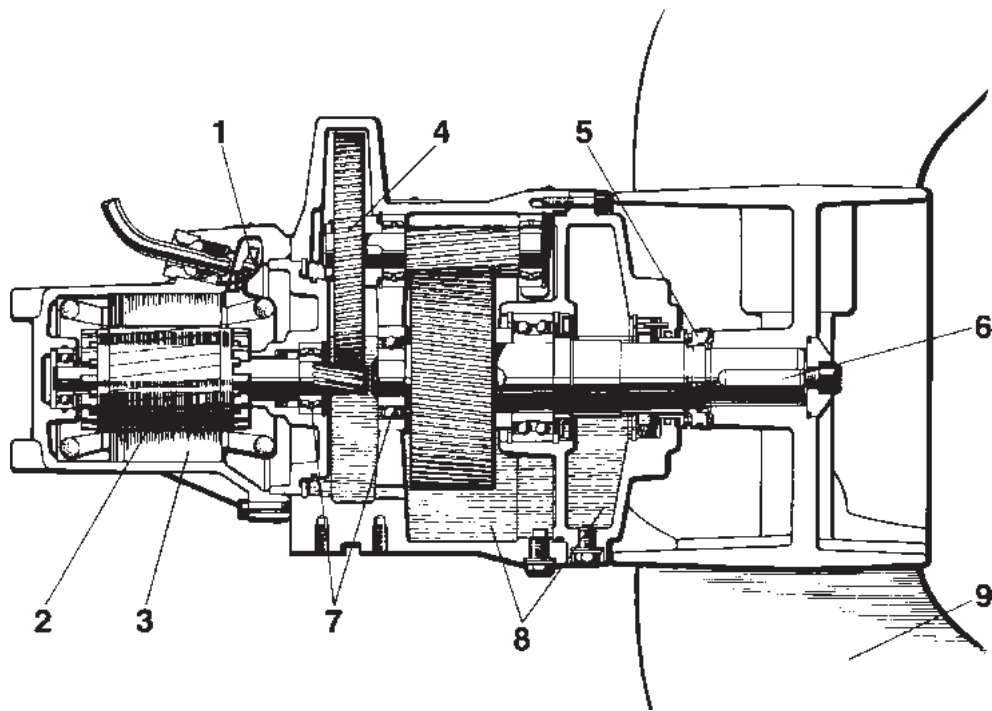

### 1. Junction box

The junction box is completely sealed off from the surrounding liquid.

### 2. Motor

Squirrel-cage 3-phase induction motor for 50 Hz or 60 Hz.

The motor is started by means of direct on-line or star-delta start.

The motor can be run continuously or intermittently with a maximum of 15 evenly spaced starts per hour.

The stator is insulated in accordance with class F (155°C, 310°F). The motor is designed to supply its rated output at  $\pm 5\%$  variation of the rated voltage. Without overheating the motor,  $\pm 10\%$  variation of the rated voltage can be accepted provided that the motor does not run continuously at full load. The motor is designed to operate with a voltage imbalance of up to 2% between the phases.

### Cooling

The stator is cooled by the surrounding liquid.

### 3. Monitoring equipment

The stator incorporates three thermal contacts connected in series.

The thermal contacts open at 125°C (260°F).

See also "Electrical connections" and separate instructions for starter equipment.

The machine can be equipped with a sensor, CLS for sensing water in the oil. The sensor is not applicable for Ex-approved machines.

### 4. Gear unit

The gear unit is a two-stage shaft-mounted gear with helical teeth.

The gear unit is calculated in accordance with ISO and AGMA for more than 100 000 hours of operation, continuous duty.

### 5. Shaft seals

The mixer has one mechanical seal and two lip seals.

### 6. Shafts

The motor shaft is delivered with the rotor as an integral part.

The propeller shaft is completely sealed off and will not come in contact with the liquid.

### 7. Bearings

The motor shaft bearing consists of a single-row, deep groove ball bearing as support bearing and a double-row spherical roller bearing as main bearing.

The counter shaft is carried in two spherical roller bearings.

The propeller shaft is carried in a double-row angular contact ball bearing as inner bearing and a single-row cylindrical roller bearing as outer bearing.

The bearings are calculated for more than 100 000 for 4/6 pole and 50 000 hours of operation for 2 poles (L10aa).

### 8. Oil casing

The oil lubricates and cools the seals, bearings, gears and acts as an additional barrier against penetrating liquid.

Pressure build-up within the oil casing is reduced by means of a built-in air volume.

### 9. Propeller

The propeller is two-bladed and backward curved to prevent clogging.

It is available in the following diameters: 1400, 1500, 1600, 1700, 1800, 2000, 2200 and 2500 mm (55.1, 59.0, 63.0, 66.9, 70.1, 78.7, 86.6 and 98.5").

The propeller is designed for optimum reacting force and flow in relation to power input.

## Possible combinations and performance data for 4410

Motor	Propeller diameter mm	Reduction								
		56.64	52.71	48.30	44.96	40.81	36.39	34.80	31.04	
50 Hz 2.3 kW 3 Phase 4-pole	2500 2200 2000 1800 1700 1600 1500 1400	25	27	29	31	34	38	40	45	Speed rpm
		1.55	1.79	2.19	2.55	-	-	-	-	Power input kW
		1.35	1.57	1.94	2.31	-	-	-	-	
		1.14	1.35	1.66	1.95	2.47	-	-	-	
		0.92	1.09	1.35	1.60	2.00	2.71	-	-	
		0.84	0.99	1.24	1.46	1.81	2.44	2.71	-	
		0.76	0.90	1.10	1.31	1.63	2.15	2.50	-	
		0.68	0.80	0.98	1.15	1.45	1.89	2.16	-	
		0.61	0.70	0.85	0.90	1.24	1.60	1.80	2.38	
50 Hz 0.9 kW 3 Phase 6-pole	2500 2200 2000 1800 1700 1600 1500 1400	17	18	19	21	23	26	Speed rpm		
		0.80	0.89	1.05	-	-	-	Power input kW		
		0.67	0.78	0.89	1.03	-	-			
		0.60	0.68	0.80	0.91	1.07	-			
		0.53	0.59	0.68	0.77	0.89	1.10			
		0.50	0.56	0.65	0.72	0.83	1.02			
		0.48	0.53	0.60	0.66	0.78	0.93			
		0.46	0.49	0.56	0.61	0.71	0.83			
		0.44	0.46	0.51	0.57	0.65	0.73			
60 Hz 2.6 kW (3.5 hp) 3 Phase 4-pole	2500 2200 2000 1800 1700 1600 1500 1400	30	32	35	38	42	47	Speed rpm		
		2.39	2.75	-	-	-	-	Power input kW		
		2.14	2.50	-	-	-	-			
		1.81	2.14	2.63	-	-	-			
		1.46	1.71	2.17	2.57	-	-			
		1.33	1.55	1.97	2.34	2.94	-			
		1.24	1.40	1.75	2.06	2.61	-			
		1.09	1.25	1.54	1.80	2.30	-			
		0.97	1.10	1.31	1.50	1.92	2.80			
60 Hz 1.1 kW (1.5 hp) 3 Phase 6-pole	2500 2200 2000 1800 1700 1600 1500 1400	20	21	23	25	Speed rpm				
		1.03	1.20	-	-	Power input kW				
		0.87	1.03	1.20	-					
		0.76	0.90	1.04	1.18					
		0.64	0.74	0.87	0.98					
		0-60	0.69	0.80	0.90					
		0.56	0.63	0.74	0.82					
		0.51	0.68	0.67	0.73					
	0.48	0.53	0.60	0.64						
60 Hz 1.8 kW (2.4 hp) 1 Phase 4-pole	2000 1800 1700 1600 1500 1400	30	32	35	38	42	Speed rpm			
		1.81	-	-	-	-	Power input kW			
		1.46	1.71	-	-	-				
		1.33	1.55	1.97	-	-				
		1.24	1.40	1.75	-	-				
		1.09	1.25	1.54	1.80	-				
		0.97	1.10	1.31	1.50	1.92				



**Possible combinations and performance data for 4430.**

Motor	Propeller diameter mm	Reduction								
		56.64	52.71	48.30	44.96	40.81	36.39	34.80	31.04	
<b>50 Hz</b> 4.0 kW 3 Phase 4-pole	2500	<b>25</b>	<b>27</b>	<b>30</b>	<b>32</b>	<b>35</b>	<b>40</b>	<b>41</b>	<b>46</b>	<b>Speed rpm</b>
	2200	1.65	1.90	2.31	2.69	3.42	-	-	-	<b>Power input kW</b>
	2000	1.43	1.67	2.05	2.43	3.11	4.12	-	-	
	1800	1.23	1.42	1.74	2.06	2.62	3.56	3.96	-	
	1700	1.03	1.17	1.42	1.68	2.11	2.85	3.22	-	
	1600	0.96	1.08	1.30	1.53	1.91	2.57	2.87	3.95	
	1500	0.88	0.98	1.18	1.38	1.71	2.28	2.53	3.49	
	1400	0.80	0.89	1.05	1.22	1.51	1.98	2.19	3.00	
1400	0.72	0.79	0.92	1.06	1.31	1.68	1.85	2.50		
<b>50 Hz</b> 4.4 kW 3 Phase 2-pole	1600	<b>50</b>	<b>54</b>	<b>Speed rpm</b>						
	1500	4.52	-	<b>Power input kW</b>						
	1400	3.93	4.77							
<b>60 Hz</b> 4.6 kW (6.2 hp) 3 Phase 4-pole	2500	<b>25</b>	<b>30</b>	<b>35</b>	<b>38</b>	<b>42</b>	<b>47</b>	<b>49</b>	<b>55</b>	<b>Speed rpm</b>
	2200	2.44	2.89	3.57	4.20	-	-	-	-	<b>Power input kW</b>
	2000	2.20	2.61	3.24	3.88	4.94	-	-	-	
	1800	1.89	2.21	2.75	3.29	4.17	-	-	-	
	1700	1.56	1.81	2.25	2.65	3.42	4.67	-	-	
	1600	1.44	1.67	2.05	2.40	3.07	4.20	4.75	-	
	1500	1.32	1.52	1.85	2.14	2.72	3.72	4.21	-	
	1400	1.18	1.36	1.64	1.90	2.37	3.21	3.63	4.95	
1400	1.04	1.19	1.43	1.65	2.01	2.69	3.05	4.16		
<b>60 Hz</b> 2.9 kW (3.6 hp) 1 Phase 4-pole	2500	<b>30</b>	<b>32</b>	<b>35</b>	<b>38</b>	<b>42</b>	<b>47</b>	<b>49</b>	<b>Speed rpm</b>	
	2200	2.44	2.89	-	-	-	-	-	-	<b>Power input kW</b>
	2000	2.20	2.61	-	-	-	-	-	-	
	1800	1.89	2.21	2.75	-	-	-	-	-	
	1700	1.56	1.81	2.25	2.65	-	-	-	-	
	1600	1.44	1.67	2.05	2.40	3.07	-	-	-	
	1500	1.32	1.52	1.85	2.14	2.72	-	-	-	
	1400	1.18	1.36	1.64	1.90	2.37	-	-	-	
1400	1.04	1.19	1.43	1.65	2.01	2.69	3.05	-		

# TRANSPORTATION AND STORAGE

The mixer must be transported and stored in a vertical or horizontal position. Make sure that it can't roll or fall over.

The propeller blades should be packed separately.



**Always lift the machine by the lifting device, never by the motor cable.**

For a longer periods of storage, the mixer must be protected against moisture and heat. Remove the propeller blades and the hub. Grease the end of the

shaft with molybdenum disulfide or an equivalent grease. Treat all other untreated surfaces with oil.

Undo the cable entry to prevent the motor cable from being deformed. The propeller shaft should be rotated by hand occasionally (for example, every other month) to prevent the seals from sticking together. If the mixer is stored for more than 6 months, this rotating is mandatory.

After a long period of storage, the mixer should be inspected before it is put into operation. Pay special attention to the seals and the cable entry

Follow instructions under the heading "Before starting".

# INSTALLATION



**Ex-version!  
Installation of the explosion-proof mixer must be performed by authorized personnel.**

## Safety precautions

In order to minimize the risk of accidents in connection with the service and installation work, the following rules should be followed:

1. Never work alone. Use a lifting harness (part No. 84 33 02), a safety line (part No. 84 33 03) and a respirator (part No. 84 33 01), as required. Do not ignore the risk of drowning!
2. Make sure that there is sufficient oxygen and that there are no poisonous gases present.
3. Check the explosion risk before welding or using electric hand tools.
4. Do not ignore health hazards. Observe strict cleanliness.
5. Bear in mind the risk of electrical accidents.
6. Make sure that the lifting equipment is in good condition.
7. Provide a suitable barrier around the work area, for example a guard rail.
8. Make sure that you have a clear path of retreat!
9. Use a safety helmet, safety goggles and protective shoes.
10. All personnel who work with sewage systems should be vaccinated against diseases that can occur.
11. A first-aid kit must be handy.

Follow all other health and safety rules and local codes and practices.



**If persons are likely to come into physical contact with the machine or mixed/pumped media (liquid) the earthed (grounded) socket must have an additional earth-(ground)-fault protection device (GFI) connected.**



**In order to avoid accidents, warning signs, for rotating propellers and machines that start automatically must be positioned visibly. The area in the proximity of the machines should be fenced off.**



**For some installations and at certain operating points on the performance curve the noise level 70 dB or the noise level specified for the actual machine can be exceeded.**

## NOTE!

**The machine including the blades should always work completely submerged in the liquid.**



**To reduce the risk of electric shock, see chapter "Installation" and "Electrical connections".**

**The tank of a sewage machine station must be vented in accordance with local plumbing codes.**

**The machine is not to be installed in locations classified as hazardous in accordance with the national electric code, ANSI/NFPA 70-1990.**

## CAUTION!

**This machine is intended to run fully submerged. Level sensing equipment should be installed if there is a possibility that the machine could be operated at less than the "minimum submergence depth".**

## Handling equipment

Lifting equipment is required for handling the mixer.

The lifting device should not have a lifting capacity which is greater than twice the weight of the mixer.

Oversized lifting equipment could cause damage if the mixer gets stuck when being lifted.

Make sure that the lifting equipment is securely anchored.



**Always lift the machine by the lifting device, never by the motor cable.**

**Keep out from suspended loads.**

**Make sure that the machine (or parts of the machine) can't roll or fall over and injure people or damage property.**

## Installation alternatives

The mixer should be installed in an empty tank.

Flygt supplies equipment for a moveable mode of installation. The mixer can also be installed on rigid structures, pillars, stands, gratings, on an anchored raft etc.

For all installations, keep in mind the reaction force of the mixer, which can be up to 3500 N.

Avoid installations where:

- there are obstacles in front of the mixer,
- the flow on the suction side of the mixer is obstructed due to the design of the tank.

This is an absolute requirement for continuously operating mixers.

Run the cables so that they do not have any sharp bends and are not pinched.

NOTE! The end of the cable may not be submerged. Leads must be above flood level, as water may penetrate through the cable into the junction box or the motor.

### NOTE!

**In all installations, make sure that the motor cable can't be drawn into the propeller.**

Test always that the mixer will go easily up and down on the guide bar, before the mixer has been lowered to the desired working depth.

### NOTE!

**Don't position the mixer during when it is operating.**

Consult your nearest Flygt representative regarding:

- choice of peripheral equipment.
- other problems in connection with installation.

In connection with the installation work, the following **minimum** distances should be observed;

- The distance between the peak position of the propeller blade and the bottom of the tank and/or the side wall should **not be less than 300 mm (11.8")**.
- The distance between the peak position of the propeller blade and the liquid level should normally **not be less than 800 mm (31.4")**. In thick media and very good flow condition or lower motor load, the distance between the peak position of the propeller and the liquid level can be 300 mm (12") not less.
- The distance between the propeller and the background wall should **not be less than the dimension of the propeller diameter**.

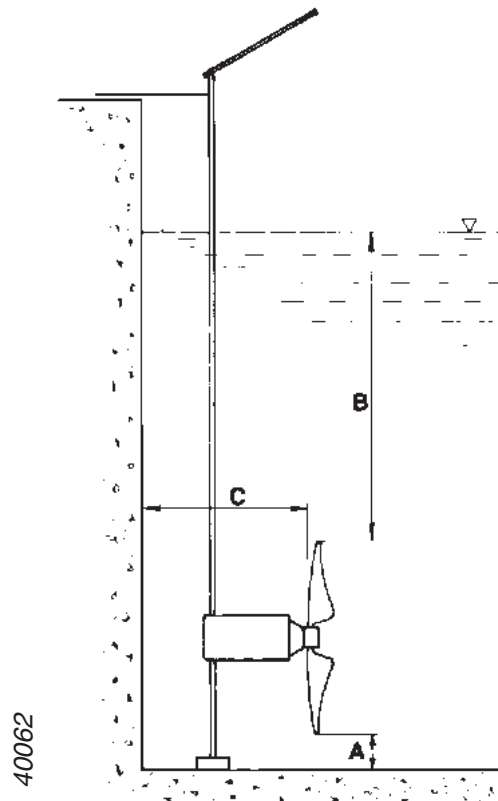

Note; When using support, check that mixer unit is resting firmly against support.

The wire must be kept tense enough so that the mixer stays firmly in place.

# ELECTRICAL CONNECTIONS



## Ex-version

Electrical connections of the explosion-proof mixer must be performed by authorized personnel.



Before starting work on the machine, make sure that the machine is isolated from the power supply and can't be energized.

All electrical equipment must be earthed (grounded). This applies to both the machine and any control or monitoring equipment.

Failure to heed this warning may cause a lethal accident. Make sure that the earth lead is correctly connected by testing it.

Flygt disclaims all responsibility for work done by untrained, unauthorized personnel.

All electrical work shall be carried out under the supervision of an authorized electrician.

Local codes and regulations must be observed.

Check that the voltage and frequency on the data plate agree with your actual power supply.

The motor can be connected for different voltages as shown on the data plate.

If intermittent operation is prescribed (see data plate), the mixer should be provided with control equipment that provides such operation.

Under no circumstances may the starting equipment be installed in direct connection with the tank.

To avoid leakage into the mixer, check:

- that the cable entry seal sleeve and washers conform to the outside diameter of the cable. See the parts list.
- that the outer sheath on the cable is not damaged. When refitting a cable which has been used before, **always** cut off a short piece of the cable so that the cable entry sleeve does not seal onto the cable at the same point again.



For safety reasons, the earth lead should be longer than the phase leads 50 mm (2.0") for 4410 and 70 mm (2.8") for 4430. If the motor cable is jerked loose by mistake the earth lead should be the last to come loose from its terminal. This applies to both ends of the cable.

With long cables, the voltage drop must be taken into consideration, since the motor's rated voltage is the voltage measured at the terminal board in the mixer.

The cables are fragile, beware that no sharp bends occur during installation procedures especially at the entrance flange.

Make sure that the mixer is correctly earthed (grounded).

Available motor cables are SUBCAB® or SUBCAB® AWG.

Connect the motor cable to the terminal board as illustrated in the figure.

Connect the leads from the motor control circuit to T1 and T2.

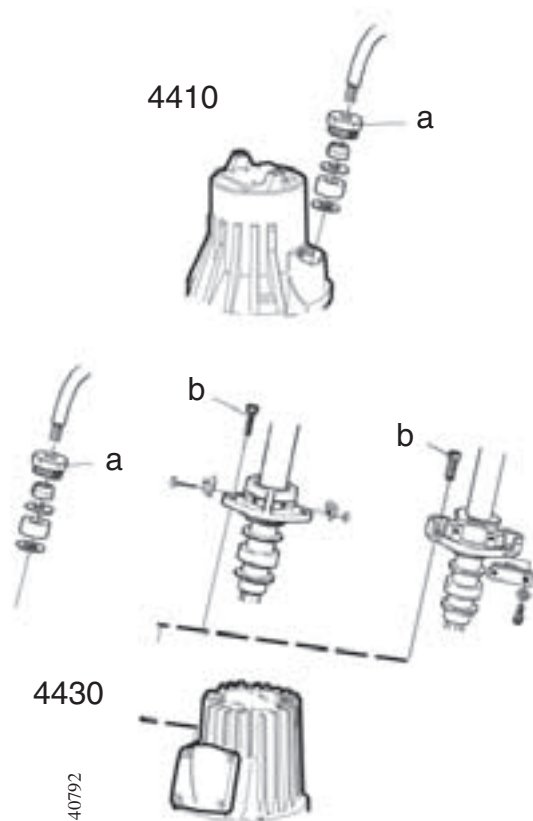

Tighten the gland nut (a) or the screws (b) so that the cable entry unit forms an effective seal.

Connect the motor cable to the starter equipment. Check the direction of rotation, see "Before starting".

If the direction of rotation is wrong, transpose two of the phase leads.

Check on the data plate which connection, Y or  $\Delta$ , is valid for the voltage supply. Then, depending on voltage, arrange the connection on the terminal board in accordance with Y or  $\Delta$ .

Remember that the starting surge with the direct-on-line start can be up to six times higher than the rated current. Make sure that the fuses or circuit breakers are of the proper amperage.

Fuse ampere and cable must be selected in accordance with local rules and regulations.

The table (see "Product Description") gives rated current and starting current. Fuse amperage and cable must be selected in accordance with local rules and regulations.

The overload protection (motor protection breaker) must be set to the motor's rated current as given on the data plate.

With a clockwise phase sequence L1-L2-L3 (R-S-T), the propeller will rotate correctly, i.e. clockwise as viewed from the motor side. Check the phase sequence in the main (line) using a phase sequence indicator.

Three thermal contacts are incorporated in the stator and are normally closed. The thermal contacts can be connected to maximum of 250 volts, breaking of 4 amps. current at maximum.

Connect the thermal contacts to the starter.

**CAUTION!**

**If the machine is intended for use with a Variable frequency drive (VFD), be careful in choosing motor cable. The VFD might demand a screened cable.**

**Please read the manufacturer's instruction for the VFD.**

**For additional assistance, contact your ITT Flygt representative.**



**Thermal contacts must be used on Ex-approved machine due to approval conditions.**

## Connection of the stator leads and the motor cable

Connect the stator leads and the motor cable as shown in the wiring diagrams.

### Stator leads

Stator leads	Connection terminal board
red	U1, U5
brown	V1, V5
yellow	W1, W5
green	U2, U6
blue	V2, V6
black	W2, W6

## Cable chart

Conductors	Connection	
	starter	terminal board

### SUBCAB® 4Gx+2x1,5 for direct on line start

brown	L1	U1
blue	L2	W1
black	L3	V1
yellow/green	earth	earth
black T1	T1*	T1*
black T2	T2*	T1*

### SUBCAB® xAWG/7 for direct on line start

red	L1	U1
white	L2	W1
black	L3	V1
yellow	GC**	GC**
yellow/green	earth	earth
orange	T1*	T1*
blue	T2*	T2*

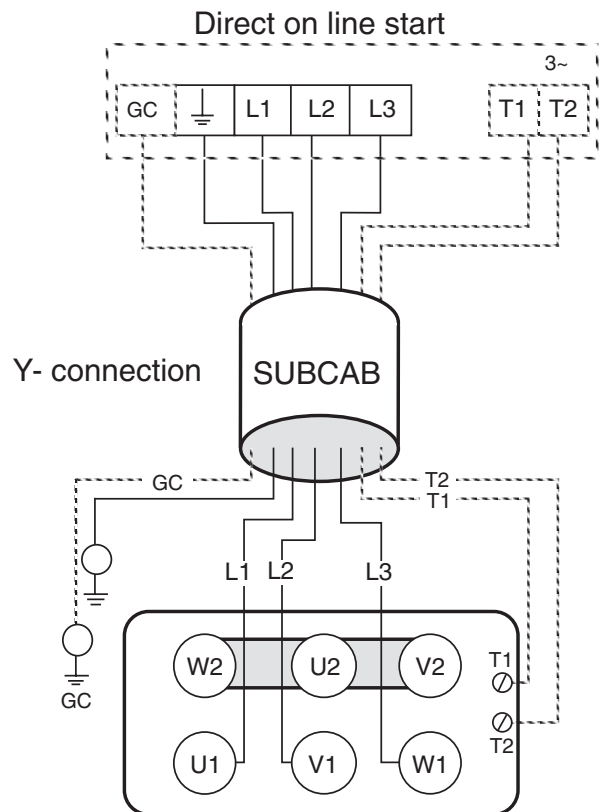
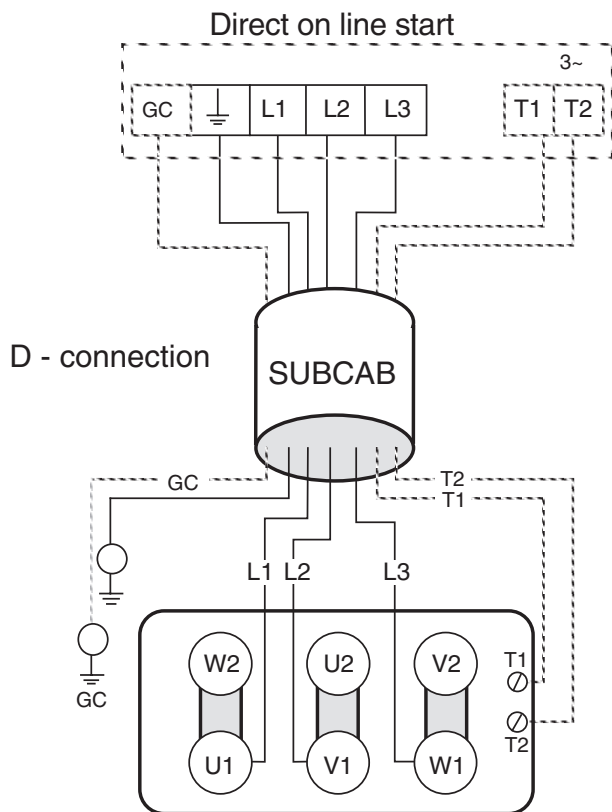

Leads not in use must be isolated.

Conductors	Connection	
	starter	terminal board

**SUBCAB® 7Gx+2x1,5 for Y/Δ start**

black 1	L1	U1
black 2	L2	W1
black 3	L3	V1
black 4	L1	W2
black 5	L2	U2
black 6	L3	V2
yellow/green	earth	earth
black T1	T1*	T1*
black T2	T2*	T2*

\* Terminal for connection of thermal switches in motor and monitoring equipment.

\*\* GC = Ground Check

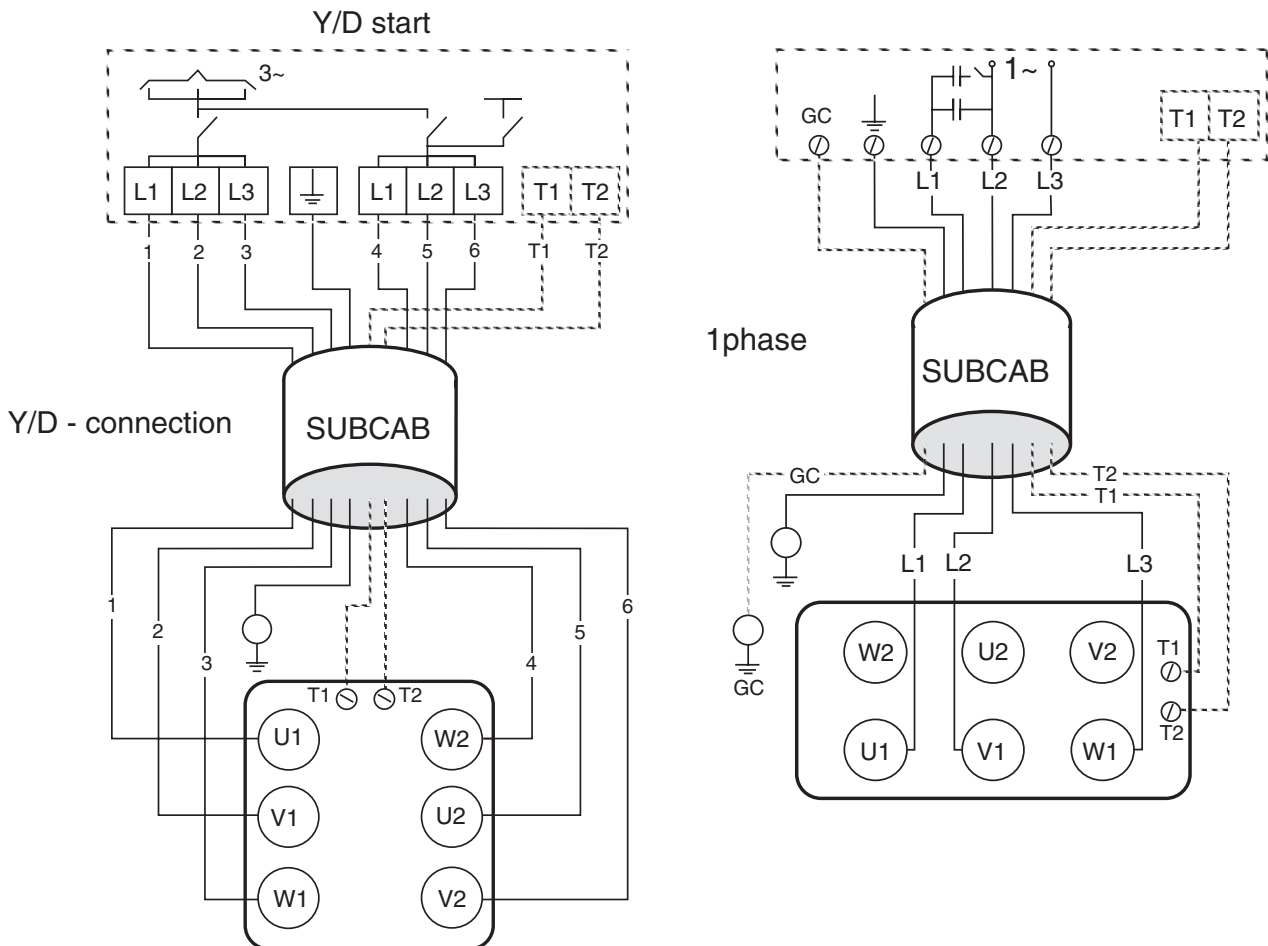

**Leads not in use must be isolated.**

## Monitoring equipment

**NOTE!**

**Make sure that the monitoring equipment incorporated in the product is correctly connected.**

### Capacitive leakage sensor CLS-30.

The machine is available with leakage sensors for sensing water in the oil casing.

A plate in the junction box shows that the machine is equipped with sensors.

**The CLS-30 sensor is not applicable to Ex-approved machines.**

CLS-30 is a leakage sensor for sensing water in the oil casing and issues an alarm when the oil contains 10% water. Oil change is recommended within 14 days of alarm. If the sensor issues an alarm shortly after the oil is changed, contact your nearest Flygt representative.

The CLS-30 sensor is installed in the bearing housing and goes down into the oil casing.

The sensor is connected in series with the stator's thermal contacts. They are connected on installation to an alarm relay, type MiniCAS, in accordance with the following diagram.



**Observe that the CLS cover is made of glass and can thus cause personal injury.**

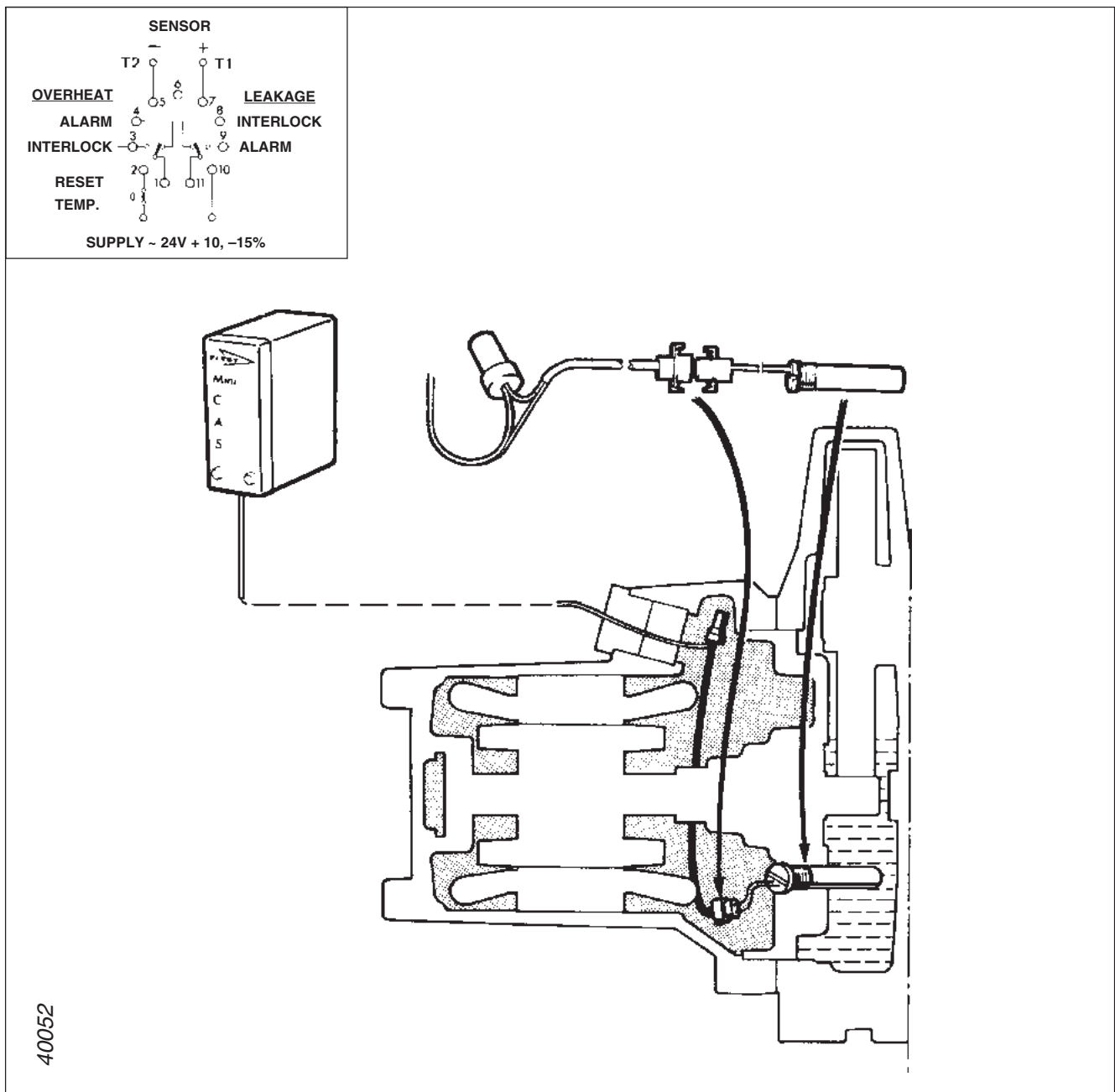



# OPERATION

## Before starting

Check the oil level in the oil casing and in the gear box housing.

Remove the fuses or open the circuit breaker and check that the propeller can be rotated by hand.

Check that the cable entry is securely tightened.

Check that the monitoring equipment (if any) works.

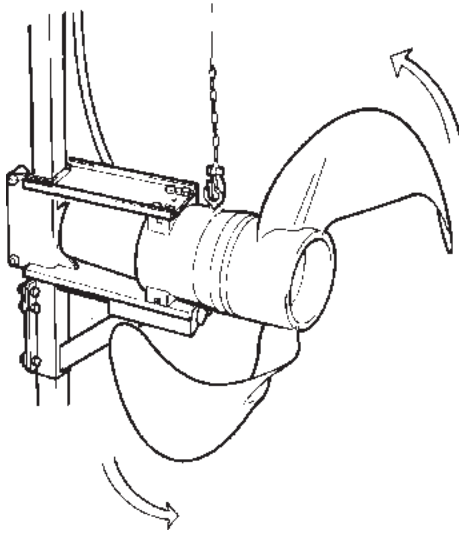

The machine shall be fixed to the guide bar during test starting.

Check the direction of rotation. See the figure. The propeller should rotate clockwise, as viewed from the motor side.



**Watch out for the propeller and for the starting jerk, which can be powerful.**

## During operation

Test-run the mixer and note the current surge during start-up. At the instant of starting, it is normal for the current to exceed the operating current by 10—20 % for a few seconds. The steady-state current should be less than the rated current.

Excessive current consumption may be caused by high viscosity or density of the liquid or an improperly adjusted mixer.

Check that the mixer does not vibrate. Vibration can occur when mixing is too vigorous in a small tank volume, or by air sucked down by the propeller. Vibration can also occur due to interference between several mixers.

Adjust and try another operating direction for the mixer.

Make sure that the distance between the peak position of the propeller blade and the liquid level is right, see point B in “Installation alternatives”.

In continuous operation, air must not be drawn down by the propeller (a vortex may not form).



**Watch out for the propeller in rotation.**

# CARE AND MAINTENANCE

The numbers in parentheses are item numbers and refer to the exploded view on the inside cover.

## Safety precautions



**Before starting work on the mixer, make sure that the mixer is isolated from the power supply and can't be energized.**

To prevent injury watch out for damaged and worn parts.

NOTE! This applies to the control circuit as well.

The following points are important in connection with work on the mixer:

- make sure that the mixer has been thoroughly cleaned.
- observe good personal hygiene.
- beware of risk of infection.
- follow local safety regulations.

The mixer is designed for use in liquids which can be hazardous to health. In order to prevent injury to the eyes and skin, observe the following points when working on the mixer:

- always wear goggles and rubber gloves.
- rinse the mixer thoroughly with clean water before starting work.
- rinse the components in water after disassembly.
- hold a rag over the oil casing screw (58) when removing it. Otherwise, pressure that may have built up in the mixer may cause splatter into the eyes or onto the skin.

Proceed as follows if you get hazardous chemicals in your eyes:

- rinse immediately in running water for 15 minutes. Hold your eyelids apart with your fingers.
- contact an eye doctor.

on your skin:

- remove contaminated clothes.
- wash skin with soap and water.
- seek medical attention if required.



**Do not ignore the risk of accidents. Make sure that the machine (or parts of the machine) can't fall over.**

## Service



**NOTE for Ex-approved machine**  
**All work on the explosion-proof motor section must be performed by personnel authorized by Flygt.**  
**Flygt disclaims all responsibility for work done by untrained, unauthorized personnel.**

Regular inspection and preventive maintenance ensure more reliable operation.

The gear casing's oil should be checked and changed if it is contaminated and the oil screw's magnetic plug should be cleaned after 200 hours of operation.

The mixer should be inspected after 8000 hours of operation or at least once a year.

Under normal operating conditions, the mixer should have a major overhaul in a service shop every third year, once a year under severe operating conditions.

This requires special tools and should be done by an authorized service shop.

When the mixer is new or when the seals have been replaced, inspection is recommended after one week of operation.

## Inspection

Inspection involve that following will be checked and measured if required;

- replacement of all worn component.
- check all screw connections.
- check quantity and condition of the oil.
- check if there is liquid in the stator casing.
- check the cable entry and condition of the cable.
- functional check of the start equipment.
- functional check of monitoring equipment.
- check of direction of rotation.
- check the lifting device and guide bars (clearance and wear).
- check of electrical insulation.
- replace all O-rings which were removed for inspection.
- check and rinse the space around the seals.  
See also "Recommended inspection".

## Workshop overhaul

This requires special tools and should be done by an authorized service shop. Workshop overhaul involves in addition to the inspection, that the following will be measured;

- replacement of bearing.
- replacement of shaft seals.
- replacement of oil.
- replacement of O-rings.
- replacement of seals in cable entry and moving the entry position of the cable.
- replacement of cable.

## Service contract

Flygt or its agent normally offers service agreements in accordance with a preventive maintenance plan. For further information, please contact your Flygt representative.

## Recommended inspections

Inspection of	Action
Visible parts on mixer and installation	<p>Replace or fix worn and damaged parts.</p> <p>Make sure that all screws, bolts and nuts are tight.</p> <p>Check the condition of lifting device/lifting eyes, chains and wire ropes.</p> <p>Check that the guide bar is vertical.</p> <p>Replace worn parts if they impair function.</p>

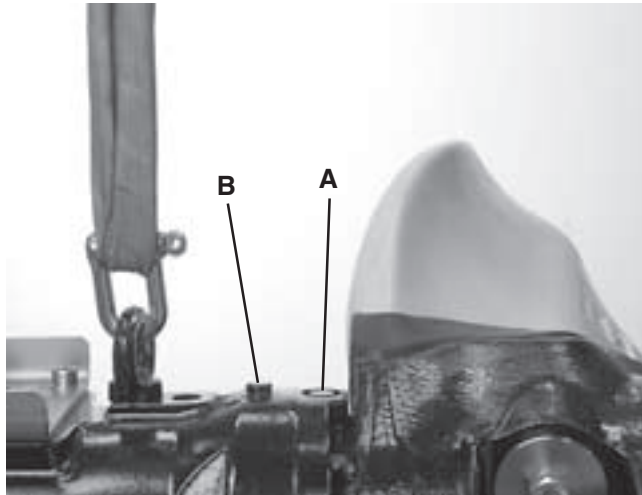

Oil quantity	<p><b>Oil casing (A) and gear unit (B)</b></p> <p><b>WARNING.</b> If the seal leaks, the oil casing may be under pressure. Hold a rag over the oil casing screw in order to prevent splatter. See “Safety precautions” for additional information.</p> <p>Check the oil quantity. The oil level should be ~ 120 mm (~ 4.7”) from the top of the oil hole.</p> <p>Add oil as needed. See “Changing the oil”.</p>
Condition of the oil	<p>A check of the condition of the oil can show whether there has been an increased leakage.</p> <p>Insert a tube (or hose) into the oil hole. Cover the top end of the tube and take up a little oil from the bottom.</p> <p>Change the oil if it contains too much water, see “Changing the oil”. Check again one week after changing the oil. NOTE! The oil in the gear unit is not allowed to contain any water.</p> <p>If the oil contains too much water again, the fault may be:</p> <ul style="list-style-type: none"><li>— that an oil screw is not sufficiently tight.</li><li>— that the O-ring of an oil screw or its sealing surface is damaged.</li><li>— that an O-ring or its sealing surface is damaged.</li><li>— that the outer mechanical seal is damaged.</li></ul> <p>Contact a Flygt service shop.</p> <p>Change the gear oil if it contains metallic particles or water.</p> <p>Even if the mixer is equipped with a water in oil sensor (CLS) is it recommended to check the oil periodically.</p>

Inspection of	Action
Liquid in the stator casing	<p><b>WARNING.</b> If there has been leakage, the stator casing may be under pressure. Hold a rag over the inspection screw to prevent splatter. See “Safety precautions” for additional information.</p> <p>Suspend the mixer horizontally from an overhead crane.</p> <p>Loosen the screws.</p> <p>If there is water in the stator casing, the cause may be:</p> <ul style="list-style-type: none"> <li>— that an O-ring is damaged.</li> <li>— that the cable entry is leaking.</li> </ul> <p>If there is oil in the stator casing, the cause may be:</p> <ul style="list-style-type: none"> <li>— that the inner lip seal is damaged.</li> </ul> <p>Contact a Flygt service shop.</p>
Cable entry	<p>Make sure that the cable entry is tight.</p> <p>If the cable entry leaks:</p> <ul style="list-style-type: none"> <li>— check that the entry is tightened and forms an effective seal.</li> <li>— cut a piece of the cable off so that the seal sleeves seals onto a new position on the cable.</li> <li>— replace the seal sleeves.</li> <li>— check that the seal sleeves and the washers, conform to the outside diameter of the cable.</li> </ul>
Cable	<p>Replace the cable if the outer sheath is damaged.</p> <p>Make sure that the cables do not have any sharp bends and are not pinched.</p>
Starter equipment	<p>If starter equipment is faulty, contact an electrician.</p>
Monitoring equipment (should be checked often)	<p>Follow the instructions for monitoring equipment.</p> <p>Check:</p> <ul style="list-style-type: none"> <li>— signals and tripping function.</li> <li>— that relays, lamps, fuses and connections are intact.</li> </ul> <p>Replace defective equipment.</p>
Rotation direction of mixer (requires voltage)	<p>Transpose two phase leads if the propeller does not rotate clockwise as viewed from the motor side. Rotation in the wrong direction reduces the capacity of the mixer and the motor may be overloaded. Check the direction of rotation every time the mixer is reconnected.</p>
Guide bar and other peripheral equipment	<p>Repair faults and notify supervisor of any faults or defects.</p>
Insulation resistance in the stator	<p>Use an insulation tester. With a 1000 V-DC megger the insulation between the phases and between any phase and earth (ground) should <b>not be less</b> than 1 MΩ.</p>

## Changing the oil

Suspend the mixer horizontally from an overhead crane.



**The oil casing may be under pressure. Hold a rag over the oil plug to prevent splatter.**

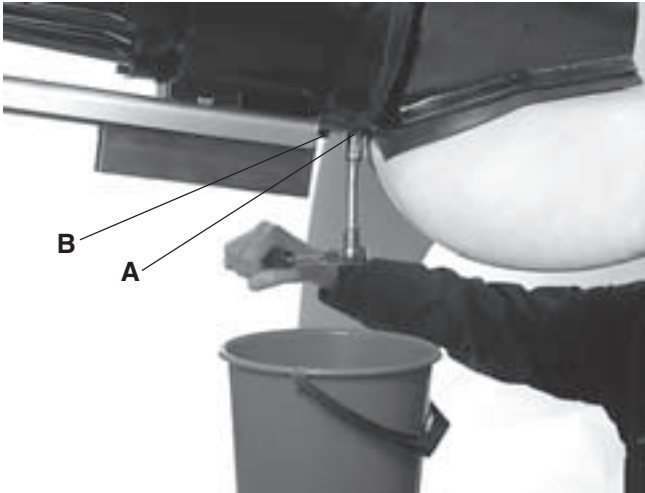

### Oil casing (A)

Unscrew the oil draining screw.

It is easier to drain the oil if the oil filling hole screw also is removed.

Replace the O-ring and put the lower oil screw back and tighten it.

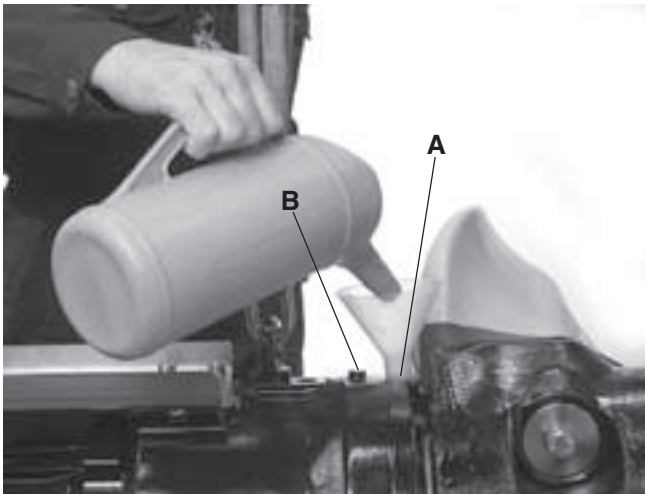

Fill the oil casing (A) with 1.5 litre (0.4 US gal) new oil. Always replace the O-rings of the oil hole screws. Put the screw back and tighten it. Tightening torque for the oil screws are 10—20 Nm (7.4—15 ft lb).

The mixers oil casing is delivered from factory with a tasteless and odourless paraffin oil suitable for raw or clean-water applications.

This oil is authorized according to FDA 172.878, (FDA = Food and Drug Administration authority in US).

We recommended that Mobil Whiterex or Shell Ondina, with viscosity class ISO VG15 to 32, be used.

In media where paraffin oil is not required, a mineral oil, i.e. compressor oil or hydraulic oil with (the same) viscosity class VG15 to 32, should be used. Regular motor oil type SAE 5(W) up to SAE 25(W) can also be used.

### Gear unit (B)

It is easier to drain the oil if the oil filling hole screw is also removed.

Replace the O-ring and put the gear housing oil screw back.

Fill the gear unit (B) with 5 l (1.32 US gal) new oil. Flygt recommended to use Mobil gear SHC 630 or similar syntetic oil. Always replace the O-ring of the oil hole screw. Put the screw back and tighten it.

Tightening torque for all oil screws is 10—20 Nm (7.4—15 ft lb).

## Removing the propeller blades



Undo the screw, remove it and the washers and the o-ring.



Tap a mandrell carefully with a mallet until the blade comes out of its slot. Then twist the blade backwards and forwards so that the propellerblade comes loose from the hub.

Do the same with the other blade.

## Removing the propeller hub



Place the mixer on a workbench and secure it. Fit a sling to the hub (use the bladeshaft's hole) and slacken it a little.

Remove the hub screw, the washer, the o-ring and the sleeve.



Attach a puller (art No 84 20 49) combined with three jaws (art No 84 14 45) to the hub and pull it out supported in the sling.



## Fitting the propeller hub

Place the mixer on a workbench and secure it.



Make sure that the end of the shaft is clean and free of burrs. Polish off any flaws with fine emery cloth. Grease the end of the shaft.

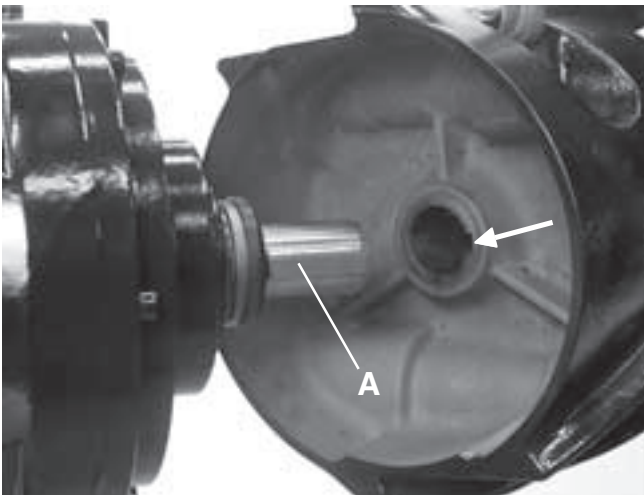

Fit the shaft key (a).

Turn the shaft so the key corresponds with the groove in the hub.

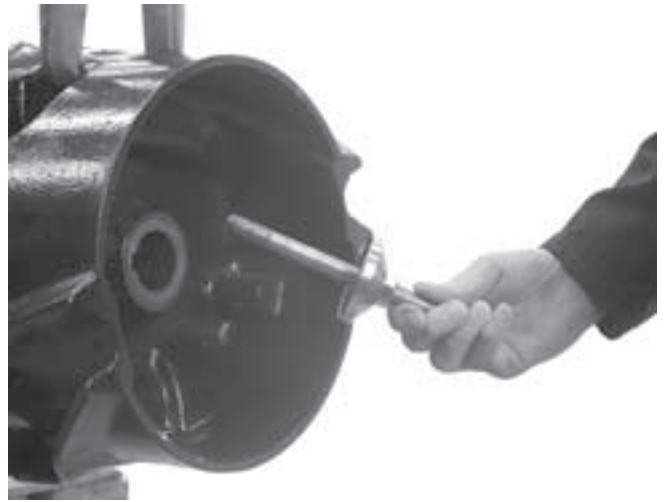

Press the hub onto the shaft with a stud bolt (M16×170), a nut (M16) and the washer – supported in the sling.

Use the stud bolt and a nut from the assembling tool 5876100 as a mounting screw.



Continue to press the hub onto the shaft. Remove the mounting screw.



Place the sleeve, o-ring and washer on the hub screw and tighten it.

Tightening torque 140 Nm.

Check that the hub can be rotated by hand.

## Fitting the propeller blades

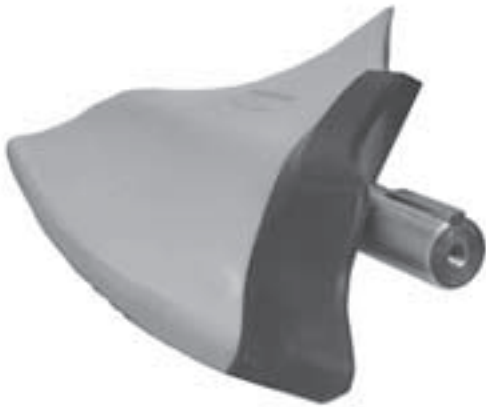

Fit the damper (a) and the key (b) on the blade shaft.



Fit the mounting tool ( art. No. 587 61 00) onto the blade shaft.



Put the blade into the hub.



When the blade is assembled remove the mounting tool.

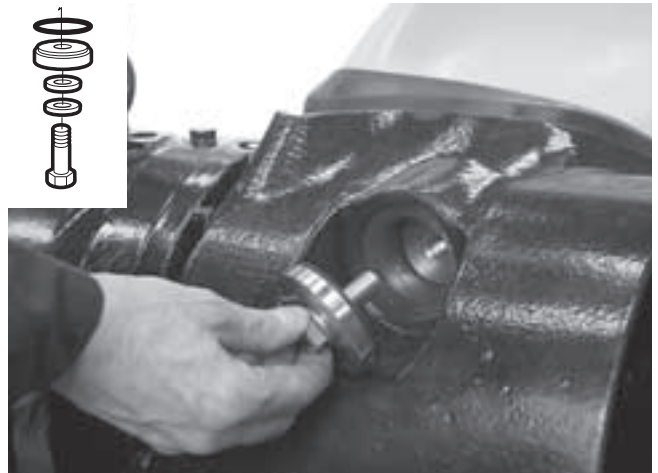

Place the two small washers, the washer and the o-ring on the screw and tighten it.



Tightening torque 150 Nm.

Do the same with the other blade.

### Reducing the diameter on the propeller blades

When the propeller blades need to be cut to size, they should first be installed in the hub.

Use a pencil and a string to find the appropriate length.

The blade tip should be rounded off with a file and the area where fibres have been cut should be painted with International 2-component polyurethane boat paint or similar. The closest International colour is No. 1002.



# Fault Tracing (Troubleshooting)



## NOTE for Ex version!

**All work on the explosion-proof motor section must be performed by personnel authorized by Flygt.**

A universal instrument (VOM), a test lamp (continuity tester) and a wiring diagram are required in order to carry out fault tracing on the electrical equipment.

Fault tracing should be done with the power supply disconnected and locked off, except for those checks which cannot be performed without voltage.

Always make sure that there is no one near the mixer when the power supply is turned on.

Use the following checklist as an aid to fault tracing. It is assumed that the mixer and installation have formerly functioned satisfactorily.

Electrical work should be performed by an authorized electrician.

Follow local safety regulations and observe recommended safety precautions.

## 1. The mixer fails to start

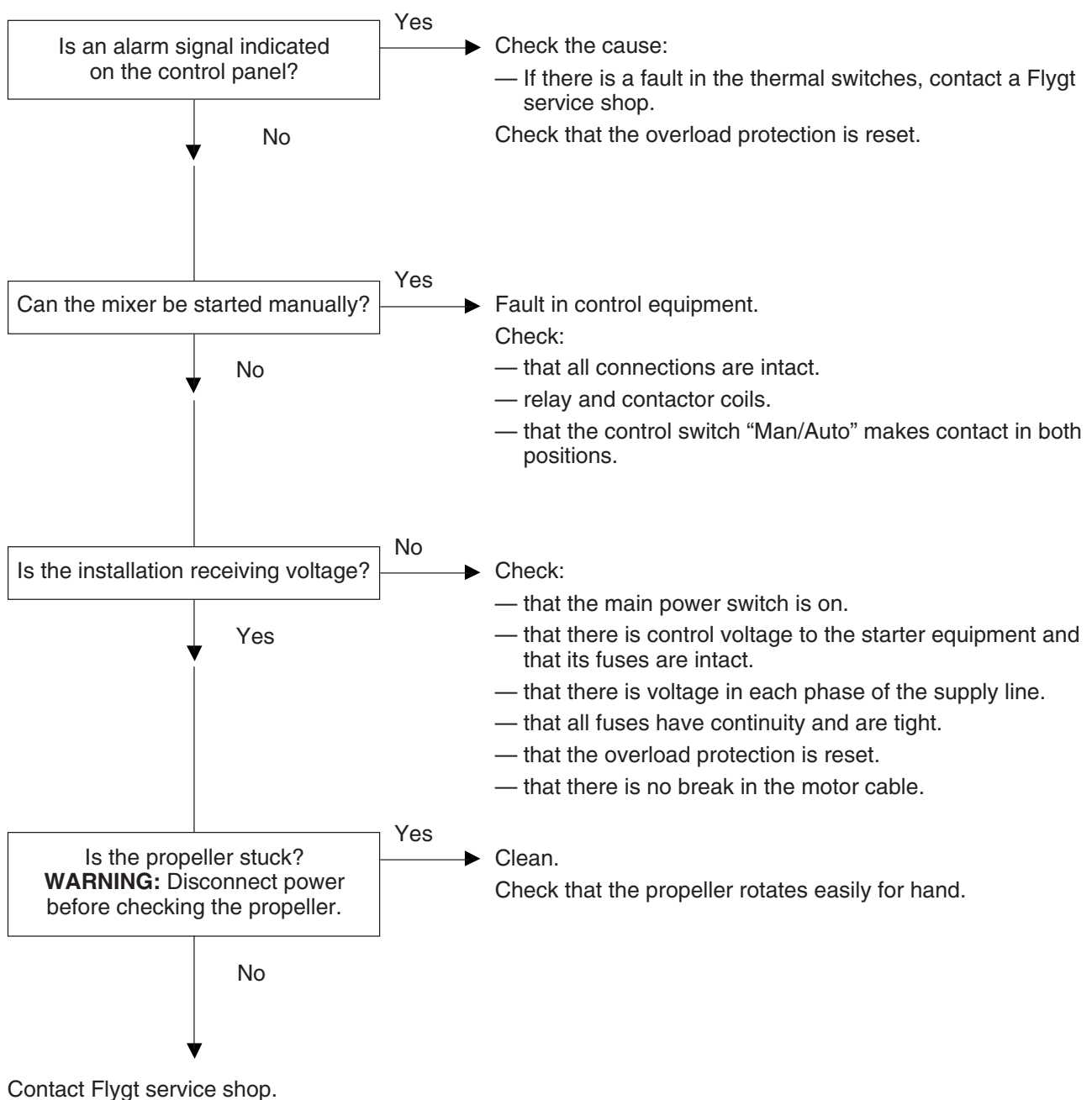

## 2. The mixer starts but motor protection trips

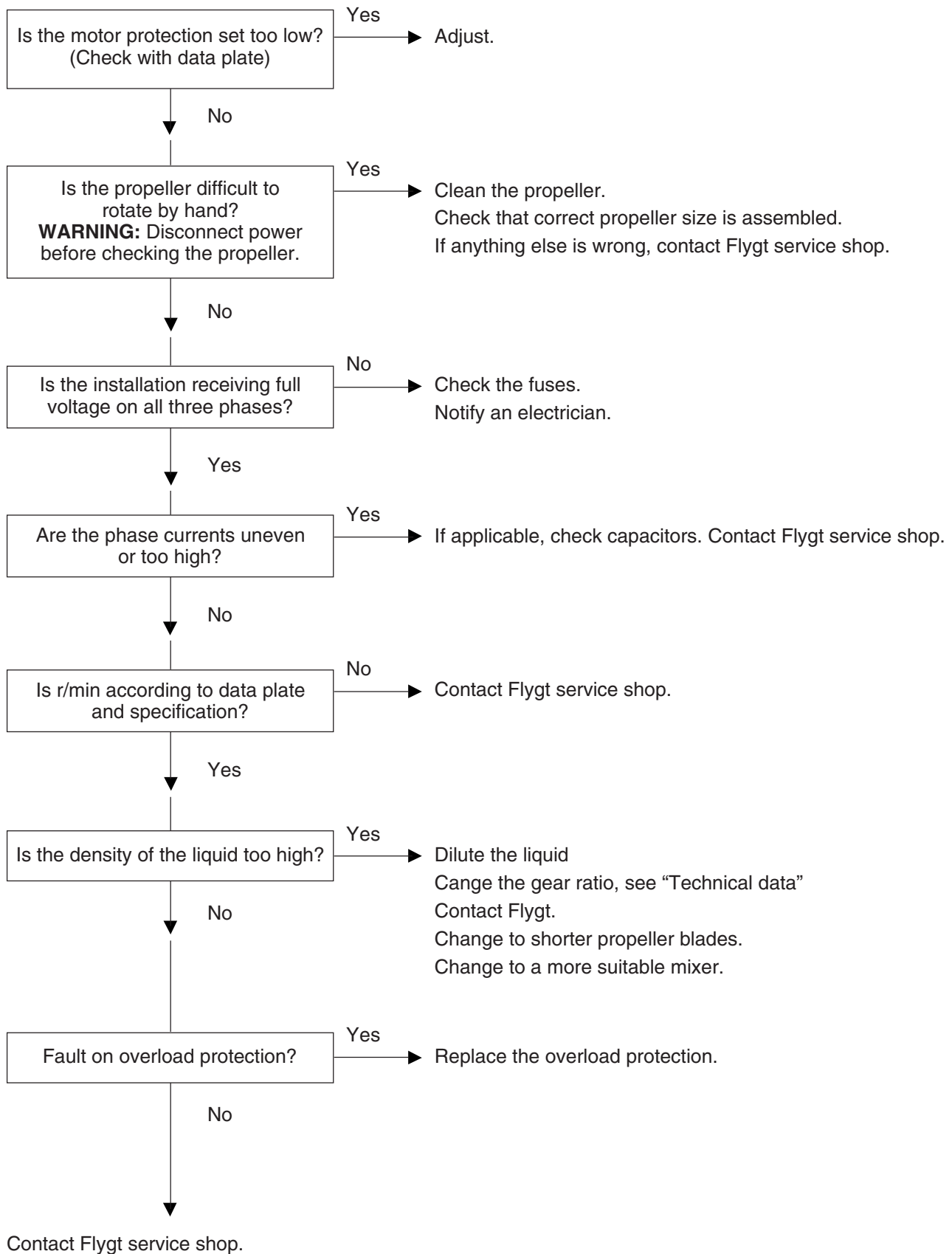

### 3. The mixer starts-stops-starts in rapid sequence

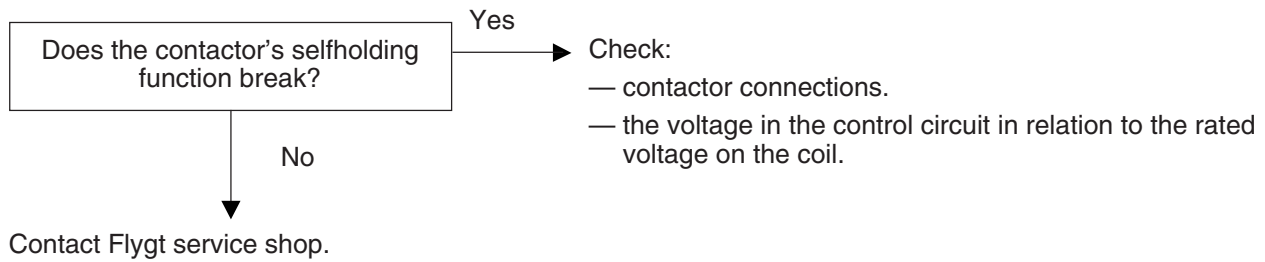

**Do not override the motor protection repeatedly if it has tripped.**

## ACCESSORIES AND TOOLS

### Zinc anode set

In order to reduce corrosion on the mixer, it can be fitted with zinc anodes.

Order No.: See "Parts list".

### Start and control equipment

Flygt has suitable starting and control equipment for the mixer. Contact Flygt for further information.

### Tools

Besides standard tools, the following tools are required in order to perform the necessary care and maintenance of the mixer:

Part No.	Description
84 15 66	Torque wrench 0–137 Nm (0–101 ft lb)
84 15 64	Torque wrench 50–225 Nm (37–166 ft lb)
84 20 49	Puller
84 14 45	Jaw
580 85 00	Assembly tool for workshops, propeller blade
587 61 00	Assembly tool, propeller blade

For further information on tools, see Flygt's Tool Catalog.



[www.flygt.com](http://www.flygt.com)