



Installation, Care and Maintenance

C3300/6x5, C/R3231, C3306, C3312, C3351, C3356, C3400, C3501, C3531, C3602, C3800



CONTENTS

Safety _____	2	Electrical connections _____	13
Guarantee _____	3	Connection of auxiliary cable _____	13
Data plate interpretation _____	3	Connection of motor leads _____	15
Transportation and storage _____	5	Care and maintenance _____	18
Installation and start-up _____	6	Service/Inspection _____	18
Safety precautions _____	6	Safety precautions _____	19
Handling equipment _____	6	Service instructions _____	21
Installation _____	8		

SAFETY

This manual contains basic information on the installation, operating and maintenance and should be followed carefully. It is essential that these instructions are carefully read before installation or commissioning by both the installation crew as well as those responsible for operation or maintenance. The operating instructions should always be readily available at the location of the unit.

Identification of safety and warning symbols



General Danger:

Non-observance given to safety instructions in this manual, which could cause danger to life have been specifically highlighted with this general danger symbol.



High Voltage:

The presence of a dangerous voltage is identified with this safety symbol.

WARNING!

Non-observance to this warning could damage the unit or affect its function

Qualifications of personnel

An authorized (certified) electrician and mechanic shall carry out all work.

Safety regulations for the owner/operator

All government regulations, local health and safety codes shall be complied with.

All dangers due to electricity must be avoided (for details consult the regulations of your local electricity supply company).

Unilateral modification and spare parts manufacturing.

Modifications or changes to the unit/installation should only be carried out after consulting with ITT Flygt.

Original spare parts and accessories authorized by the manufacturer are essential for compliance. The use of other parts can invalidate any claims for warranty or compensation.

Dismantling and re-assembly

If the pump has been used to pump hazardous media, care must be taken that, when draining the leakage, personnel and environment are not endangered.

All waste and emissions such as used coolant must be appropriately disposed of. Coolant spills must be cleaned up and emissions to the environment must be reported.

The pumping station must be kept tidy and in good order at all times.

All government regulations shall be observed.

GUARANTEE

Flygt undertakes to remedy faults in products sold by Flygt provided:

- that the fault is due to defects in design, materials or workmanship;
- that the fault is reported to Flygt or Flygt's representative during the guarantee period;
- that the product is used only under conditions described in the care and maintenance instructions and in applications for which it is intended;
- that the monitoring equipment incorporated in the product is used and correctly connected;
- that installation and start-up is done by Flygt authorized personell;
- that all service and repair work is done by a workshop authorized by Flygt;
- that genuine Flygt parts are used.

Hence, the guarantee does not cover faults caused by deficient maintenance, improper installation, incorrectly executed repair work or normal wear and tear.

Flygt assumes no liability for either bodily injuries, material damages or economic losses beyond what is stated above.

Flygt guarantees that a spare parts stock will be kept for 20 years after the manufacture of this product has been discontinued.

The manufacturer reserves the right to alter performance, specification or design without notice.

DATA PLATES INTERPRETATION

DRIVE UNIT

- A Serial number
- B Product code + Number
- C Motor denomination
- D Country of origin
- E Product number
- F Additional information
- G Phase; Type of current; Frequency
- H Rated voltage
- I Thermal protection
- J Thermal class
- K Rated shaft power
- L International standard
- M Degree of protection
- N Rated current
- O Rated speed
- P Max. submergence
- R Duty class
- S Duty factor
- T Product weight
- U Locked rotor code letter
- V Power factor
- X Max. ambient temperature

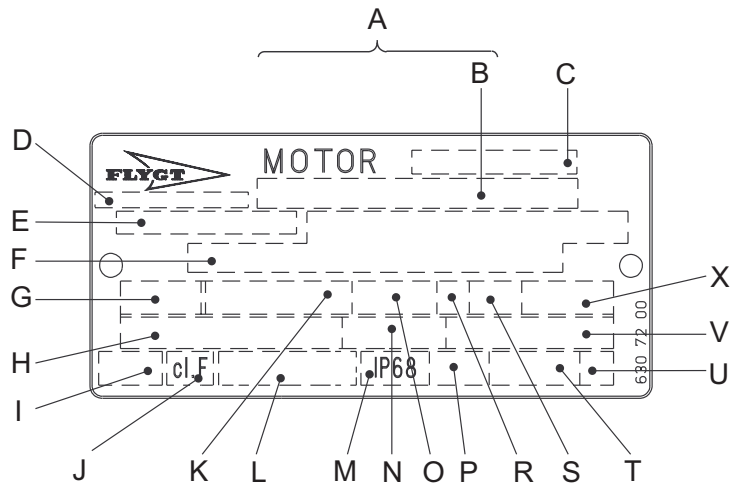

DATA PLATES INTERPRETATION

HYDRAULIC UNIT

- A Serial number
- B Product code + Number
- C Country of origin
- D Product number
- E Column dia./Inlet & outlet dia.
- F Pressure class
- G Rated speed
- H Impeller/Propeller code
- I Direction of rotation: L=left, R=right
- J Product weight
- K Propeller blade angle
- L Impeller diameter

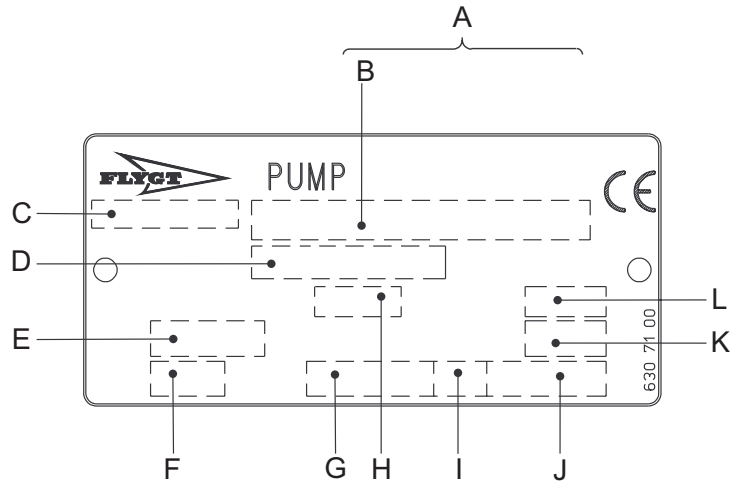

APPROVAL PLATES

These approval plates apply to an explosion-proof submersible Flygt pump. The plates are used together with the general data plate on the pump.

- EN:** European Norm
ATEX Directive
EN 50014, EN 50018, EN 1127-1

- II 2 G EEx dII T4/T3 (6x5)
- II 2 G EEx dII T4(20°C)/T3 (7x5)
- II 2 G EEx dII T3 (8x5)
- II 2 G EEx dII T4(25°C)/T3 (9x5)

- A Approval
- B Approval authority + Approval Number
- C Approval for Class I
- D Approved drive unit
- E Stall time
- F Starting current / Rated current
- G Duty class
- H Duty factor
- I Input power
- J Rated speed
- K Controller
- L Additional information
- M Max. ambient temperature
- N Serial number
- O ATEX Marking

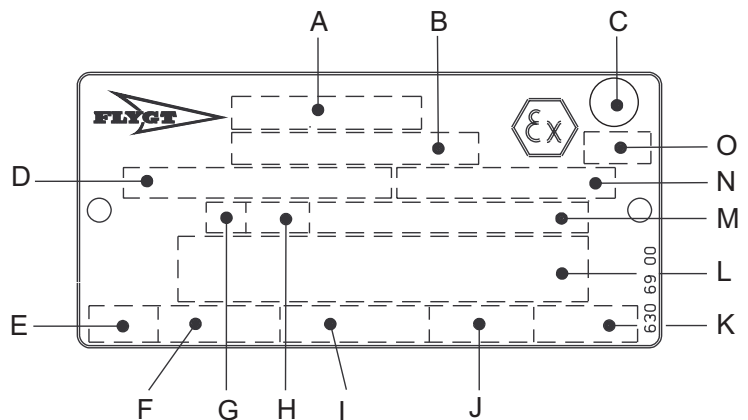

- FM:** Factory Mutual

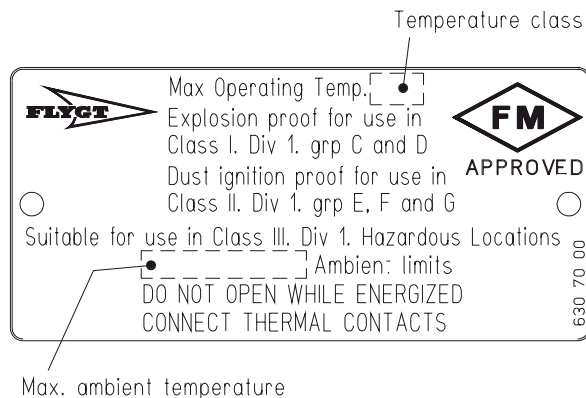

TRANSPORTATION AND STORAGE

The pump may be transported and stored in a vertical or horizontal position. Make sure that it is securely fastened and cannot roll or fall over.

The impeller shall be locked during transport.



Warning!

Always lift the pump by its lifting link and/or by the appropriate lifting eye brackets (service tools), never by the motor cable or other parts. Make sure that it cannot roll or fall over.

Remove the impeller locking device before installing the pump. Pumps with drive units 605, 665 are delivered in vertical position and are not equipped with the impeller locking device.

During storage, the pump must be protected against moisture and heat. The impeller should be rotated by hand every other month to prevent the seals from sticking together. If the pump is stored for more than 6 months, this rotation is mandatory. For this operation the impeller locking device has to be removed and reinstalled. Reinstall the locking device in vertical position as shown in the picture. Clamp the locking device into position by turning and locking it by hand as tightly as possible. After hand-tightening the unit, turn, depending on the size of the hydraulic unit, a further 1/8 — 1/3 of a turn to approximately the torque specified in the cross sectional drawing. Please see each respective parts list. (Not valid for pumps with drive units 605 and 665).

Pumps delivered in vertical position

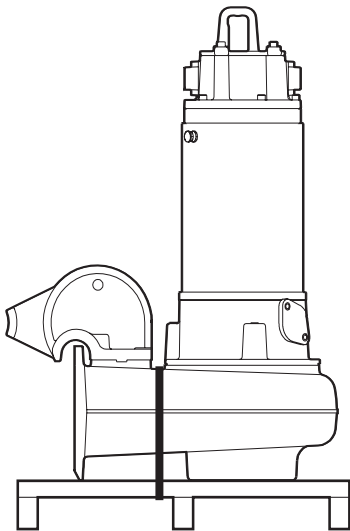

The pump is frostproof as long as it is operating or is submersed in the liquid. If the pump is taken up when the temperature is below freezing, the impeller and the cooling jacket may freeze.

When CP-, CS- and RP-pumps, with integrated cooling systems, are lifted out of the sump for service or storage, the cooling jacket must be drained manually by opening the air vent screw(s) at the top of the cooling jacket. See picture in page 10, "Cooling system".

The pump should also be run for a short period of max. 30 seconds to expel all water from the impeller area.

NOTE!

The pump may not run dry longer than 30 seconds.

If the pump is to be stored at temperatures at or below the freezing point, these procedures are mandatory.

A frozen impeller can be thawed by allowing the pump to stand immersed in the liquid for a short period before it is started. Never use a naked flame to thaw the pump.

If the pump is kept where there is a risk of freezing temperatures it is liable to be damaged if there is water left in the hydraulic unit.

In order to avoid this, cover the discharge opening in a suitable way.

Pumps delivered in horizontal position

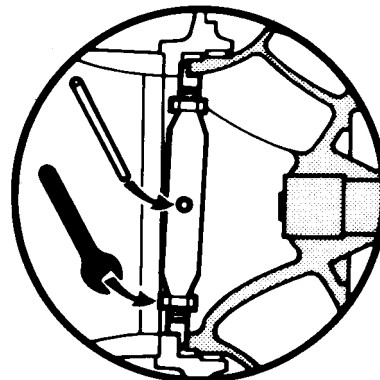
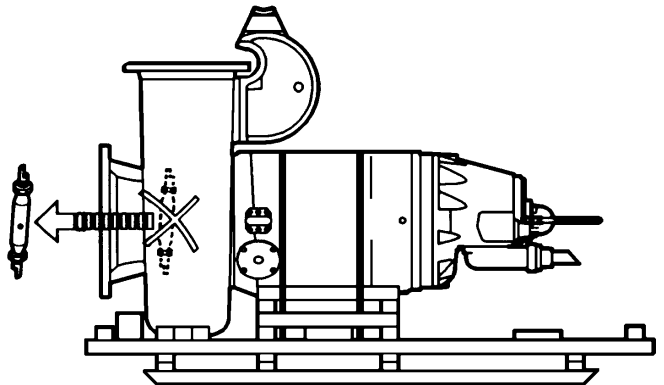

INSTALLATION AND START-UP

Safety precautions



Follow all health and safety rules and local codes and ordinances.

For extra safety and in order to minimize the risk of accidents in connection with the service and installation work, the following rules should also be followed:

1. Make sure there are no poisonous gases within the work area.
2. Check the explosion risk before welding or using electric hand tools.
3. Bear in mind the risk of electrical accidents.
4. Make sure that the lifting equipment is approved and in good condition.



Warning!
If the pump is installed in such a way that it can be exposed to temperatures at or below the freezing point (i.e. not totally submerged) special modifications must be made to the pump and the installation.
Please contact your Flygt representative for information.

Handling equipment

Lifting equipment is required for handling the pump.

The lifting equipment shall be able to hoist the pump straight up and down in the sump, preferably without necessitating resetting the lifting hook.

The minimum height between the lifting hook and the access frame/cover/floor is individual for every installation. For further information, please contact your Flygt representative.

Make sure that the lifting equipment is securely anchored.

Two sets of lifting equipment are required to handle the pump for repair work.

The total weight of the pump is stated on the data plate of the hydraulic unit.

Removing the transport pallet

Pumps delivered in vertical position

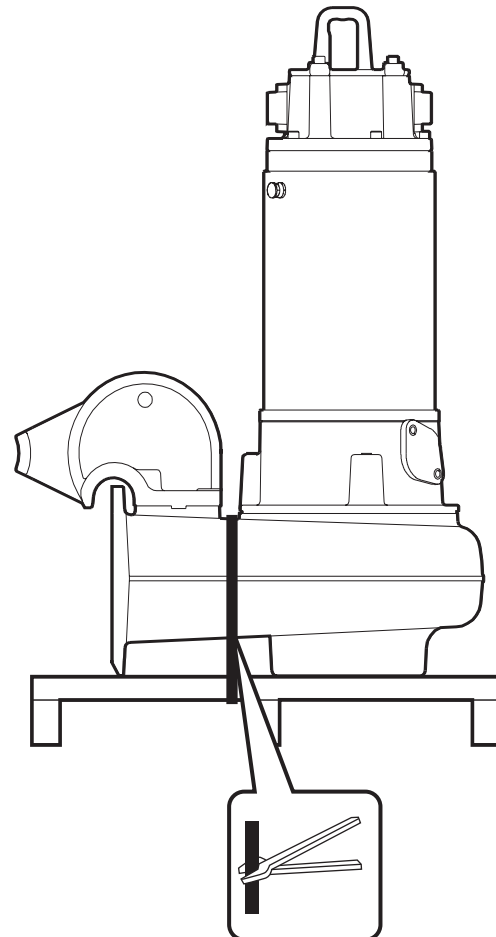

Pumps delivered in horizontal position



Note!
When handling the pump from and to horizontal position, the pump should always be lifted by the lifting link with the support plate removed.

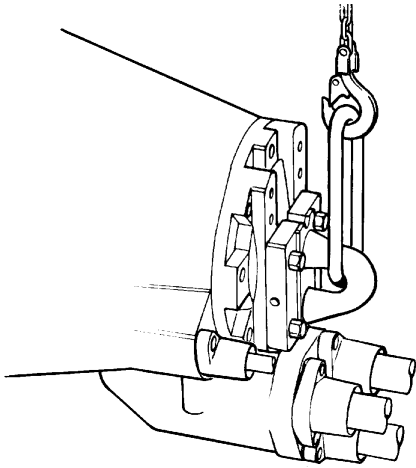
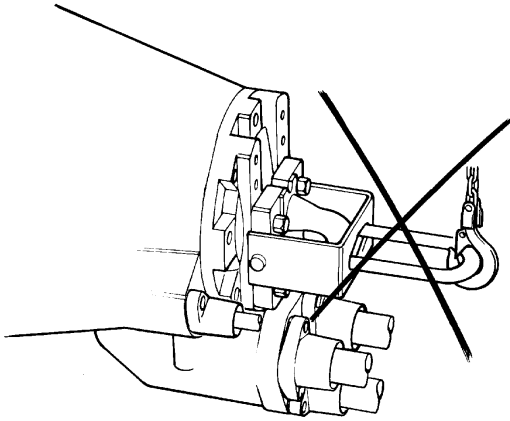

Raise the pump to its upright position while still attached to the transport pallet.

The pump will jolt and possibly sway slightly towards the end of the raising operation.



WARNING!
To avoid accidents stand at a safe distance, until this movement has been stopped.

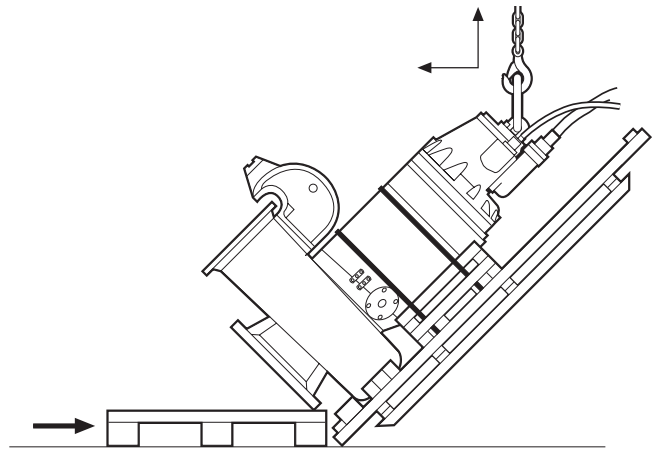

To minimize the jolt when raising the pump slide a pallet or similar object under the inlet section.



NOTE! Please make sure that the support-columns on C3231 with drive units 705-775 are outside the pallet as they may break if used as a supports when raising.

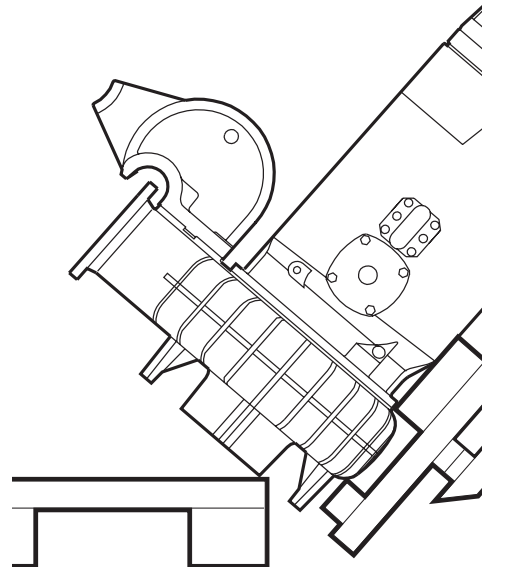

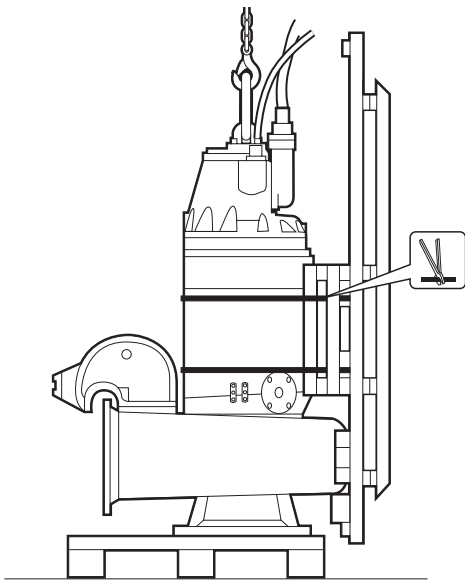

Remove the transport pallet after placing the pump in upright position.



WARNING!
Keep out from under suspended loads.

Lift up the pump and remove the support pallet.

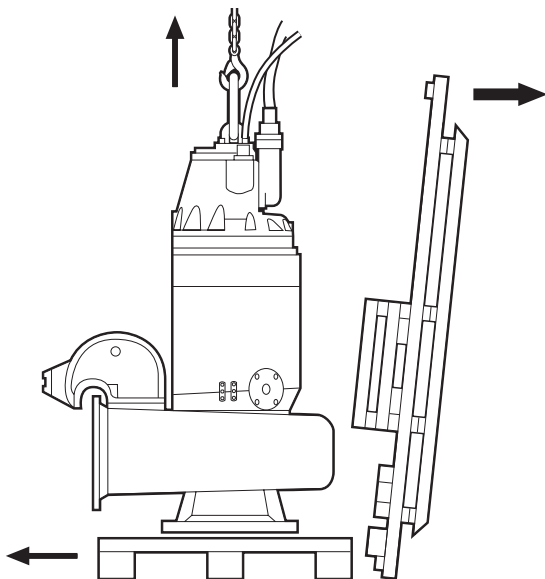

NOTE!
Place the pump on a rigid horizontal surface and make sure that the pump cannot fall.

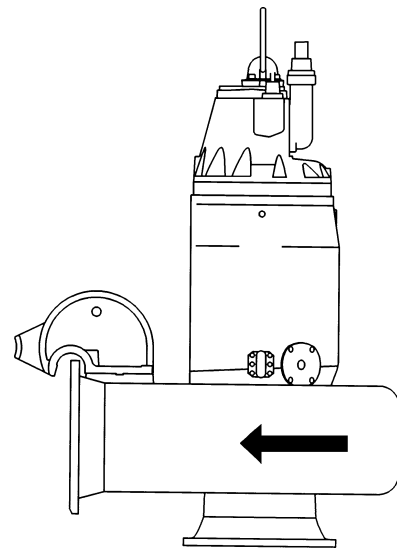

Direction of rotation

Installation

Consult your nearest Flygt representative regarding:

- sizing of sump, pumping station and access frame.
- choice of ancillary equipment.
- other aspects of installation.



Note (Sound Pressure Diagram)!
In certain installations and at certain operating points on the pump performance curve, the noise level of 70 dB can be exceeded.

Pumps with power output greater than 30kW, as shown in the diagram below, may have a noise level between 70dB and maximum 85dB at the best efficiency point.

Sound pressure

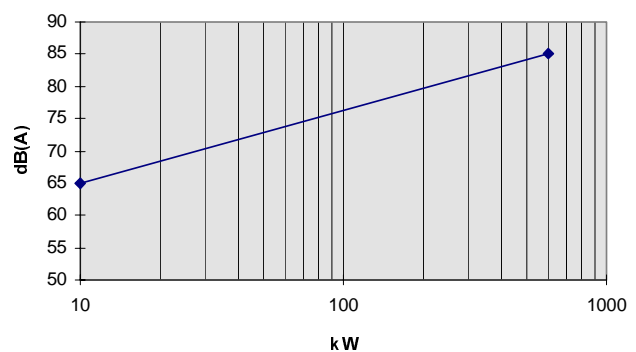

The pump should always be inspected before it is put into operation. Pay special attention to the seals and the cable entry. Rotate the impeller by hand with the pump isolated from power supply before final installation.

During a longer period out of operation, the pump shall be test-started every other month to prevent the mechanical seals from sticking together.

NOTE!

The pump may not run dry longer than 30 seconds.

Maximum permissible submersion depth is 20 m (65 ft).

Pumps with drive units 605-675

Lifting of drive unit only Complete pump

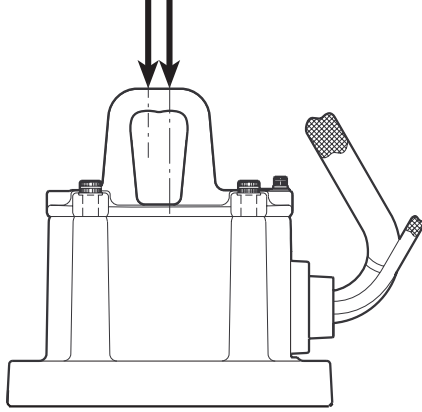

Pumps with drive units 705-775

Lifting of drive unit only
and lifting of complete pump C3231—C3356

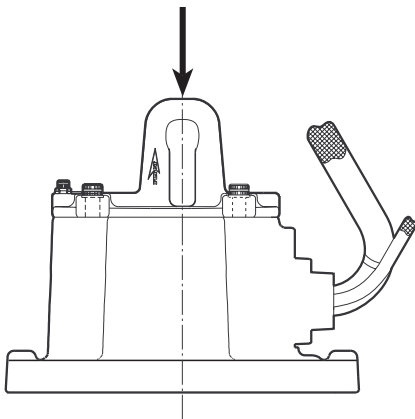

Lifting of complete pump C3400—C3602

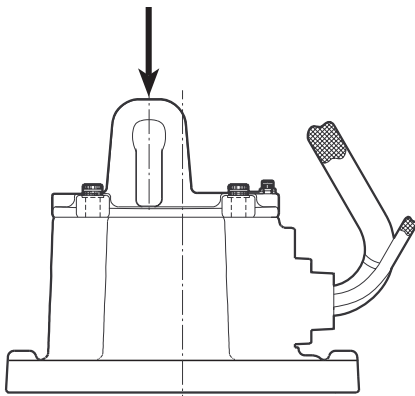

Note!
For lifting of drive unit only for C3400 — C3602 the lifting cover has to be turned 180° .

Pumps with drive units 805-975

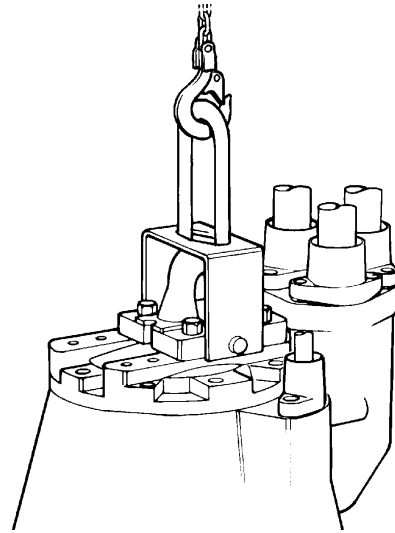

Note!
When hoisting the pump down or up in the pump station the lifting link support plate should be mounted.

Make sure that the adjustable lifting bracket assembly is positioned so that the complete pump hangs forward with an incline of 0-2° in relation to the vertical axis.



Note!
Make sure that all the screws holding the lifting bracket assembly in place are tightened to the correct torque, i.e. 472 Nm (348 ft. lb.).

Referring to table below, make sure that the cables are not sharply bent or pinched.

SUBCAB® Cable	Min. bending radius in mm
12x1,5 mm ²	85
24x1,5 mm ²	145
4 G 16 mm ²	140
4 G 25 mm ²	175
4 G 35 mm ²	195
4 G 50 mm ²	225
4 G 70 mm ²	245
4 G 95 mm ²	290
4 G 120 mm ²	300
4AWG/3-2-1-GC	175
1AWG/3-2-1-GC	215



NOTE!
The end of the cable must not be submerged. Leads have to be above flood level, as water may penetrate through the cable into the junction box.

Cooling system

The CP-version is delivered as standard without cooling jacket. This pump should always run completely submerged. At emptying the sump the lowest liquid level should not be lower than to the top of the pump housing. Please contact your Flygt representative for further information.

The heat losses in the motor are removed by means of a water filled cooling jacket.

The pump is delivered with the cooling jacket adapted to either of the following two cooling system types:

I. Integrated cooling

A small amount of the pumped media is used to cool the motor. Circulation through the cooling jacket is obtained by means of vanes on the upper part of the impeller.

II. External cooling (three versions)

a. External cooling only

Coolant from an external source is used to cool the motor. There are two threaded connections (ISO G 3/4) on the cooling jacket, the one in lower part for coolant inlet and the one in the upper part for coolant outlet.

b. External cooling and integrated seal flushing

c. External cooling and separate seal flushing

For more information regarding the a-, b- and c-versions please contact your Flygt representative.

Draining the cooling jacket

Drainage of the cooling jacket for all installations can only be accomplished if the air vent screws "A" at the top of the cooling jacket are opened.

After draining the cooling jacket on CP-, RP- and CS- installed pumps with integrated cooling and external cooling, the pump should be run dry for a short period of max 30 seconds to expel all water from the impeller area.

NOTE!

The pump may not run dry longer than 30 seconds.

The cooling jacket used on CT, CZ and RT pumps with integrated cooling, or on CP-, RP-, CS-, CT- and RT- installed pumps with external cooling, should, when the pump is installed, be fitted with a nipple, a stop-cock and a pipe or a hose leading to a suitable sump.

See pictures below.

The cooling jacket contains water which may be pressurized. Make sure therefore that the cooling jacket is drained before service work is started.

First depressurize the cooling system by opening the stop-cock, then drain the cooling jacket.

CT-, CZ- and RT-pumps with integrated cooling

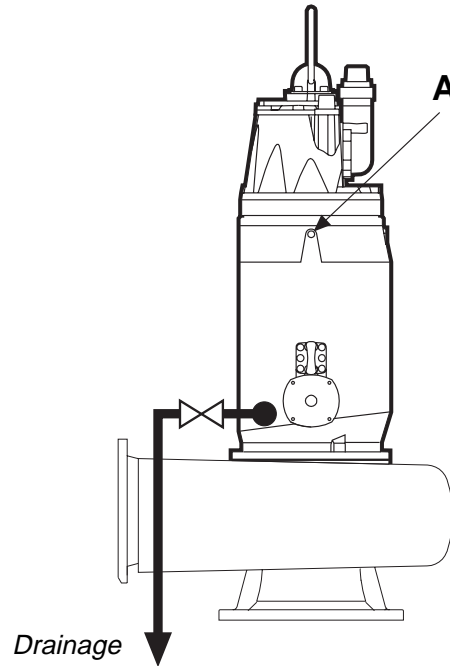

CP-, RP-, CS-, CT- and RT-pumps with external cooling

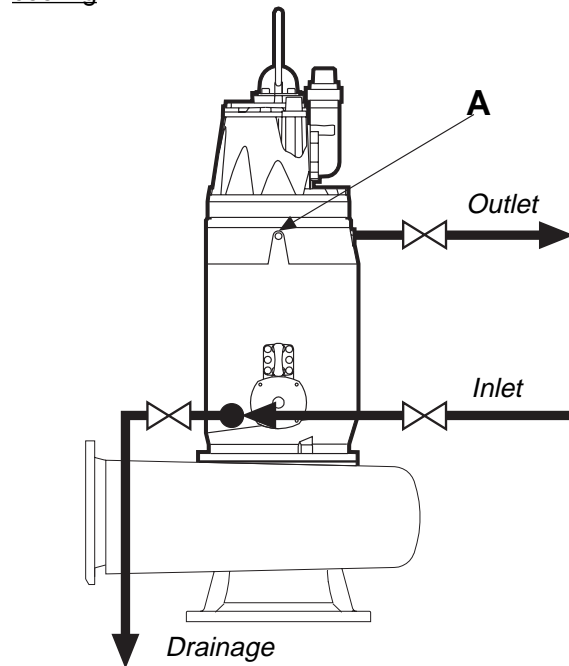

WARNING!

Failure to drain the cooling jacket before service may cause injury.



NOTE!

Before starting service on the pump, make sure that the motor has cooled down sufficiently to carry out the service work.

CP version

In the CP version, the pump is installed on a stationary discharge connection and operates completely or partially submerged in the pumped liquid.

In addition to the pump, the following items are required:

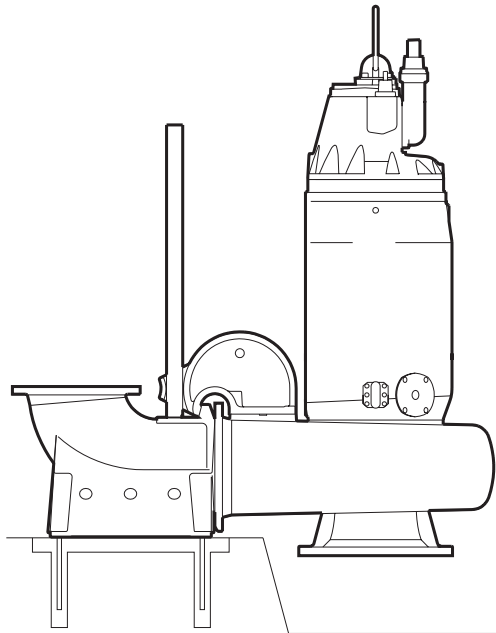

Guide bars

Guide bracket for attaching the guide bars to the access frame or to the upper part of the sump.

Level sensors or other control equipment for start, stop and alarm.

Cable holder for holding the cable and regulating the height of the level sensors.

Access frame (with covers) to which the upper guide bar bracket and cable holder can be attached.

Discharge connection for connecting the pump to the discharge line. The discharge connection has a flange which fits the pump casing flange and two bosses for attaching the guide bars.

Bushings for vibration damping between the guide bars and the discharge connection.

Discharge connection with anchor bolts and beams for anchoring the discharge connection.

CP installation

In the finished station:

- Provide a barrier around the pump pit, for example a guard rail.
- Arrange for a cable between the sump and the electric control box.
- Check that the guide bars are vertically.
- Lower the pump along the guide bars.
- Fasten the lifting chain on the access frame and the cables on the cable holder. Make sure that the cables cannot be sucked into the inlet of the pump. Support straps are required for deep installations.
- Run the cables up to the electric control box.

On reaching its bottom position, the pump will automatically connect to the discharge connection.

The pump can be hoisted up along the guide bars for inspection without any connections having to be undone.

CS version

(only valid for C3300/6x5, C3231, C3306 and C3312)

In the CS version, the pump is transportable and intended to operate completely or partially submerged in the pumped liquid. The pump is equipped with a connection for hose, see "Parts list".

The pump is bolted to a base stand.

CS installation

Run the cables so that they have no sharp bends, are not pinched and cannot be sucked into the pump inlet. Connect the discharge line and the motor cable. See "Electrical connections".

Lower the pump into the sump.

Place the pump on a base which prevents it from sinking into a soft sump bottom. Make sure it cannot fall over.

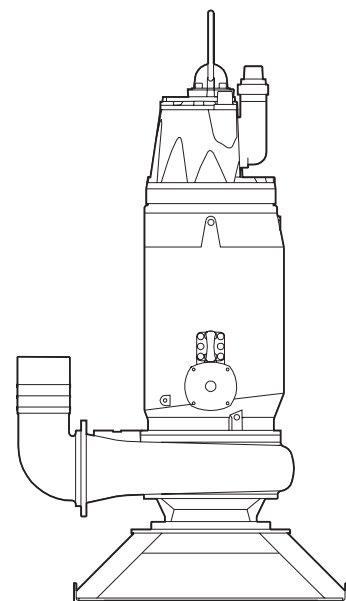

CT/CZ version

In the CT version, the pump is installed in a stationary position in a dry well next to the wet sump.

In the CZ version, the pump is installed horizontally in a stationary position in a dry well next to the wet sump.

The pump has a watertight motor and will therefore not be damaged in the event of flooding in the pump room.

The pump housing on CT/CZ-installed pumps is equipped with an inspection cover.



WARNING!

This cover must never be removed during service or internal cleaning of the pump housing until the pump has been de-energized and drained.

For this purpose the suction pipe shall be equipped with a drainage connection.

In addition to the pump, the following items are required:

Plate or Base stand with anchor bolts for anchoring the pump to a concrete base.

Inlet elbow for connecting the suction line.

Shut-off valves to permit the pump to be removed for repair.

Air vent on discharge side between the pump and the check valve.

Level sensors or other control equipment for start, stop and alarm.

CT/CZ installation

The pump should be positioned low in the dry pit for effective drainage.

Bolt the base stand or plate to the concrete base by means of grouted-in anchor bolts.

Bolt the pump to the stand/plate.

Check that the pump is vertical/horizontal.

Connect the motor cable, suction line and discharge line.

Make sure that the weight of the pump does not bear on the system piping.



NOTE!

The risk of freezing is particularly great at certain CT/CZ-installations.

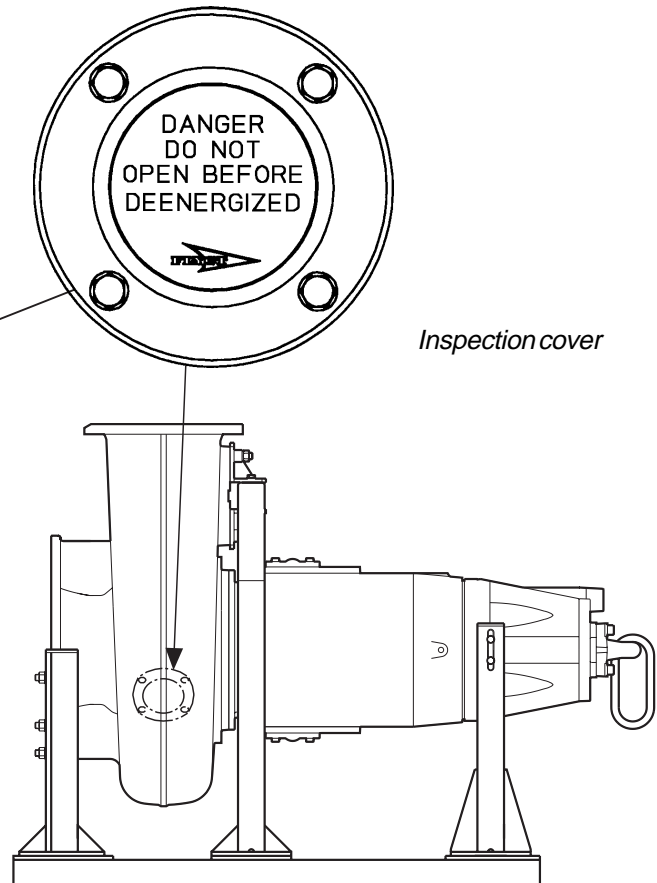
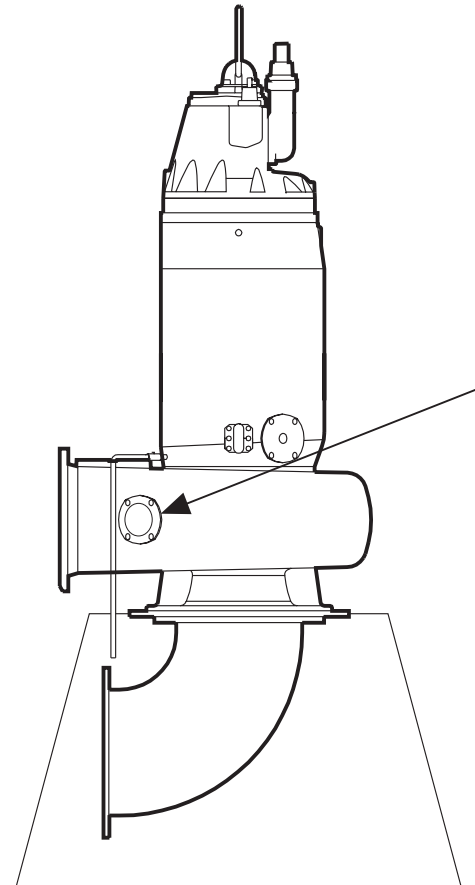

ELECTRICAL CONNECTIONS

All electrical work shall be carried out under the supervision of an authorized electrician.

Local codes and regulations shall be complied with.



WARNING!

All main electrical equipment must be earthed. Failure to heed this warning may cause a lethal accident. Make sure that the earth lead is correctly connected by testing it.

Under no circumstances may the starter equipment be installed in the pump pit.

Connection of auxiliary cable

The pump is delivered with the auxiliary cable mounted.

Depending on which monitoring equipment the pump is equipped with, there are two types of auxiliary cable (SUBCAB®) available:

- 12 x 1,5 mm² (conductors numbered 1-12)
- 24 x 1,5 mm² (conductors numbered 1-24)

The number of conductors required to connect the sensors to the monitoring system is dependent on the number as well as the type of sensors being used.

Three alternative versions are used:

- I Standard version (Thermal switches or thermistors in stator) and one or more additional sensors with exception of Pt 100 in stator.
- II Standard version (Thermal switches and three Pt 100 in stator).
- III Standard version acc. to II and one or more additional sensors.

The different sensors (as applicable) are connected to the conductors as shown in the table below:

Sensors	Conn. No.	Conductor No.		
		I (12-lead)	II (12-lead)	III (24-lead)
Float switch in the stator housing	1	1	1	1
	2	2	2	2
Pt 100 in the main bearing arrangem.	3	3	3	3
	4	4	4	4
Thermal switches or thermistors in the stator	5	5	5	5
	6	6	6	6
Pt 100 in the support bearing *)	37	7	—	7
	38	8	—	8
Float switch in the junction box	9	9	—	9
	10	10	—	10
CLS 30 water in oil housing	33	11	—	11
	34	12	—	12
Pt 100 in the stator	19		7	19
	20		8	20
	21		9	21
	22		10	22
	23		11	23
	24		12	24

*) Not available for the 605-series drive units.

Note! Important

As the cable ends are sealed to eliminate moisture entrainment during transport and storage, the wire markings for the sensors at the outlet end of the cable will not be carried out at the factory. Marking must therefore be carried out during installation of the pump.

Connection of monitoring equipment

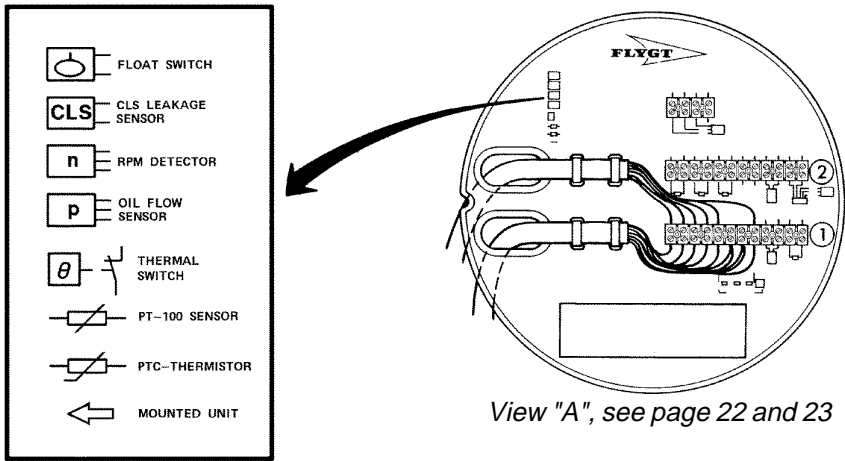

Alternative

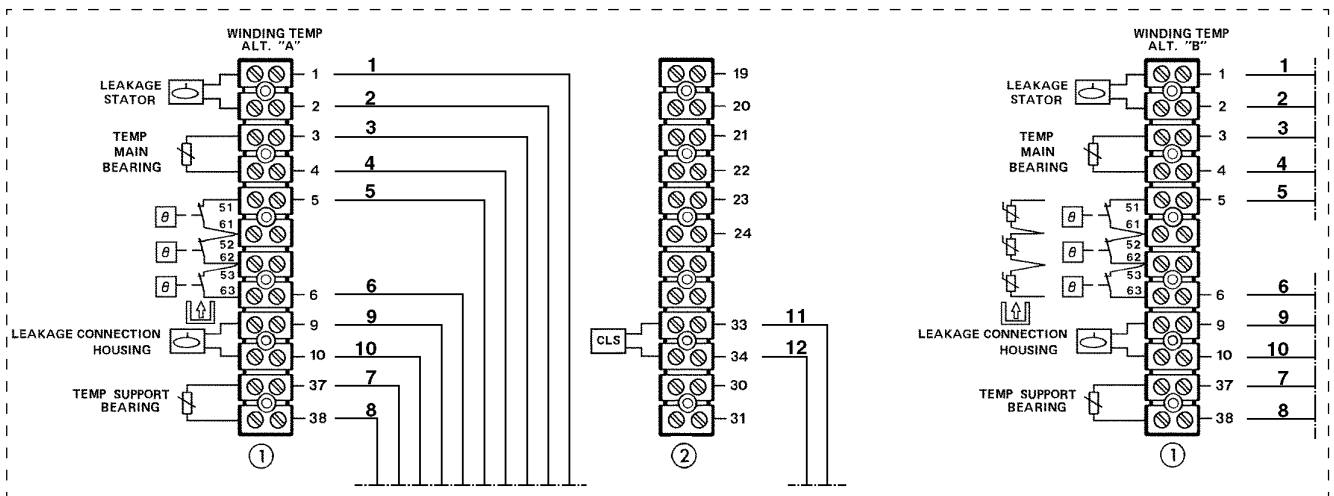

Alternative II

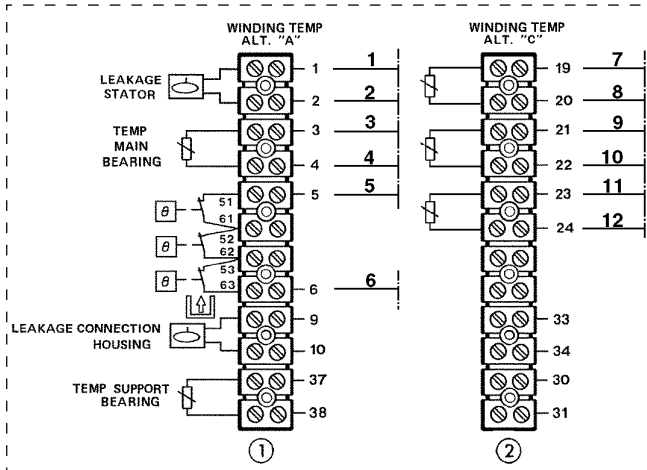

Alternative III

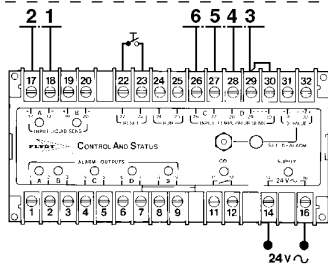
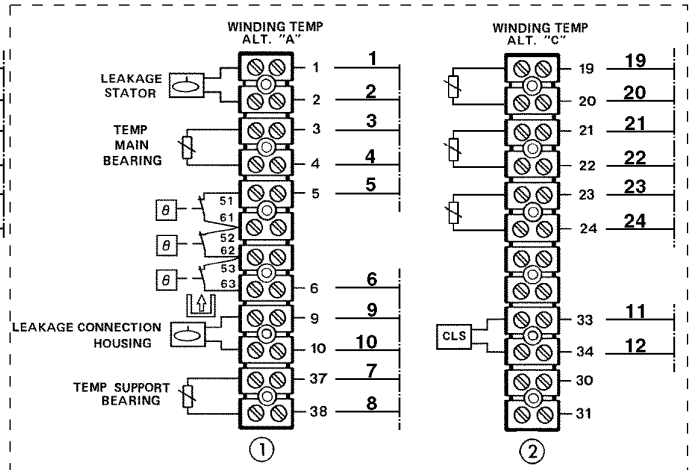

Connection of motor leads

The pump is delivered with the power cable(s) mounted.

Check that the mains voltage and frequency agree with the specifications on the pump data plate.

Depending on which drive unit the pump is equipped with, there are different types of cable entrance arrangements. All types consist of seal sleeves and washers mounted around the cable and into an entrance flange.

Install the power cable and the auxiliary cable where necessary as illustrated in the figure.

To avoid leakage into the pump, check:

- that the cable entry seal sleeves and washers conform to the outside diameter of the cable. See the parts list. Always measure the cable before installing it.
- that the outer jacket on the cable is not damaged. When refitting a cable which has been used before, always peel off a short piece of the cable so that the cable entry seal sleeves does not close around the cable at the same points again.
- that the cable sheathing does not have indentations or is embossed (with markings etc.) at the cable entry.
- that the minimum bending radiuses for the cables do not underpass the values acc. to the table in page 9.

Drive units 605-775

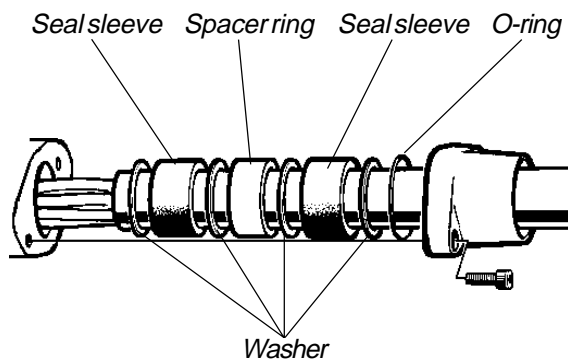

Drive units 805-975

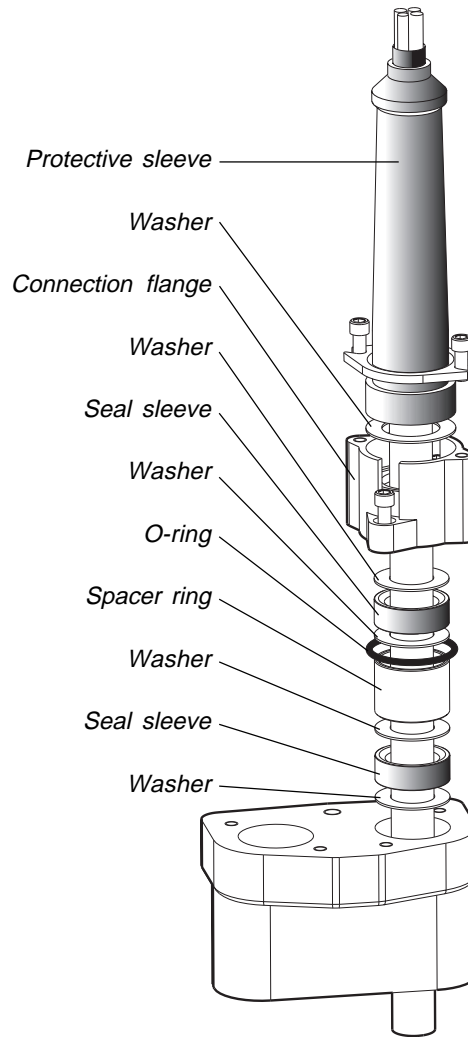

The entrance flange for these drive units is designed to avoid excessive bending of the cable. A sturdy rubber protective sleeve is mounted onto the cable where it leaves the cable entry. The protective sleeve is supported by a washer at its lower end and clamped down in place by a connection flange, which is fastened to the top of the entrance flange with two screws.

The sealing function involves three different components, i.e. the cable, the seal sleeve and the entrance flange itself. The size of the seal sleeves must be chosen correctly to give correct compression around the cable, which in turn must be sufficiently geometrically stable over time, i.e. the compression set should be negligible. The cable entry flange must also give the cable a proper support so that the cable is not excessively bent and damaged or misaligned within the seal sleeves. The seal sleeves shall be chosen to fit the actual cable diameter. Always measure the cable before installing it. Each seal sleeve is marked with its diameter range at one of its ends. See also the parts list for combining the seal sleeve and the washers.



NOTE!

For safety reasons, the earth lead should be connected in such a way that if the power cable is jerked loose by mistake, the earth lead should be the last lead to come loose from its terminal. This applies to both ends of the cable.

Check on the data plate which connection, Y or D, is valid for the voltage supply. Then, depending on voltage, arrange the connection on the terminal board in accordance with Y or D, see figure.

Connect the power cable to the terminal board connections U1, U2, V1, V2, W1, W2 and earth according to the "Terminal board connection".

Terminal board connection

Drive units 605 - 775

D-connection, 1 or 2 cables, 6-lead stator

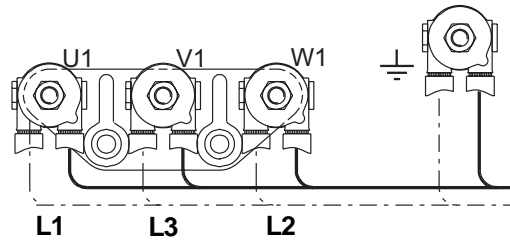

D-connection, 1 or 2 cables

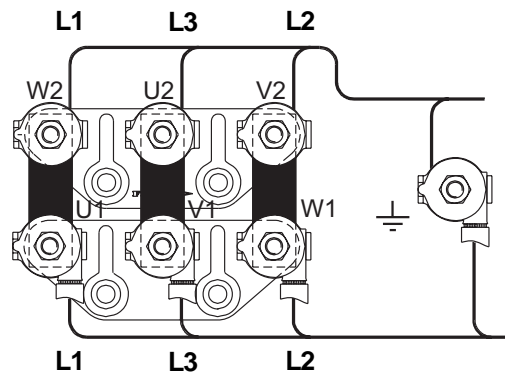

Y-connection, 1 or 2 cables

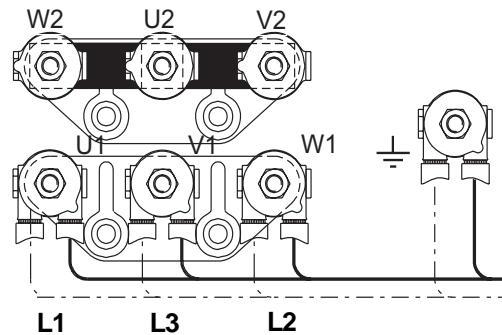

Y/D-connection

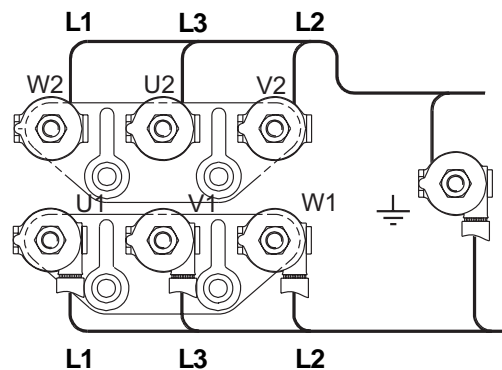

D-connection, 1 or 2 cables

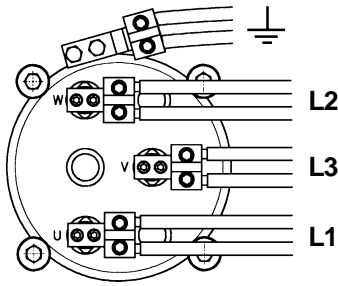

D-connection, 2 or 3 cables

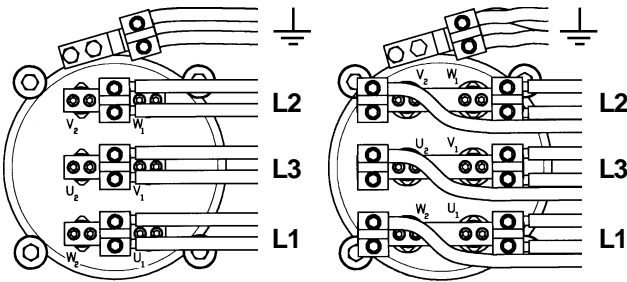

Y-connection, 1 or 2 cables

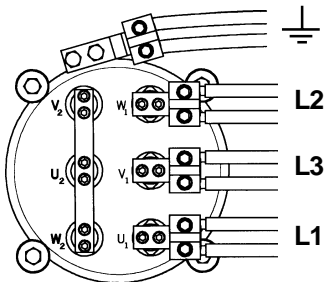

Y/D-connection

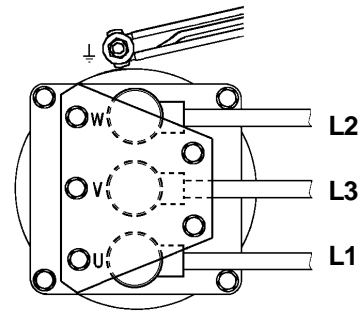
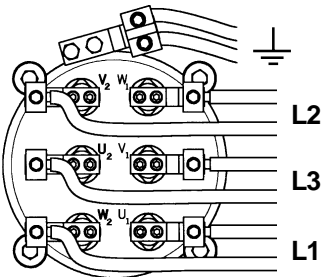

Note!
All high voltage leads are black.

Starter equipment connection

Make sure that the pump is correctly earthed (grounded).

Remember that the starting surge with the direct-on line start can be several times higher than the rated current. Make sure that the fuses or circuit breakers are of the proper amperage.

The overload protection (motor protection breaker) shall, for direct-on-line start be set to the motor's rated current as given on the data plate.

Check the phase sequence in the mains with a phase sequence indicator.

Connect the motor cable and the auxiliary cable to the starter equipment. Check the direction of rotation, see "Installation and start-up".

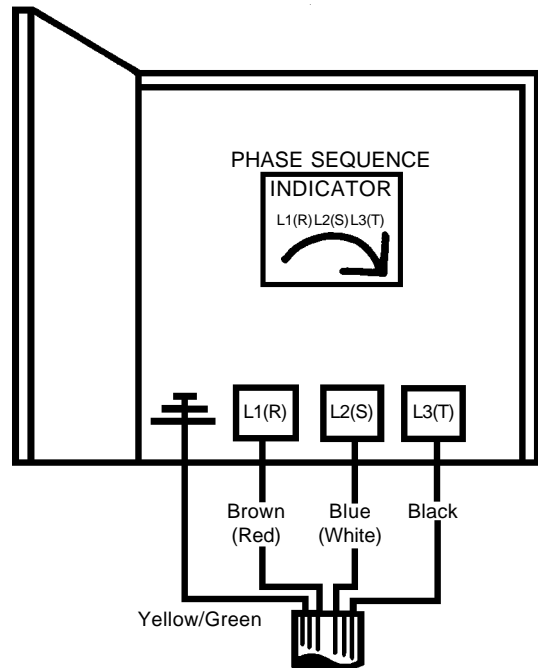

Note!
Colour marking not valid for high voltage leads.

CARE AND MAINTENANCE

Service/Inspection

ITT Flygt recommends a preventive maintenance program based on Intermediate and Major Services at regular intervals. For pumping applications where the temperature of the pumped liquid is 40°C or less an *Intermediate Service* should be performed every 5000 hours or once a year, whichever occurs first. A *Major Service* should be performed after 25000 working hours or every 5 years.

It should be observed, however, that these are general recommendations based on experience from the most

Standard Intermediate and Major Services includes the following items:

Pump	Intermediate Service 5 000 working hours/Once a year
Junction box	Check that it is clean and dry. If wet, check cable entry. Replace O-rings. Fitting of new O-rings should be made to all O-ring seals joints opened during the inspection.
Terminal board	Check that the electrical connections are properly tightened.
Isolation check	Check that the resistance between earth and phase lead is more than 5 M Ω .
Cable	Check that the rubber sheathing (jacket) is undamaged.
Oil housing	Check the oil quality. - If there is water in the oil, drain the oil and replace with new. After one week of operation check the oil quality again. If again there is water in the oil, change the seals. - If the oil is free from water, fill to correct oil level if necessary. Replace the filling plug O-rings.
Stator housing	Check that it is clean and dry. - If there is oil in the stator housing, drain and clean. After one week of operation check again. If again there is oil in the stator housing, change seals. - If there is water in the stator housing and there was water in the oil, change seals immediately. - If there is water in the stator housing but there was no water in the oil, check all other connections. Replace the O-rings.

frequent applications for these pumps. For specific applications or operating conditions other service intervals may be recommended. For example a storm water pump that works mainly during a part of the year an Intermediate Service should be performed before and after this main working period.

Service contract

Flygt or its agent offers service agreements in accordance with a preventive maintenance plan. For further information, please contact your Flygt representative.

Sensors	Check stator temperature, bearing temperature and FLS sensors. For details, see "Service instructions"
Impeller/Propeller	Check general impeller/propeller and wear ring status. Change if necessary.
Zinc anodes	Check and change if necessary.
Screw joints	Check all externally accessible screw joints and tighten if necessary to correct torque. See torque table and parts list.
Lifting handle	Check its condition and replace if necessary.
Rotation direction	Check impeller/propeller rotation direction.
Pump station	Intermediate Service 5 000 working hours/Once a year
Lifting device	Check that local safety regulations are followed.
Electrical cabinets/panels	Check that they are clean and dry.
Connection to power	Check the cable connections. Tighten if necessary.
Overload and other protections	Check settings.
Personnel safety	Check guard rails, covers and other protections.
Level regulators	Check condition and function.

Pump	Major Service 25 000 working hours/Every 5 year
Isolation check	Check that the resistance between earth and phase lead is more than 5 M w.
Cable	Check that the rubber sheathing (jacket) is undamaged. Change if necessary.
Oil housing	Drain the oil.
Dismantling and cleaning	Total dismantling of the pump. Cleaning of all parts.
Bearings	Replace.
O-rings and other rubber sealing parts	Replace.
Reassembly	Reassemble the pump.
Seals	Replace.
Sensors	Check stator temperature, bearing temperature and FLS/CLS sensors. For details, see "Service instructions".
Oil	Fill new oil.
Impeller/Propeller	Check general impeller/propeller and wear ring status. Change if necessary.
Zinc anodes	Check and change if necessary.
Screw joints	Check all externally accessible screw joints and tighten if necessary to correct torque. See torque table and parts list.
Lifting handle	Check its condition and replace if necessary.
Painting	Touch up painting if necessary.
Rotation direction	Check impeller/propeller rotation direction.
Voltage and amperage	Check running values.

Pump station	Major Service 25 000 working hours/Every 5 year
Lifting device	Check that local safety regulations are followed.
Electrical cabinets/panels	Check that they are clean and dry.
Connection to power	Check the cable connections. Tighten if necessary.
Overload and other protections	Check settings.
Personnel safety	Check guard rails, covers and other protections.
Level regulators	Check condition and function.

Safety precautions



WARNING!

Before starting work on the pump, make sure that the pump is isolated from the power supply and cannot be energized.

NOTE!

This applies to the control circuit as well.

Follow all health and safety rules and local codes and ordinances.



NOTE!

Before starting service on the pump, make sure that the motor has cooled down sufficiently to carry out the service work.

Tightening torques

The torque values in the table below should be used unless otherwise stated. Refer also to cross-sectional drawing in the parts list for torque values.

RECOMMENDED TIGHTENING TORQUE FOR FLYGT'S STANDARD SCREWS IN Nm AND ft-lb

Chart valid only for lubricated screws. Mineral oils for non stainless screws. Use oils such as 90 18 00 for stainless screws.

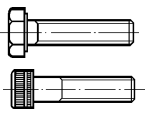
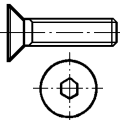
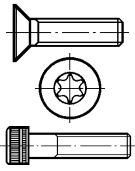
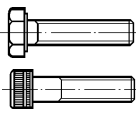
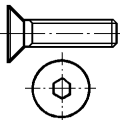
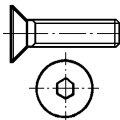
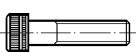
Material Thread	Stainless (A2, A4)						Non stainless							
	Property class						Property class							
	70		80		8.8		8.8		10.9		12.9			
	Nm	ft-lb	Nm	ft-lb	Nm	ft-lb	Nm	ft-lb	Nm	ft-lb	Nm	ft-lb	Nm	ft-lb
M5	4,1	3	2,0	1,5	5,4	4	5,7	4,2	4,6	3,4	6,5	4,8	9,7	7,2
M6	7	5,2	4,1	3	9,3	6,9	9,8	7,2	7,8	5,8	11	8	17	12,5
M8	17	12,5	7	5,2	22	16	24	18	19	14	26	19	40	30
M10	33	24,3	17	12,5	44	32	47	35	38	28	52	38	79	58
M12	57	42	33	24,3	76	56	81	60	65	48	91	67	136	100
M16	140	103	57	42	187	138	197	145	158	116	222	164	333	245
M20	273	201	100	74	364	268	385	285	308	228	433	320	649	480
M24	472	348	140	103	629	464	665	490	532	392	748	552	1120	825
Type of screw														

Service instructions

Intermediate service

DRIVE UNIT

- Check the whole pump and the cables for external mechanical damage.
- Open all inspection covers (for the junction box and the sensors).



CAUTION! Inside may be pressurized! Make sure that the cooling jacket is drained before service work is started. See "Installation, Cooling system".

The cooling jacket has two inspection covers.

They are to be used for cleaning of the cooling jacket and to give access to the inspection cover(s) on the stator housing and the sensors behind these.

For 600, 700 and 800 series drive units the sensors are accessible behind the inspection cover marked "SENSORS".

Note! These drive units have only one inspection cover on the stator housing.

For 900 series drive units the standard sensors are accessible behind the inspection cover marked "SENSORS A".

Additional sensor, i.e. CLS 30 is accessible behind the inspection cover marked "SENSORS B".

- Check that the inside is dry and clean. No moisture or oil should be present.
- Check the insulation resistance from phase to earth and phase to phase.

NOTE! ONLY POWER CABLES.

Use a 1000 V-DC megger. The insulation between the phases and between any phase and earth (ground) should be above 50 MΩ, and in any case not lower than 5MΩ. Keep a record of the results.

- Check that the leads are correctly connected to the terminals and that these are tightened to the correct torque.
- Check that the cable entry screws are tightened to the correct torque.
- Check all sensors (as applicable). See "Connection of monitoring equipment".

NOTE!

Never insert measuring probes into the sensor contacts or sockets during measuring or checking as these may be deformed and cause a "loose" contact when the ordinary plug is connected.

Drive units 605, 665, 705, 735, 765, 805, 835, 865, 905, 925, 935, 955 and 965

1. Stator winding temperature

For monitoring of stator winding temperature there are three alternative methods where alternative "A" is standard. The other alternatives are available on request. For the high voltage drive units 925 and 955, only alternative "C" is available.

- A. The coil ends of the stator winding incorporate three thermal switches connected in series. The switches are normally closed and open at 140°C (285°F).
- B. The coil ends of the stator windings incorporate three thermistors connected in series.

$T_{Ref}=140^{\circ}\text{C}$ (285°F).

Alternative "A" and "B" are connected to connections 51-61, 52-62, 53-63 on terminal block 1.

Use a multimeter set for measuring ohms. The PTC-Thermistor gives a certain resistance at room temperature (approx. 50 to 100 ohms). As the temperature increases the resistance also increases gradually but above a certain level the resistance rises dramatically (up to several kohms). If broken circuit condition is established always check the contacts and leads first.

NOTE! The thermistors may not be connected to a higher voltage than 2.5V.

- C. The coil ends of the stator windings incorporate three Pt 100 platinum transducers, one for each phase, connected individually to connections 19-20, 21-22, 23-24 on terminal block 2. This alternative (not for 925 and 955 drive units) also includes thermal switches according to "A".

Use a multimeter set for measuring ohms. Check the resistance and compare the value in the table for Pt-100 sensors at actual temperature. Make sure it corresponds approx. with the table value. See page 24. If broken circuit condition is established always check the contacts and leads first.

2. Stator housing leakage

A float switch in the lower part of the stator housing reacts if liquid enters the stator housing.

Resistance: normal 1500 ohms
 at alarm 330 ohms

Connected to connections 1 and 2 on terminal block 1.

Use a multimeter and measure the resistance value of the sensor. If the sensor is inaccessible it is only necessary to measure one of the values.

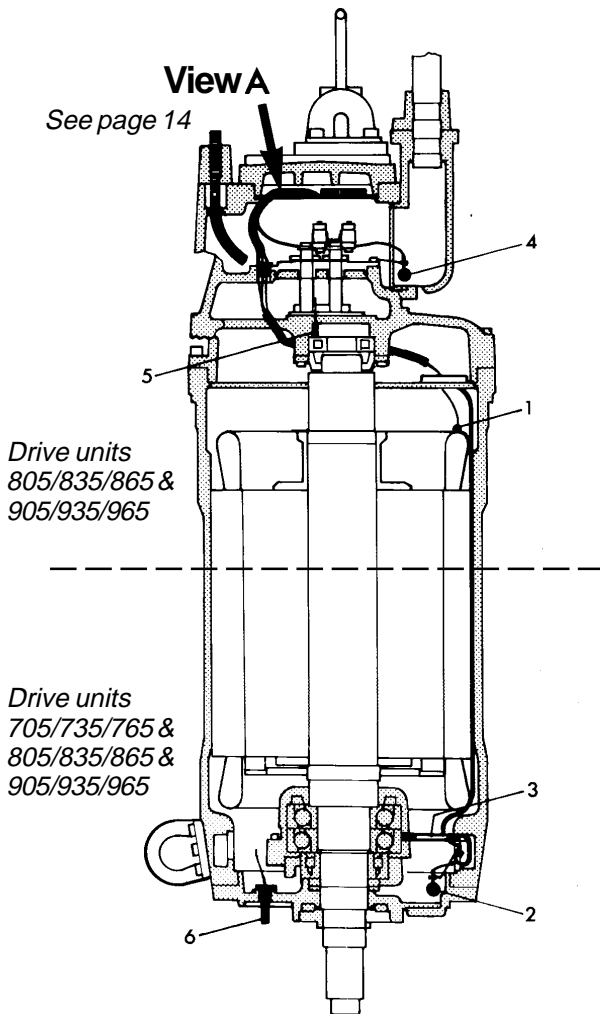
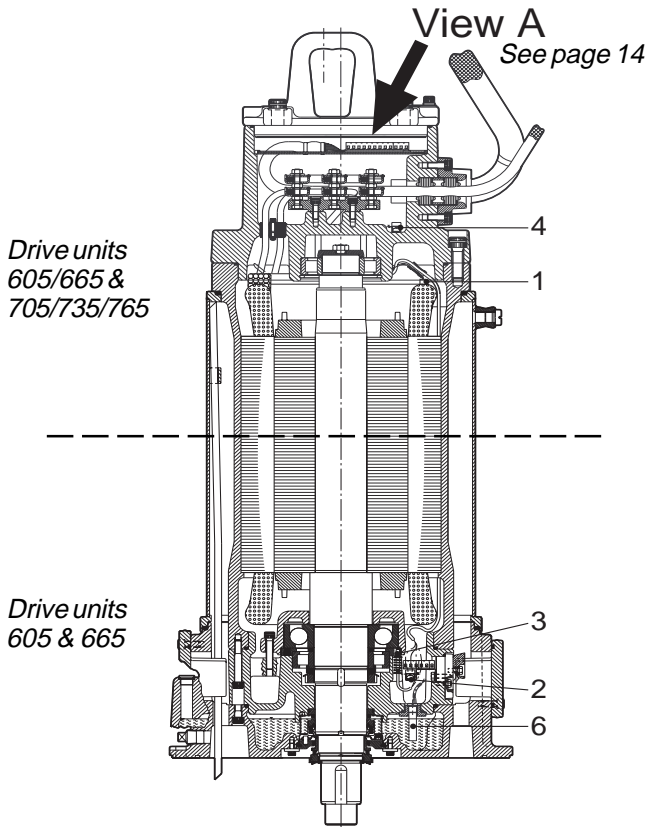

3. Main bearing (lower bearing) temperature

A platinum transducer (Pt 100) at the lower bearing monitors the bearing temperature.

Resistance according to table, page 24.

Connected to connections 3 and 4 on terminal block 1.

NOTE! The Pt 100 transducer may not be connected to a higher voltage than 2.5 V.

4. Junction box leakage

A float switch in the junction box reacts if leakage occurs in the junction box.

Connected to connections 9 and 10 on terminal block 1.

5. Support bearing (upper bearing) temperature

A platinum transducer (Pt 100) at the support bearing monitors the bearing temperature.

Resistance according to table, page 24.

Connected to connections 37 and 38 on terminal block 1. (Not available for the 605 and 665 drive units).

6. Oil housing leakage

A capacitive leakage sensor (CLS) in the oil housing issues an alarm if the water content reaches a concentration of 30%.

Connected to connections 33 and 34 on terminal block 2.

CLS-30 can only be checked when it is connected to a 12V DC supply e.g. CAS. To enable the sensor to be checked it must have the correct polarity. It will not however be damaged if plus and minus are switched.

Use the multimeter as an ammeter and connect it in series with the sensor.

Method: If the sensor is accessible the alarm function can be checked by gripping the sensor in your hand. Skin tissue and blood contain a high content of water.

Result	
0 mA	Can indicate one of the following conclusions: 1: Sensor has the wrong polarity: check by changing over plus and minus. 2: Breakage in the cable / lead.
4.0 - 8.0 mA	Normal No-alarm current
27 to 33 mA	Normal Alarm current

NOTE!

CLS has a 5 second delay before the alarm current, signalling leakage, is initiated. A further 5 second alarm delay in the CAS unit, before the red LED (signal lamp) lights to indicate leakage, results in a 10 second delay before alarm status is registered on the monitoring unit.

EX-Drive units 615, 675, 715, 745, 775, 815, 845, 875, 915, 945 and 975

1. Stator winding temperature

For monitoring of stator winding temperature alternative "A" is standard for EN and FM-approved drive units. Alternative "B" is only available for FM-approved drive units and on request.

- A. The coil ends of the stator winding incorporate three thermal switches connected in series. The switches are normally closed and open at 140°C (285°F).
- B. The coil ends of the stator windings incorporate three thermistors connected in series.

$T_{Ref}=140^{\circ}\text{C}$ (285°F).

Alternative "A" and "B" are connected to connections 51-61, 52-62, 53-63 on terminal block 1.

Use a multimeter set for measuring ohms. The PTC-Thermistor gives a certain resistance at room temperature (approx. 50 to 100 ohms). As the temperature increases the resistance also increases gradually but above a certain level the resistance rises dramatically (up to several kohms). If broken circuit condition is established always check the contacts and leads first.

NOTE! The thermistors may not be connected to a higher voltage than 2.5 V.

2. Stator housing leakage

A float switch in the lower part of the stator housing reacts if liquid enters the stator housing.

Resistance: normal 1500 ohms
at alarm 330 ohms

Connected to connections 1 and 2 on terminal block 1.

Use a multimeter and measure the resistance value of the sensor. If the sensor is inaccessible it is only necessary to measure one of the values.

3. Main bearing (lower bearing) temperature

A platinum transducer (Pt 100) at the lower bearing monitors the bearing temperature.

Connected to connections 3 and 4 on terminal block 1.

Use a multimeter set for measuring ohms. Check the resistance and compare the value in the table for Pt-100 sensors at actual temperature. Make sure it corresponds approx. with the table value. See page 24. If broken circuit condition is established always check the contacts and leads first.

NOTE! The Pt 100 transducer may not be connected to a higher voltage than 2.5 V.

4. Junction box leakage

A float switch in the junction box reacts if leakage occurs in the junction box.

Connected to connections 9 and 10 on terminal block 1.

5. Support bearing (upper bearing) temperature

A platinum transducer (Pt 100) at the support bearing monitors the bearing temperature.

Resistance according to table, page 24.

Connected to connections 37 and 38 on terminal block 1.

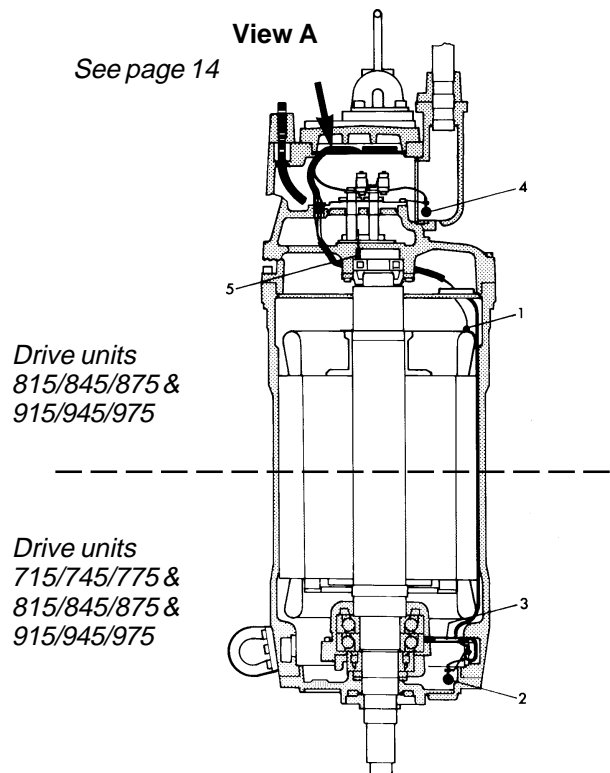
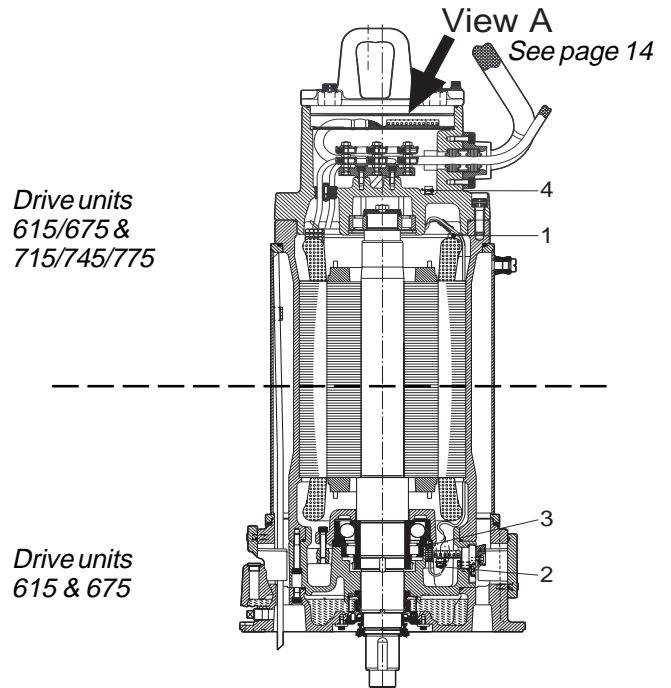

Pt 100, Temperature/resistance relationship

$$R(0) = 100,00 \Omega \quad \alpha = 0,003\ 850$$

°C EIPT-68	0	1	2	3	4	5	6	7	8	9	10	°C EIPT-68
0	100,00	100,39	100,78	101,17	101,56	101,95	102,34	102,73	103,12	103,51	103,90	0
10	103,90	104,29	104,68	105,07	105,46	105,85	106,24	106,63	107,02	107,40	107,79	10
20	107,79	108,18	108,57	108,96	109,35	109,73	110,12	110,51	110,90	111,28	111,67	20
30	111,67	112,06	112,45	112,83	113,22	113,61	113,99	114,38	114,77	115,15	115,54	30
40	115,54	115,93	116,31	116,70	117,08	117,47	117,85	118,24	118,62	119,01	119,40	40

--- Reassemble all inspection covers.

NOTE! Always fit new O-rings.

--- Check the zinc anodes (if applicable) to make sure they are large enough and intact. Replace after approx. 75% consumption.

--- Check that all screws are tightened to the correct torque according to specifications in parts list.

Changing the oil



WARNING.
The oil housing may be pressurized.
Hold a rag over the oil plug to prevent oil spraying out.

Unscrew the oil housing plugs. Pump out the oil using oil drainage pump 83 95 42 or the equivalent. Make sure that the plastic tube goes all the way to the bottom of the oil housing.

Fill up with new oil. The oil housing contains the following amounts of oil depending on which drive unit is used:

Pumps with cooling jacket

- 6x5 series drive units 4.5 litres (4.7 US quarts)
- 7x5 series drive units 5.5 litres (5.8 US quarts)
- 8x5 series drive units 11 litres (11.6 US quarts)
- 9x5 series drive units 9 litres (9.5 US quarts)

Pumps without cooling jacket

The volume of the oil housing is depending on which hydraulic unit the drive unit is combined with.

Volume values in litres (US quarts)

Drive unit	Volume	Hydraulic unit CP-version
6x5, 7x5	5.2 (5.5)	3300, 3231, 3306, 3356
7x5, 8x5	11.5 (12.1)	3312, 3400
8x5	8.4 (8.9)	3501, 3531, 3602
9x5	9.0 (9.5)	3351, 3531, 3602, 3800

The pumps are delivered from the factory with a tasteless and odourless paraffin oil suitable for raw- or clean-water applications. This oil is authorized according to FDA 172.878.

Oil type Mobil Whiterex or Shell Ondina etc. with viscosity class ISO VG 15 to 32 can be used.

Check that the oil reaches up to the oil holes. The pump should be standing vertically.

Always replace the O-rings of the oil plugs. Put the plugs back and tighten them. Tightening torque 80 Nm (60 ft lb).

--- Check the paint; if damaged, repaint.



HYDRAULIC UNIT

Replacing the wear parts in the hydraulic unit

When the clearance between the impeller skirt and the pump housing wear ring exceeds 2 mm (0.08 in), one or more of the following replacements must be made.

Replacing the wear ring in the suction cover/pump housing.

Two sets of lifting equipment are required to handle the pump for repair work.



WARNING!

For personal safety reasons and to avoid damage to the impeller, seals or bearings the drive unit must **never** be placed on the shaft end or the impeller.

Use the lifting method below.

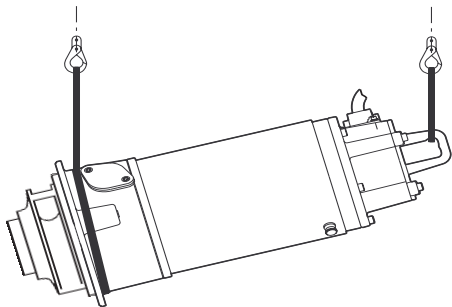

Drive units 605 — 775

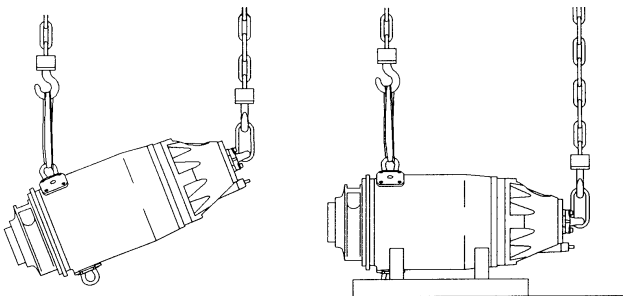

Drive units 805 — 975

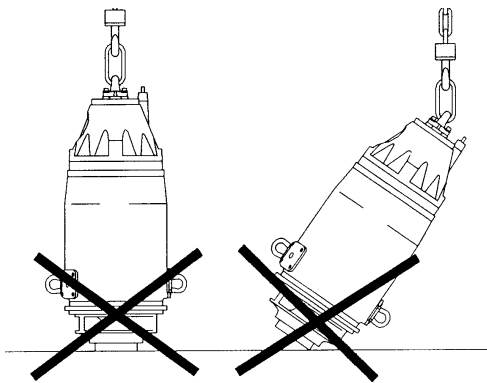

Disconnect and lift off the drive unit from the pump housing. Lay the drive unit on its side. Make sure it cannot roll.

Remove the wear ring using a crow bar.

Drive in the new wear ring. Use a rubber mallet or wooden block to prevent deformation.

The work will proceed more easily if the suction cover/pump housing is first heated and/or the wear ring cooled. This is only applicable when the wear ring is made of brass.

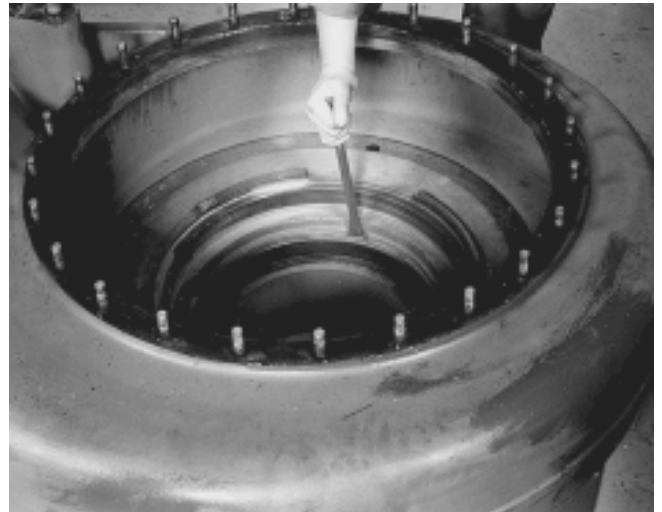

Replacing the impeller wear ring.

Disconnect and lift off the drive unit from the pump housing.

Lay the drive unit on its side. Make sure it cannot roll.

Knock off the wear ring from the impeller. If necessary, saw grooves in the wear ring using a hacksaw.

Heat the new wear ring and press it onto the impeller.



Replacing the impeller

When replacing the impeller the mechanical face seal should be replaced to ensure maximum sealing properties. Use a Flygt new or factory reconditioned mechanical face seal unit. This work require special tools and should be carried out by a service technician authorized by Flygt.

Drain the oil in the oil housing. See "Changing the oil".

Removing the impeller



WARNING! Worn impellers often have very sharp edges.

Disconnect and lift off the drive unit from the pump housing.

Lay the drive unit on its side. Make sure it cannot roll.

The removal procedure is different depending on which pump the impeller is to be removed from.

C3300/6x5 LT & MT, C3231, C3306, C3356

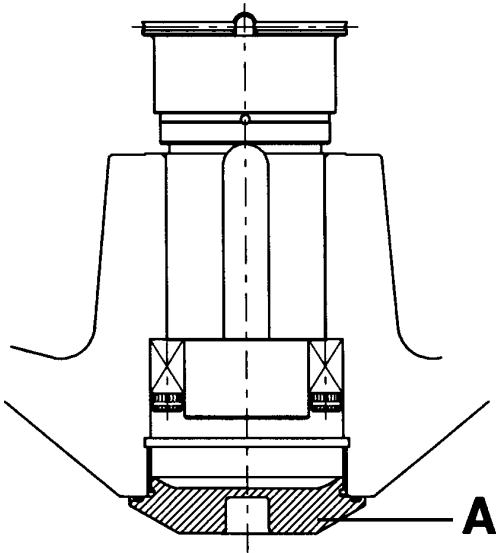

For C3300/6x5 LT & MT, remove the centre screw in the impeller sealing washer.

For C3231, C3306, C3356, remove the impeller sealing washer (A) using the allen key hole in the washer. The washer is threaded into the impeller hub. Use a 19 mm allen key.

C3300/6x5 HT

To remove the impeller the pump housing should still be connected to the drive unit. The impeller for this version is fitted to a hub with two screws.

Lay the pump on its side and make sure it cannot roll.

Remove the screws for the suction cover and replace 3 of the screws with the longer screws 813963 (M16 x 160).

Push out the suction cover and place a distance block between the pump housing and the suction cover, (min distance=30 mm).

Remove the two screws for the impeller.

Apply the puller unit 4917400 acc. to picture and pull off the impeller. Remove the suction cover and the impeller.

Disconnect and lift off the drive unit from the pump housing.

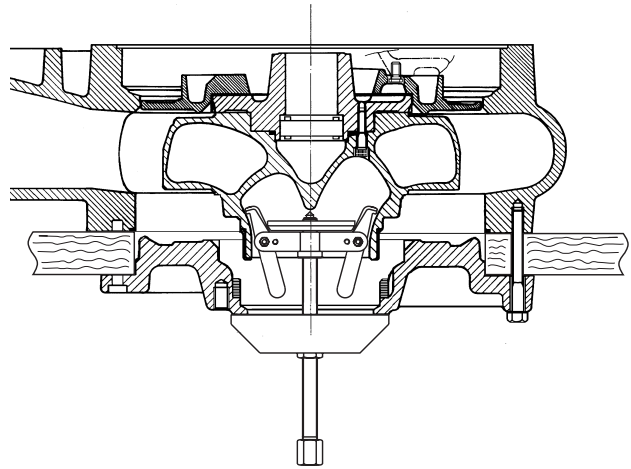

The locking assembly (84 59 12) is now accessible for removal.

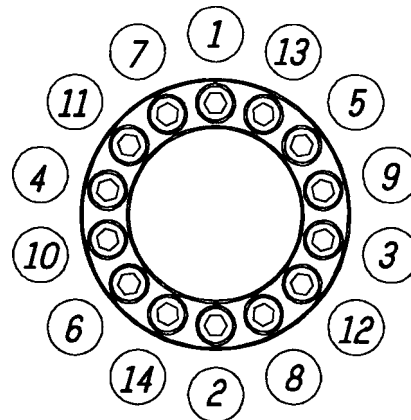

84 59 12 (for shaft end \varnothing 70 mm)

R3231

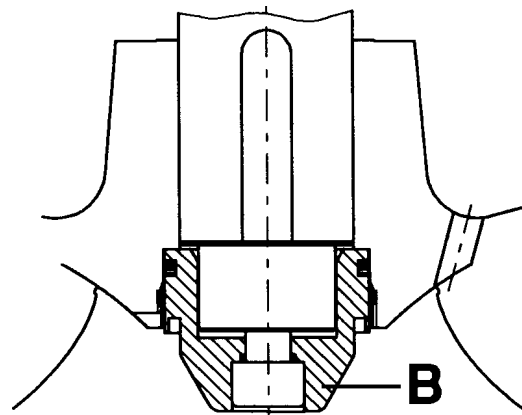

Remove the sealing washer unit (B). Use a 17 mm allen key for removal. This version has no locking assembly and the impeller is now ready for removal.

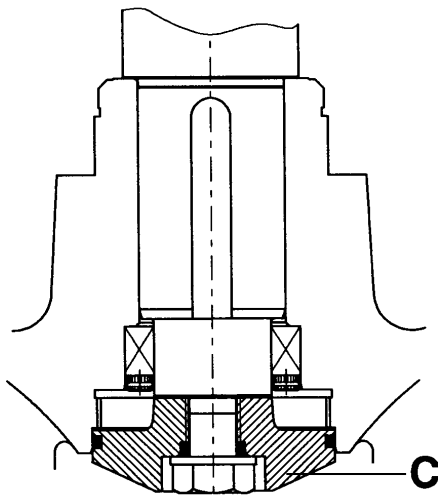

Remove the impeller screw. Insert the puller screw 576 84 00 in the thread of the impeller sealing washer (C) to remove it.

The locking assembly (84 59 13, 84 59 14, 84 59 17, 84 60 11) is now accessible for removal.

Removal of the locking assembly

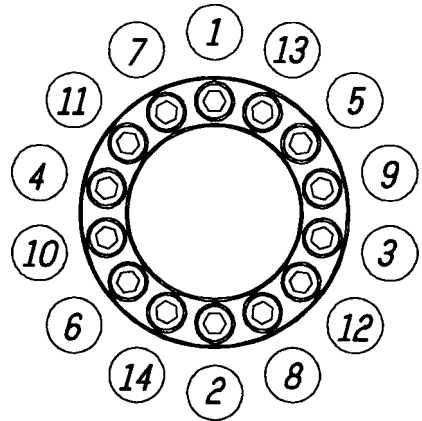

84 59 13 (for shaft end Ø 75 mm)

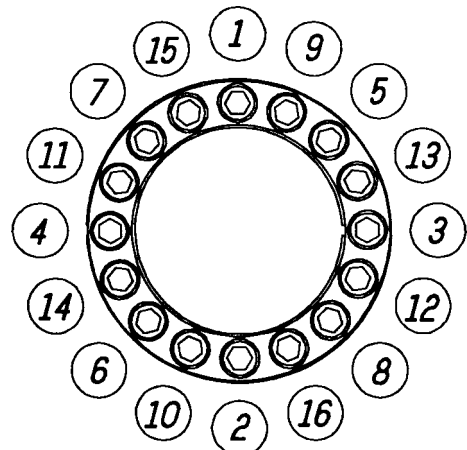

84 59 14 (for shaft end Ø 90 mm)
84 59 17 (for shaft end Ø 110 mm)

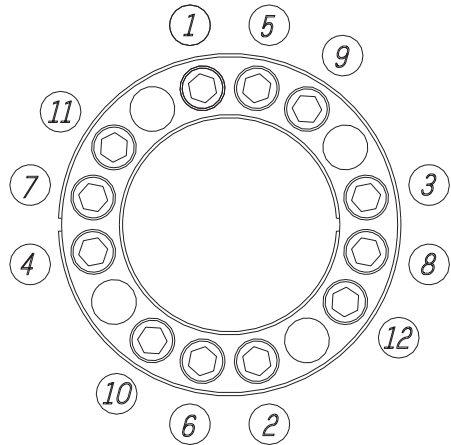

84 60 11 (for shaft end Ø 110 mm) C3800



Loosen the screws on the locking assembly evenly in a diagonal pattern and in sequence according to the pictures. If the locking assembly is still locked proceed as follows:

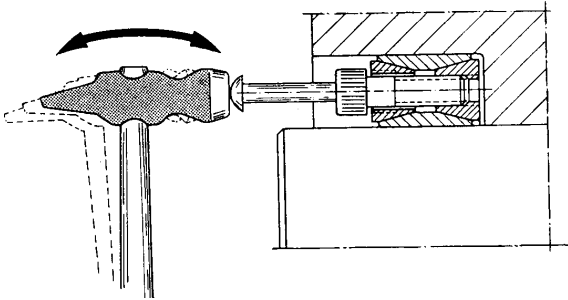

C3231-C3602

--- Loosen the inner ring by tapping it lightly, as shown in the picture. If this does not result in the loosening of the ring, proceed with next method.

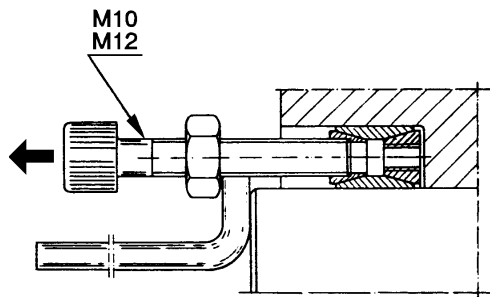

--- Replace the three light-coloured screws with three M10 draw-bolts for 84 59 12 and 84 59 13 or M12 draw-bolts for 84 59 14 and 84 59 17.

C3800

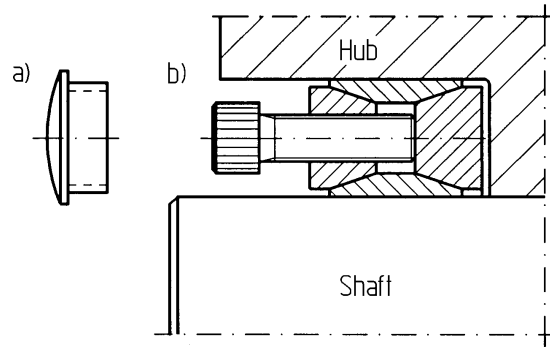

--- Remove the four plastic plugs a) covering the threaded holes for the special separation-screws.
 --- Loosen the inner ring by means of the four separation-screws (M14) as shown in the picture.

Remove the locking assembly.



Fit the tools required for impeller removal according to tool list for appropriate pump, see "Tools". Use the hydraulic tool with the partially threaded screw in the Basic kits for removal. For C3800, use screw unit 602 31 00.

Pull off the impeller.

Installing the impeller

Note!

When installing stainless steel impeller onto stainless steel shaft, the shaft end should be greased with Aral Degol GS 1500. Make sure that no grease is on the contact surfaces of the locking assembly.

Make sure that the end of the shaft is clean and free of burrs. Polish off any flaws with fine emery cloth.

Grease end of shaft and impeller hub.

C3300/6x5

Place the impeller/impeller hub on the shaft and press it onto the shaft with the impeller screw.

For C3300/6x5 HT, press the hub onto the shaft.

C3231, C3306, C3356

Place the impeller on the shaft and fit the hydraulic tool with the screw with the M16 threaded end. Use also the appropriate washer to press the impeller in place. Remove the hydraulic tool.

Installing the locking assembly

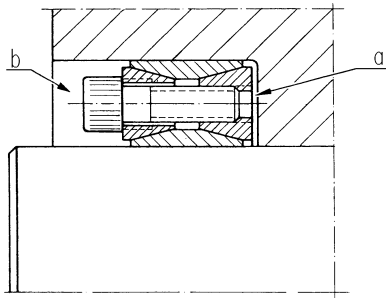

Apply a thin layer of grease at "a", see fig.

Fit the locking assembly (well oiled) in the impeller hub without tightening any screws.

Oil containing Molybdenum disulphide (MoS_2) should not be used.

C3300/6x5

Tighten the screws manually in sequence all around until the locking assembly keeps the impeller/impeller hub in place.

C3231, C3306, C3356

Place the washer 576 83 00 over the locking assembly. For right position, use an allen key through one of the slots in the washer and into one of the light-coloured screws in the locking assembly. Fit the screw 84 34 30 (M20 x 60 mm, included in 588 92 00) through the centre hole in the washer and into the shaft end.



Tighten the centre screw, and the washer keeps the locking assembly and the impeller in place.



When the impeller is firmly seated, slightly tighten the three light-coloured screws in the locking assembly through the slots in the washer. This keeps the impeller in place against the shaft shoulder.

Remove the centre screw and the washer.

C3312, C3351, C3400, C3501, C3531, C3602, C3800

Use the same procedure as for C3231, C3306, C3356 but use washer 576 83 01-04 instead and the impeller screw for each respective pump. For C3800, use washer 584 81 01. See "Tools".

Tighten the locking assembly screws evenly in three stages, in a diagonal pattern and in sequence according to the pictures and table below.

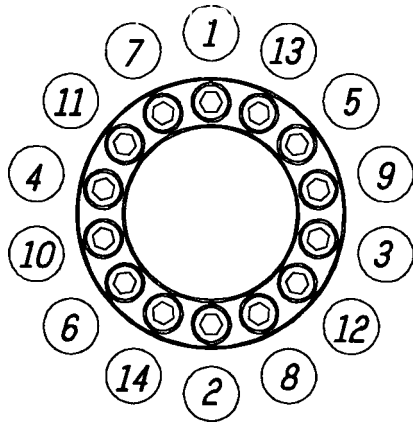

84 59 12 (for shaft end Ø70 mm)

84 59 13 (for shaft end Ø75 mm)

Stage	Torque
Stage 1	12 Nm (8.8 ft lb.)
Stage 2	24 Nm (18 ft lb.)
Stage 3	35 Nm (26 ft lb.)

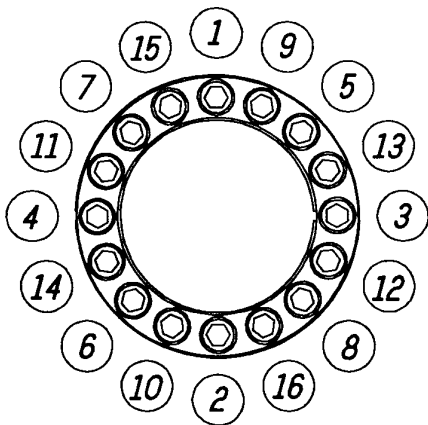

84 59 14 (for shaft end Ø90 mm)

84 59 17 (for shaft end Ø110 mm)

Stage	Torque
Stage 1	24 Nm (18 ft lb.)
Stage 2	48 Nm (35 ft lb.)
Stage 3	70 Nm (52 ft lb.)

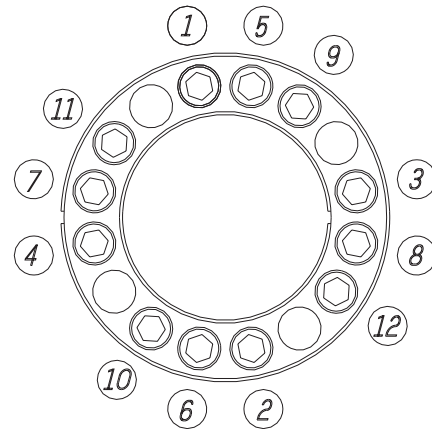

84 60 11 (for shaft end Ø110 mm) C3800

Stage	Torque
Stage 1	70 Nm (52 ft lb.)
Stage 2	154 Nm (113 ft lb.)
Stage 3	230 Nm (170 ft lb.)

Fill the space "b" with grease allowing space for sealing washer.

Fit the impeller sealing washer and tighten the impeller screw. For C3300/6x5 HT, place the impeller onto the impeller hub and fit the two screws holding the impeller. Tighten to correct torque.

Check that the impeller can be rotated by hand.

Check the zinc anodes (if applicable) to make sure they are large enough and intact. Replace after approx. 75% consumption.

Fit the drive unit to the pump housing. Make sure that the pump housing has the right orientation.

Don't forget the O-ring between pump housing and drive unit.

More extensive repairs require special tools and should be carried out by a service technician authorized by Flygt.

Tools

Besides ordinary standard tools, the following special tools (available on order from Flygt) are required in order to perform the necessary care and maintenance of the pump:

Order No.	Description
83 95 42	Oil drainage pump
84 13 68	Hydraulic unit
R3231	
436 19 00	Basic kit II
436 74 00	Impeller tool
C3300/6x5 LT	
84 20 49	Puller
479 23 00	Extension
479 25 00	Washer
C3300/6x5 MT	
400 54 03	Dismount./lifting tool (for imp. x41, x42)
400 54 05	Dismount./lifting tool (for imp. x32)
C3300/6x5 HT	
81 39 63	Screw (3 pcs)
491 74 00	Puller unit
C3231, C3306, C3356	
432 43 00	Washer (included in Basic kit II)
436 19 00	Basic kit II
436 74 00	Impeller tool
588 92 00	Mounting washer unit
C3312, C3400, C3501	
332 91 00	Stop spring remover
399 41 00	Mounting tool set for seal (for shaft Ø75 mm and Ø90 mm)
576 83 01	Washer (for shaft Ø75 mm, 700 drive units)
576 83 02	Washer (for shaft Ø90 mm, 800 drive units)
576 84 00	Puller screw
584 81 00	Washer
587 72 00	Impeller tool (for shaft Ø75 mm and Ø90 mm)
587 94 00	Basic kit V
C3351	
576 83 04	Washer
576 84 00	Puller screw
584 81 00	Washer
587 73 00	Impeller tool (for shaft Ø110 mm)
587 94 00	Basic kit V

C3531, C3602

332 91 00	Stop spring remover
399 41 00	Mounting tool set for seal (for shaft Ø75 mm and Ø90 mm)
576 83 01	Washer (for shaft Ø75 mm, 700 drive units)
576 83 02	Washer (for shaft Ø90 mm, 800, 905 & 915 drive units for 3531, 8-pole; 3602, 8-pole)
576 83 03	Washer (for shaft Ø110 mm, 905 & 915 drive units with 10-pole motors; 935 & 945 drive units)
576 84 00	Puller screw
584 81 00	Washer
587 72 00	Impeller tool (for shaft Ø75 mm, 700 drive units and for shaft Ø90 mm, 800, 905 & 915 drive units for 3531, 8-pole; 3602, 8-pole)
587 73 00	Impeller tool (for shaft Ø110 mm, 905 & 915 drive units with 10-pole motors; 935 & 945 drive units)
587 94 00	Basic kit V
C3800	
576 84 00	Puller screw
584 81 01	Washer
589 23 00	Screw unit (mounting)
602 18 00	Impeller tool
602 31 00	Screw unit (removal)

For further information on tools, see Flygt's Tool Catalogue.

Inspection on site

Before installation:

- Check the guide bars.
- Check the discharge connection for damage and obstructing materials.
- Check the function of the level sensors.

Install the pump.

Starter equipment

All electrical work shall be carried out under the supervision of an authorized electrician.



Follow local safety regulations and observe recommended safety precautions.

- Check the starter equipment according to manufacturer's maintenance plan.

Note! Check all alarm functions.

Testing

- Measure all electrical values.
- Check that the machine is working without noise or vibration. Note any abnormalities.
- Check that all accessories are working properly. Note any abnormalities.



www.flygt.com