

WORKSHOP MANUAL



Products included

3085.182:	Standard
3085.092:	EEx d IIB T4 FM: Class I Div. 1 Grp. C and D Class II Div. 1 Grp. E, F and G Suitable for use in Class III Div. 1
3085.172:	Grinder Standard
3085.891:	Grinder EEx d IIB T4 FM: Class I Div. 1 Grp. C and D Class II Div. 1 Grp. E, F and G Suitable for use in Class III Div. 1
3102.180:	Standard
3102.090:	EEx d IIB T4 FM: Class I Div. 1 Grp. C and D Class II Div. 1 Grp. E, F and G Suitable for use in Class III Div. 1
3102.170:	Grinder Standard
3102.890:	Grinder EEx d IIB T4 FM: Class I Div. 1 Grp. C and D Class II Div. 1 Grp. E, F and G Suitable for use in Class III Div. 1
3127.180:	Standard
3127.090:	EEx d IIB T4 FM: Class I Div. 1 Grp. C and D Class II Div. 1 Grp. E, F and G Suitable for use in Class III Div. 1
3127.170:	Grinder Standard
3127.890:	Grinder EEx d IIB T4 FM: Class I Div. 1 Grp. C and D Class II Div. 1 Grp. E, F and G Suitable for use in Class III Div. 1

How to use the workshop manual

This workshop manual describes how to dismantle and assemble products 3085, 3102 and 3127 in connection with repair and reconditioning work. The operative part of the manual begins with numbered illustrations of different work operations. At the end of the manual there are fold-out sheets with a description of the operations. Also in the end you will find exploded views of the different pump models.

Most of the operations apply to all three pump types. However, in some procedures the instructions may differ between the pumps. Here we have pointed this out with a picture or explained this in the text.

Details are also provided of the special tools which not only facilitate repair work, but which are sometimes necessary in order to carry out a particular operation.

We would also point out that the practical work involved in compiling this manual has been performed under extremely favourable conditions. We have dismantled and assembled new products. A pump which has been in use for a longer period of time has acquired a "patina" and other working methods besides those recommended here will sometimes have to be used.

If the pump is specially approved, please read the chapter "Specially approved pumps" in the end of this manual.

Flygt disclaims all responsibility for work done by untrained, unauthorized personnel.

CONTENTS

Products included	2
How to use the workshop manual	3
Safety precautions	5
General rules	5
How to read the data plate	6
General data plate	6
Approval plates	7
EN data plate	7
FM data plate	7
Technical data	8
Weights	8
Tightening torques	8
Special tightening torques	8
Lubricants	9
Special tools	9
Electrical connections	12
Monitoring equipment	12
Stator lead colours	12
3-phase, direct on-line starting	13
3-phase, star-delta starting	14
Single phase	15
Notes	16
Dismantling / assembly, pictures	19
Mechanical face seal descriptions	30
Dismantling, text descriptions	48
3085 Cable connection	48
3102 and 3127 Junction box	48
Dismantling the impeller and outer seal unit	48

Contents

Dismantling the oil casing and inner seal unit.	48
Exploded views 3085, 3102, 3127	49
Dismantling the upper and lower bearings.	52
Assembly	52
Assembling the stator with stator housing, upper and lower bearings.	52
Assembling the inner seal unit and oil housing.	52
Assembling the outer seal unit.	56
3085 Cable connection.....	56
3102 and 3127 junction box.	56
Assembling the stator housing.	56
Assembling the impeller.	60
Replacing the wear ring.	60
Grinder. Replacing the impeller and the grinder device.	60
Replacing and adjusting the F type impeller.	64
Replacing the impeller of swirl (vortex) type.	64
Specially approved pumps	67
General	67
Workshop repair	67
Guidelines for repair	67
Flamepaths	68
Stator and rotor	69
Dimensional checks	70

Safety precautions

In order to minimize the risk of accidents in connection with service work, the following rules should be followed:



1. Before starting work on the pump, make sure that the pump is isolated from the power supply and cannot be energized.
2. Bear in mind the risk of accidents. Make sure that the machine or parts of the machine can not fall over.
3. Make sure that the lifting equipment can handle the weight you want to lift and that it is in good condition.
4. Make continuously sure that in the course of the work the pump and / or pump components stand steadily and cannot fall down and cause damage.
5. Don't work under suspended load.
6. Carry out the work on a sturdy work bench.
7. Bear in mind the danger of electrical accidents.
8. Bear in mind health hazards. Observe strict cleanliness. When carrying out repair work take care to avoid injury by cutting or pinching.
9. Make sure you have a first-aid box near at hand.
10. Check that tools and other equipment are in good condition.

Follow all other health and safety regulations, local codes and ordinances.

See also the Installation, Care and Maintenance manual, chapter "Installation, safety precautions"

General rules

Wash the outside of the pump thoroughly and blow it dry.

Clean all parts thoroughly - particularly O-ring grooves - before assembly.

Always change all O-rings, other seals and gaskets and lock washers.

Lubricate moving parts, O-rings and shaft seals.

How to read the data plate

General data plate

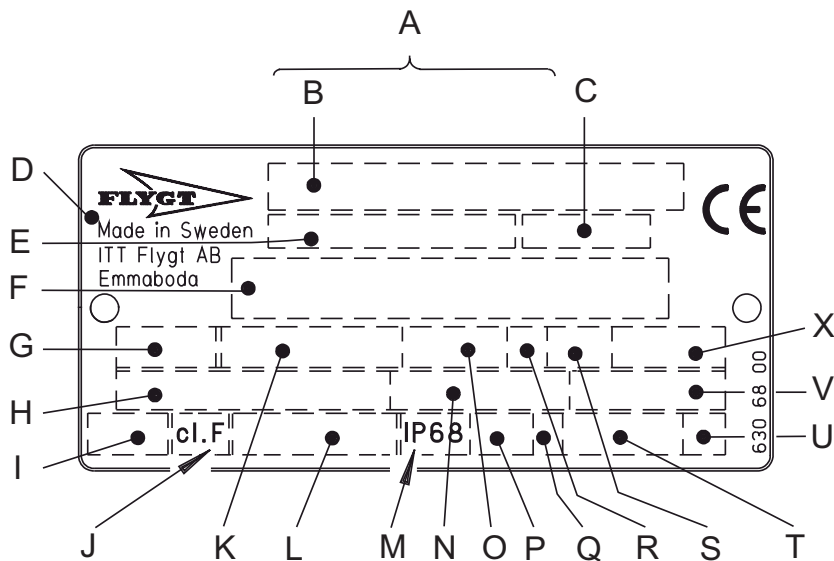

Data plate interpretation

- A Serial number
- B Product code + Number
- C Curve code / Propeller code
- D Country of origin
- E Product number
- F Additional information
- G Phase; Type of current; Frequency
- H Rated voltage
- I Thermal protection
- J Thermal class
- K Rated shaft power
- L International standard
- M Degree of protection
- N Rated current
- O Rated speed
- P Max. submergence
- Q Direction of rotation: L=left, R=right
- R Duty class
- S Duty factor
- T Product weight
- U Locked rotor code letter
- V Power factor
- X Max. ambient temperature

How to read the data plate

Approval plates; always together with the general data plate

EN data plate

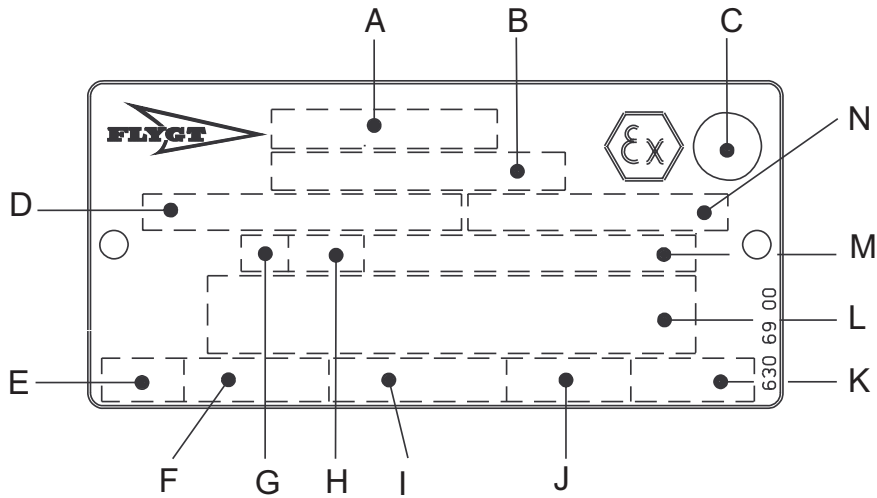

Approval plate

- A Approval
- B Approval authority + Approval Number
- C Approval for Class I
- D Approved drive unit
- E Stall time
- F Starting current / Rated current
- G Duty class
- H Duty factor
- I Input power
- J Rated speed
- K Controller
- L Additional information
- M Max. ambient temperature
- N Serial number

FM data plate

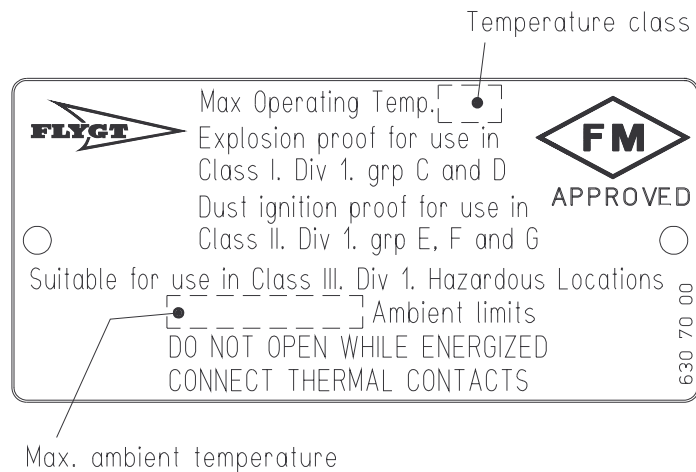

Technical data

Weights

The weight varies depending on the version:

3085	44 - 80 kg	(97 - 176 lb)
3102	75 - 159 kg	(165 - 350 lb)
3127	103 - 221 kg	(227 - 487 lb)

For the pump's specific weight, current, voltage, power ratings and speed, please refer to the data plate of the pump.

Tightening torques

Recommended tightening torques for Flygt's standard screws.

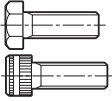
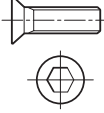
Material Thread	Stainless (A2, A4)			
	Property class			
	70			
	Nm	lb ft	Nm	lb ft
M5	4.1	3	2.0	1.5
M6	7	5.2	4.1	3
M8	17	5.2	4.1	3
M10	33	24.3	17	12.5
M12	57	42	33	24.3
M16	140	103	57	42
M20	273	201	100	74
M24	472	348	140	103
Type of screw				

Special tightening torques:

	3085	3102 (Nm)	3127
Impeller screw	34	33	57
Impeller screw, F version	30	33	40
Oil, (inspection) screws	20	20	20

Technical data

Lubricants

Lubricate all **screws** with oil before assembly.

Part No Description

90 17 52 Oil for the oil housing; Paraffin oil Mobil Whiterex 307-309, (alternative: Esso Marcol 82, Shell Ondina or similar oil which meets the standard FDA 172.878).
Oil volume; **0.9 l for 3085, 1.0 l for 3102, 2.25 l for 3127.**

The pump is delivered from the factory with paraffin oil with a viscosity close to ISO VG15. In applications where poisonous properties are of less concern, a mineral oil with a viscosity up to ISO VG32 can be used. Other types of normal existing oil can be used, for example an ordinary type of hydraulic oil.

90 20 61 Bearing grease cartridge, Esso Unirex N3
Recommended amount of bearing grease in the bearings (weight in kg).

	3085	3102	3127
Main bearing	0.025	0.025	0.020
Support bearing	0.008	0.012	0.010

NOTE ! Don't inject more grease than required since overheating may otherwise occur.

Special tools

See also the catalogue "Tools for the Flygt service workshop", where you find all the recommended standard and special tools.

Users connected to Flygt's on-line computer system can find the complete service tool list under the dialogue D001, Technical Information. Use the subdialogues D6488 and D6501.

3085

Part No	Denomination	Range of use
216 68 00	Sleeve puller	Rotating seal unit
249 92 03	Impeller puller	LT impellers, curves 620-622
398 71 00	Impeller puller, unit	LT impellers, curves 412-414, 612-614
84 13 62	Impeller puller	} MT impellers NEVACLOG, curves 432-436
82 04 90	Socket head screw	
303 60 00	Impeller puller	
251 35 03	Impeller puller	HT impellers, curves 250-252
251 35 02	Impeller puller	G impellers, curves 242-244
84 13 60	Impeller puller	D impellers, curves 276-284, 470-477
394 69 00	Stator puller	Stator handling, I.D.=130-170 mm
403 90 00	Stator puller unit	Stator handling
463 78 02	Seal tool	Seal type: 397 90 0X, 593 75 0X
479 92 02	Seal tool	Grip ring, seal type: 476 27 0X
426 34 00	Mounting socket	Stationary seal ring fitting, L=110 mm
462 30 00	LP gas set	Heating stator housing
84 20 48	Bearing puller	Support bearing
395 81 05	Tap	Protection pin, bearing puller,
466 97 01	Bearing puller	Main bearing
84 15 45	SKF bearing mounting kit (TMFT 33)	Seal assembly, stationary seal ring

Technical data

3102

Part No	Denomination	Range of use
84 20 48	Puller complete	Support bearing
216 68 00	Sleeve puller	Rotating seal unit
249 92 02	Impeller puller	LT impellers, curves 440-442
295 72 02	Impeller puller	LT impellers, curves 410-412
84 13 62	Impeller puller	MT impellers NEVACLOG, curves 430-435
82 04 90	Socket head screw	
303 60 00	Impeller puller	MT impellers, curves 436-438
344 13 00	Impeller puller	HT impellers, curves 252-254
84 13 62	Impeller puller	D impeller, curve 470
389 25 02	Hexagon screw	F impellers, curves 490-492
394 69 00	Stator puller	Stator handling, I.D.=130-170 mm
398 21 00	Mounting socket	Stationary seal ring, L=185 mm
457 89 00	Seal tool	Grip ring
395 81 05	Tap	Protection pin, bearing puller
466 97 01	Bearing puller	Main bearing, removal / fitting
84 15 45	SKF bearing mounting kit (TMFT 33)	Seal assembly, stationary seal ring
462 30 00	LP gas set	Heating stator housing

Technical data

3127

Part No	Denomination	Range of use
84 20 48	Puller complete	Support bearing
216 68 00	Sleeve puller	Rotating seal unit
249 92 04	Impeller puller	LL, LT, MT impellers, curves 410-412, 441-442, 430-436
303 58 00	Hexagon screw	HD impellers, curves 466-468
309 39 00	Impeller puller	HT impellers, curves 250, 461-467
84 13 62	Impeller puller	HT impellers, curves 254-259 and NEVACLOG 480-485
82 06 60	Socket head screw	
84 13 62	Impeller puller	D impellers, curves 275-277, 470-471
394 69 00	Stator puller	Stator handling, I.D.=130-170 mm
396 70 00	Hexagon screw	F impellers, PL propellers, curves 490-492, 495-496
400 39 00	Mounting socket, seals	L=160/185 mm
436 97 00	Seal tool	Grip ring
438 58 00	Hexagon screw	F impellers
395 81 05	Tap	Protection pin, bearing puller
466 98 01	Bearing puller	Main bearing
84 15 45	SKF bearing mounting kit (TMFT 33)	Seal assembly, stationary seal ring
462 30 00	LP gas set	Heating stator housing

Impeller code / curve code, see the pump data plate

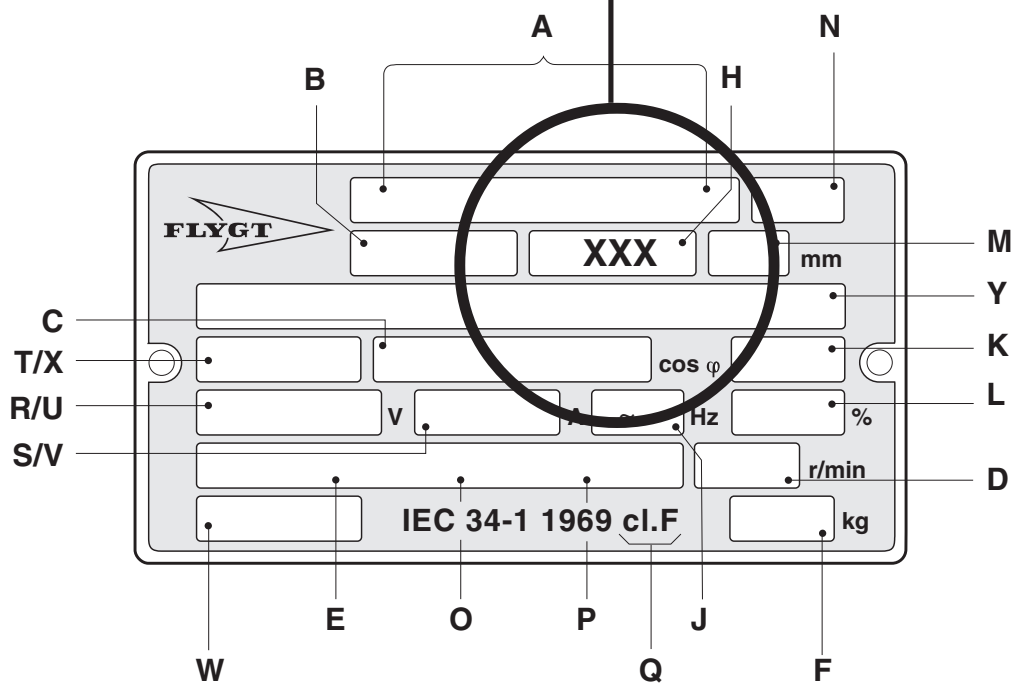

Electrical connections

Electrical connections



NOTE for Ex version:

All work on the explosion-proof motor section must be done by personnel approved by Flygt.

Connect the stator leads and the motor cable as shown in the wiring diagrams.

NOTE! For safety reasons, the earth conductor should be approx. 50 mm (2.0") longer than the phase conductors. If the motor cable is jerked loose by mistake, the earth conductor should be the last conductor to come loose from its terminal. This applies to both ends of the cable.

Monitoring equipment

Thermal switches are incorporated into the stator. The thermal switches may be used for voltages up to 250 V, rated current 10 A ($\cos \varphi = 1$) / 6.3 A ($\cos \varphi = 0.6$). Flygt recommends that they be connected to 24 V over separate fuses to protect the other automatic equipment.

A plate in the junction box shows whether the pump is equipped with optional sensors.

CLS-30 is a leakage sensor for sensing water in the oil housing and initiates an alarm when the oil contains 30% water. Oil change is recommended after the alarm. If the sensor initiates an alarm soon after the oil has been changed, contact your nearest Flygt representative.

The CLS-30 sensor is installed in the bearing housing and goes down into the oil housing. The sensor is not applicable to Ex-approved pumps.

The **FLS** sensor consists of a small float switch for sensing water in the stator housing. Its design makes it suitable for pumps in vertical installations.

The FLS sensor is installed in the bottom of the stator housing.

The two sensors, CLS-30 and FLS, can be used in the same pump. They are connected in parallel. Follow the instructions for monitoring equipment.

Check:

- signals and tripping function.
- that relays, lamps, fuses and connections are intact.

Replace defective equipment.

Stator lead colours

U1/U5	Red
V1/V5	Brown
W1/W5	Yellow
U2/U6	Green
V2/V6	Blue
W2/W6	Black

Flygt SUBCAB® cable

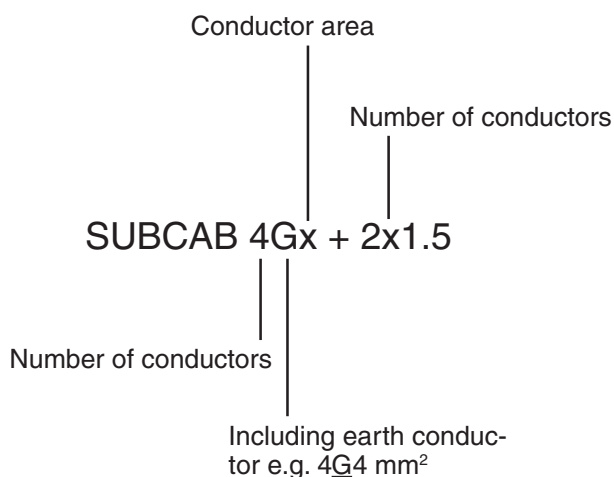

Electrical connections

3-phase, direct on-line starting

	Conductors	Connection starter
SUBCAB® 4Gx	brown	L1
	blue	L2
	black	L3
	yellow/green	earth
SUBCAB 4Gx+2x1.5	brown	L1
	blue	L2
	black	L3
	yellow/green	earth
	black	T1*
	black	T1*

* Terminal for connection of thermal switches in the motor and monitoring equipment.
 ** GC = Ground Check

SUBCAB is a registered trademark of ITT Flygt AB for electric cables.

	Conductors	Connection starter
For Canada/USA SUBCAB xAWG/4	red	L1
	white	L2
	black	L3
	yellow/green	earth
SUBCAB xAWG/7	red	L1
	white	L2
	black	L3
	yellow	GC**
	yellow/green	earth
	orange	T1*
	blue	T2*

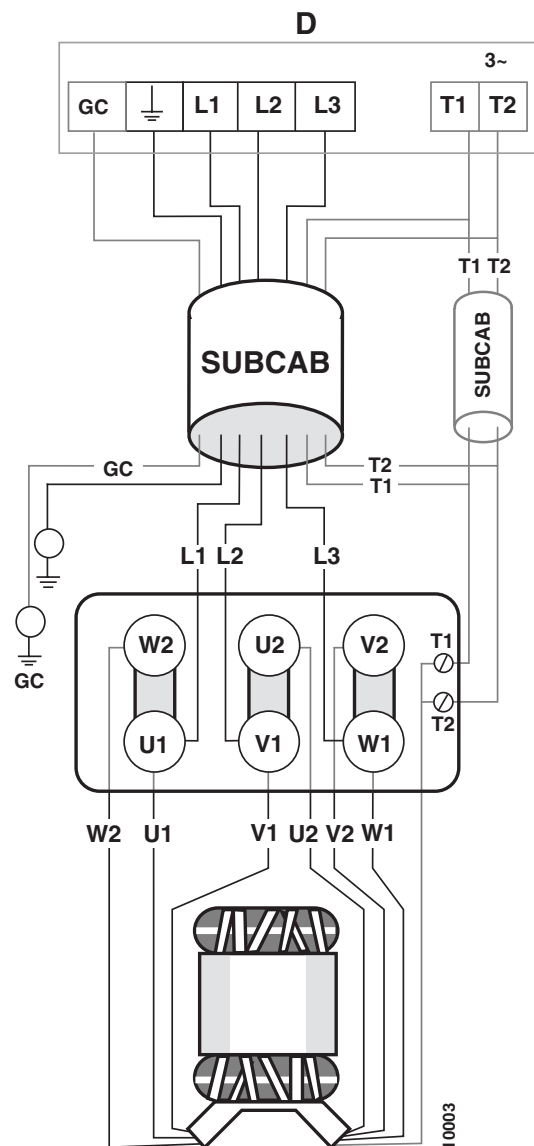
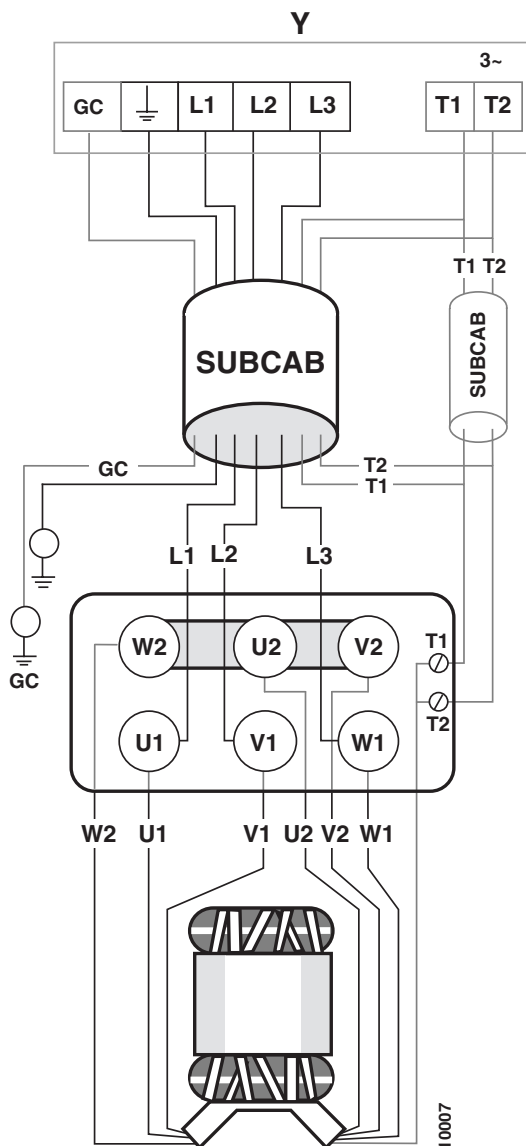

Electrical connections

3-phase, star-delta starting

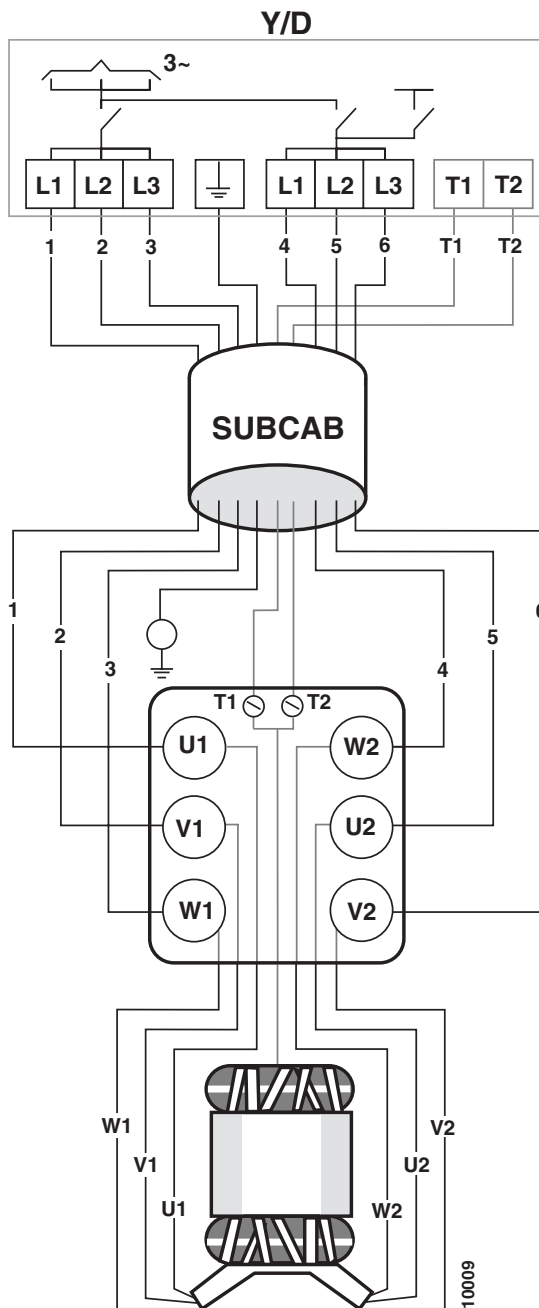

Conductors	Connection starter
SUBCAB 7Gx	
black 1	L1
black 2	L2
black 3	L3
black 4	L1
black 5	L2
black 6	L3
yellow/green	earth

SUBCAB 7Gx+2x1.5	
black 1	L1
black 2	L2
black 3	L3
black 4	L1
black 5	L2
black 6	L3
black T1	T1*
black T2	T2*
yellow/green	earth

* Terminal for connection of thermal switches in the motor and monitoring equipment.

Electrical connections

Single phase

	Conductors	Connection starter
SUBCAB 4Gx	brown black blue yellow/green	1 2 3 earth
SUBCAB 4Gx+2x1.5	brown black blue yellow/green black black	1 2 3 earth T1* T2*

For Canada/USA SUBCAB xAWG/4

	Conductors	Connection starter
SUBCAB xAWG/4	red black white yellow/green	1 2 3 earth
SUBCAB xAWG/7	red black white yellow yellow/green orange blue	1 2 3 GC** earth T1* T2*

* Terminal for connection of thermal switches in the motor and monitoring equipment.
** GC = Ground Check

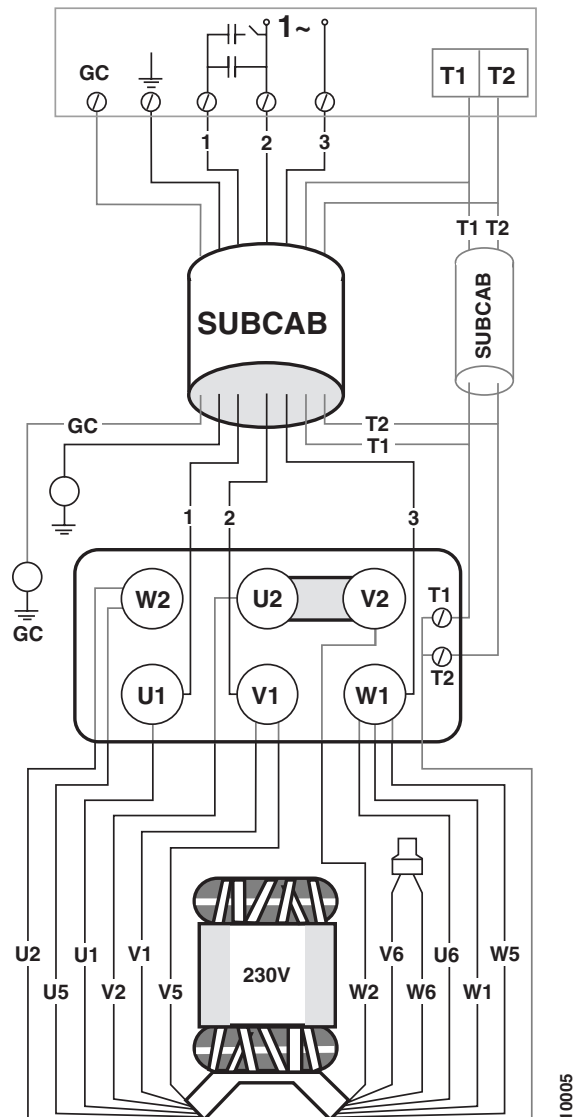
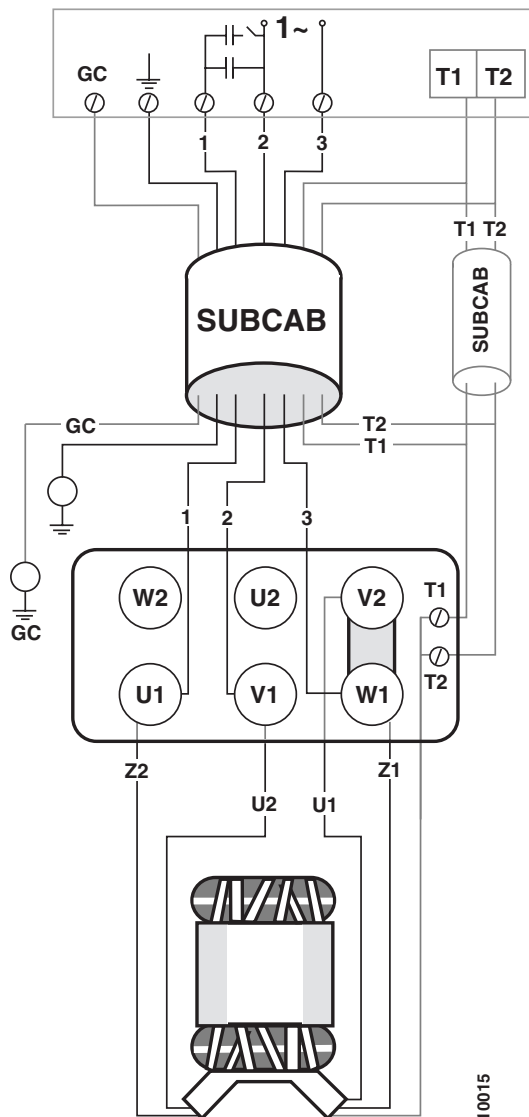



Notes

A series of horizontal dotted lines for writing notes.

Notes

A series of horizontal dotted lines for writing notes.



Notes

A series of horizontal dotted lines for writing notes.



7



8

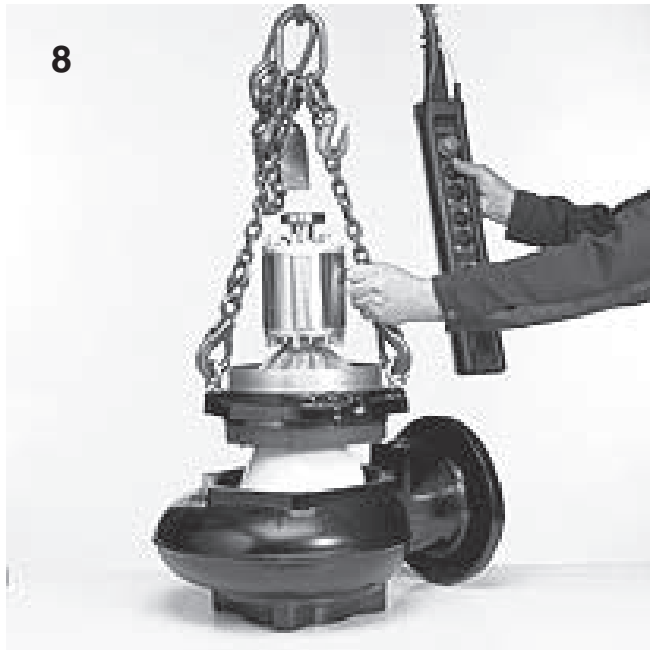

9
3085

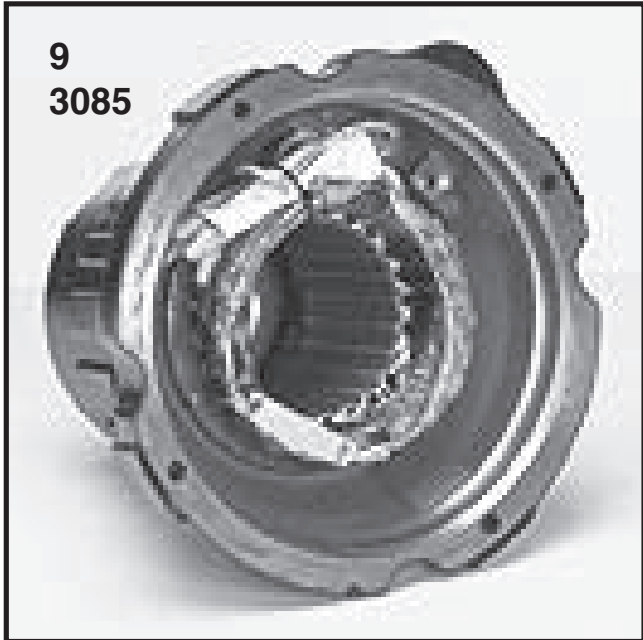

10
3085

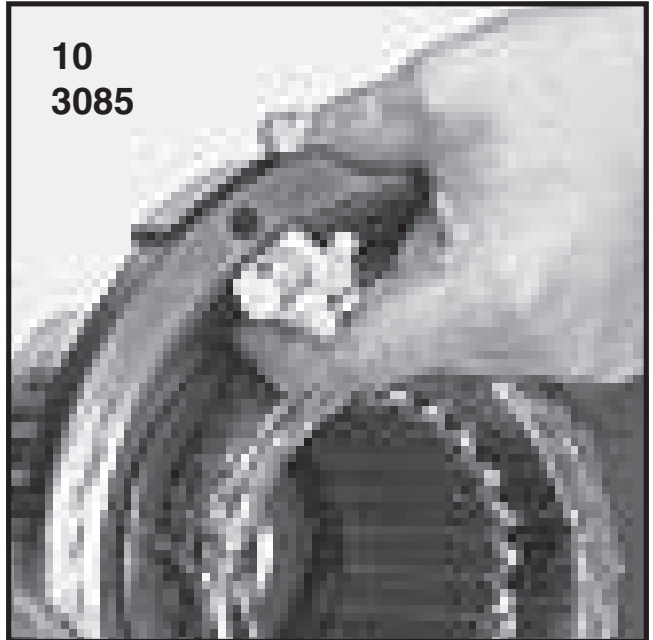

11
3085



12
3085

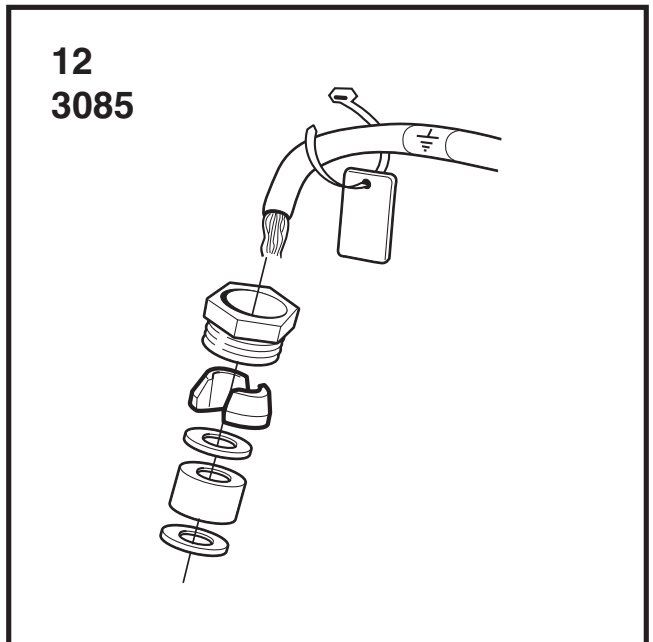

13

**3102
3127**



14

**3102
3127**



15

**3102
3127**



16 | 3102, 3127



17

**3102, 3127
Ø 12-20 mm
(0.47"-0.79")**

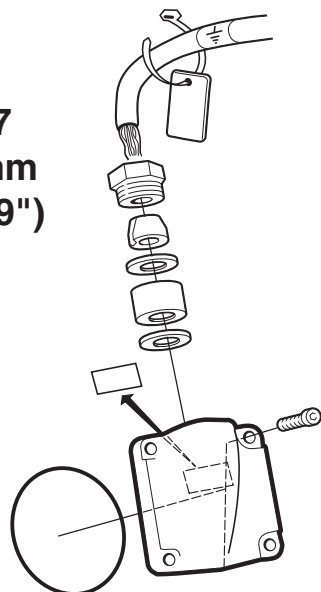

18 | 3102, 3127

**Ø 20-32 mm
(0.79"-1.26")**

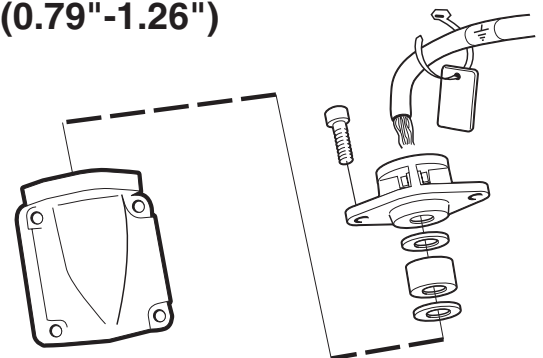

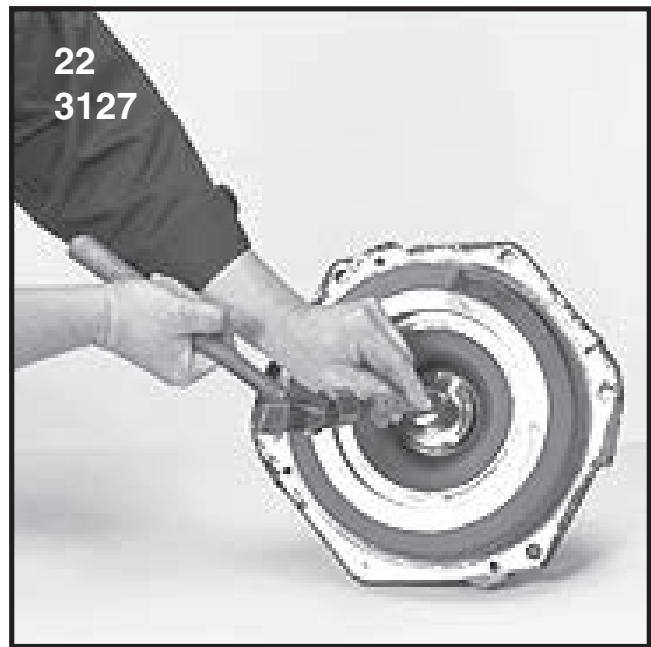
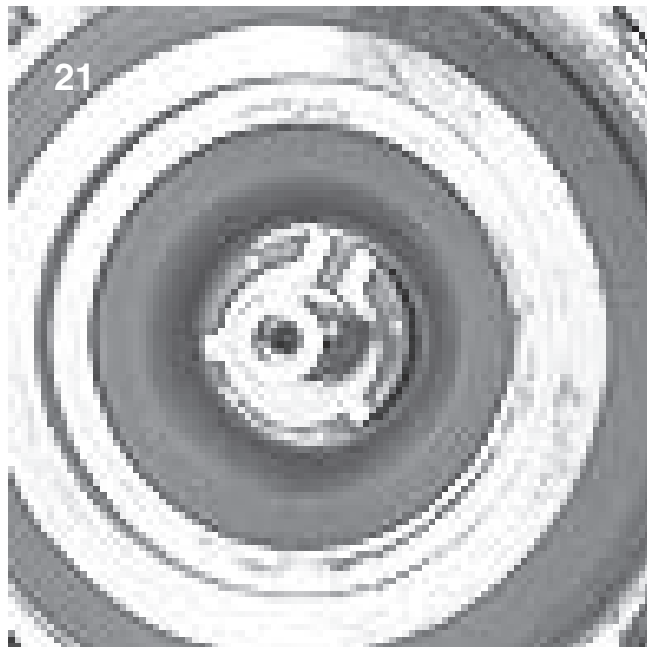



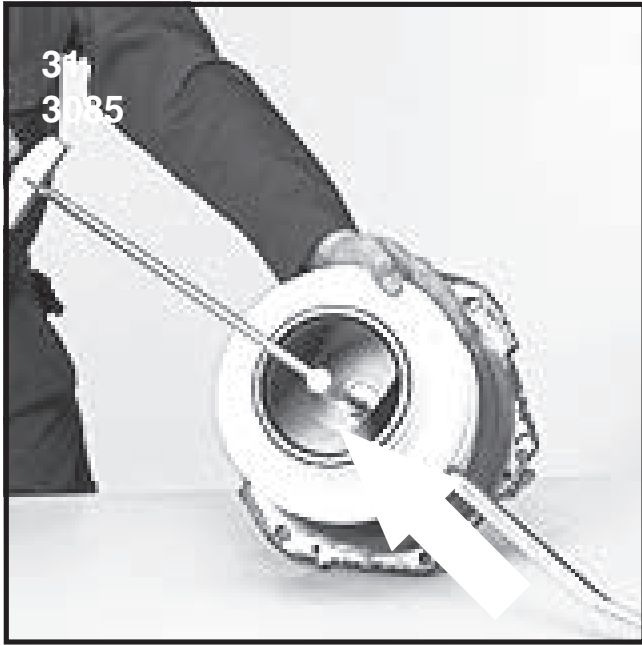

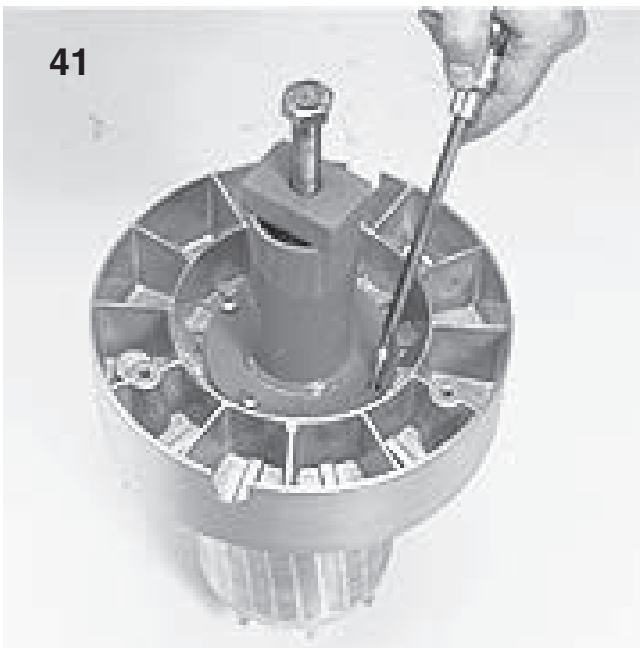
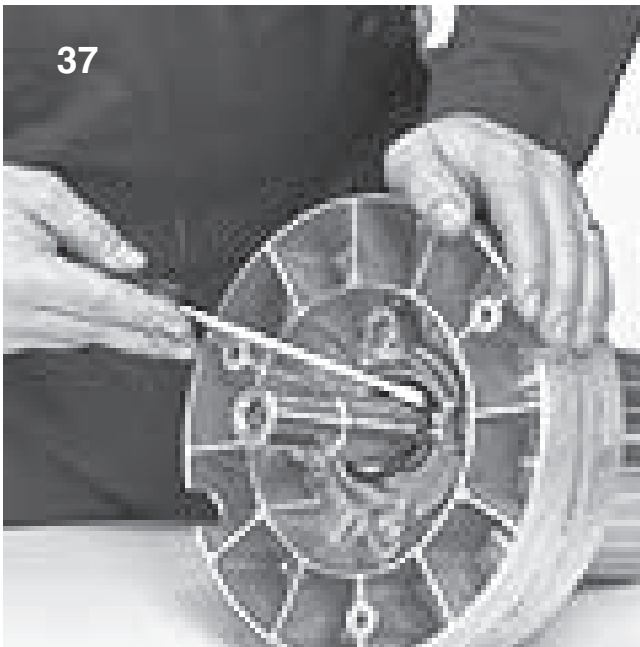

43



44



45



46



47



48



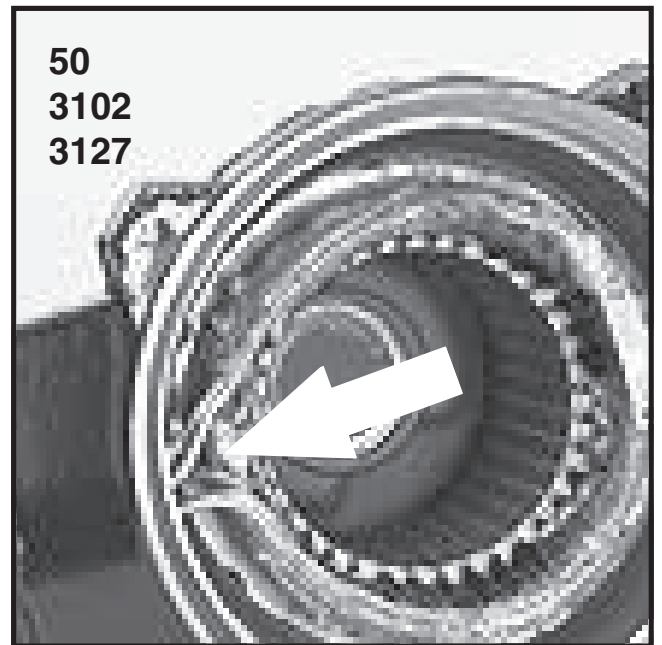



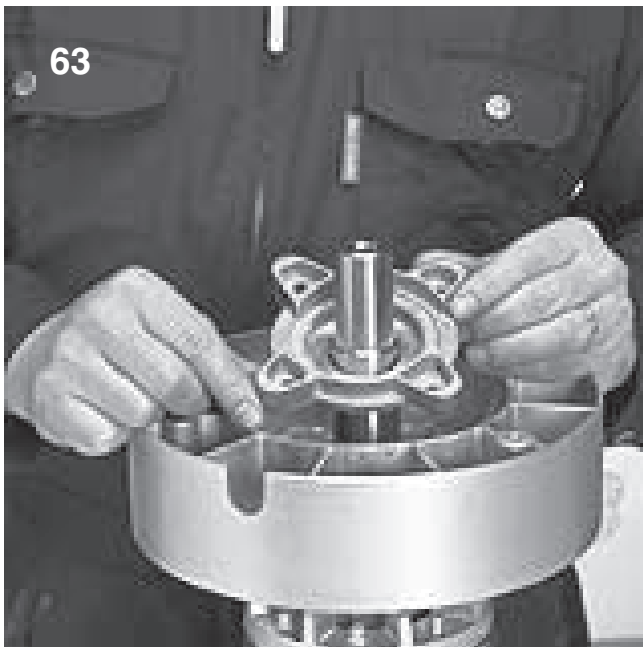
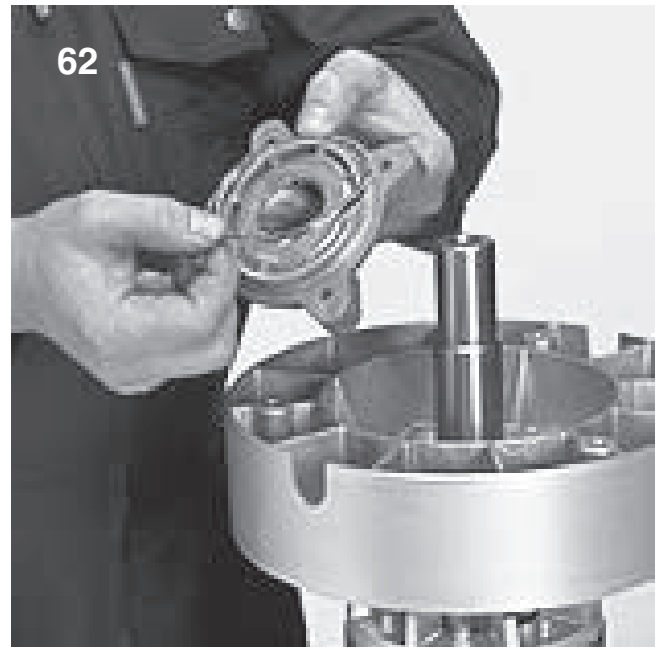

3085 outer / inner

PART NUMBER
593 75 00
593 75 01
593 75 02

601 26 00

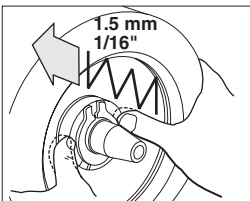
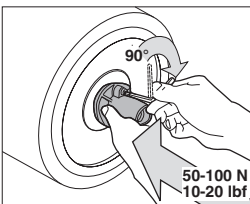
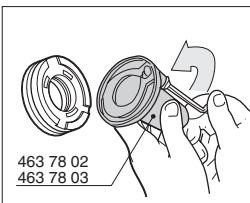
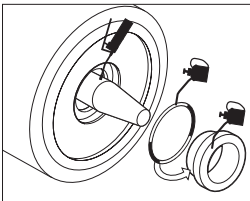
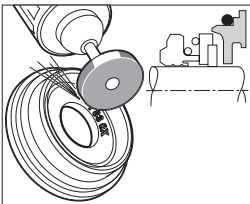
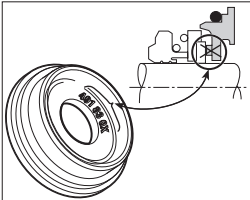
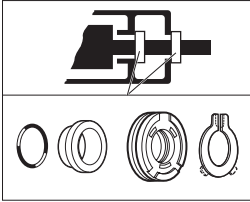
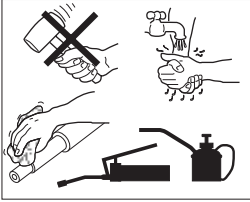

3085 outer, optional

PART NUMBER
476 27 05
476 27 08

557 94 00

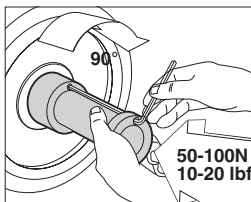
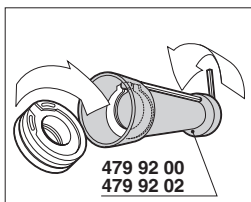
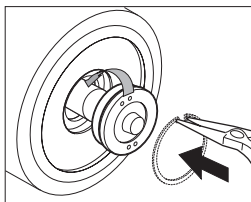
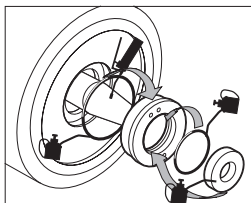
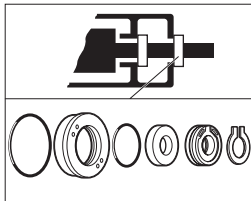
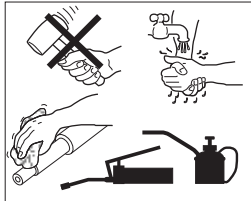

3085 outer, optional

PART NUMBER
476 27 04
476 27 06
476 27 07

557 95 00

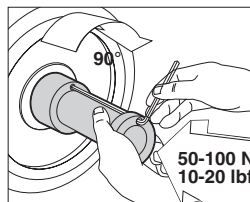
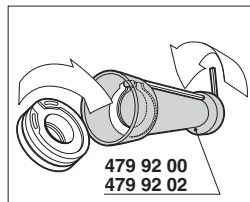
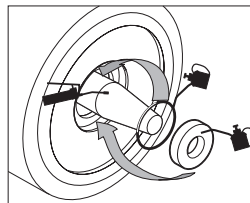
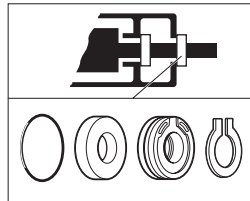
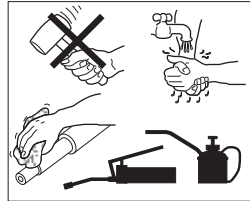

3102 outer

PART NUMBER
592 01 00
592 01 02
592 01 04

601 22 00

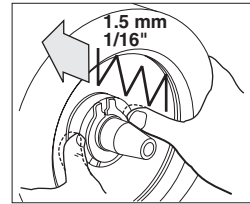
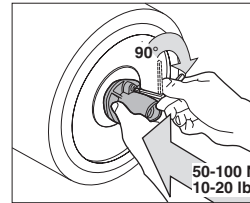
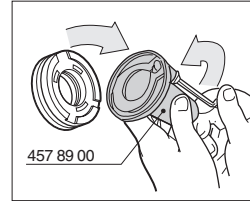
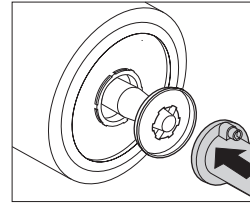
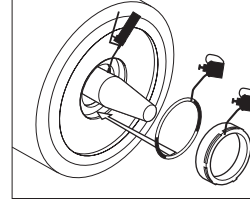
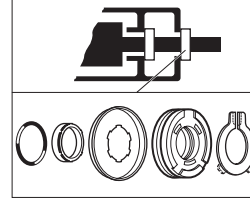
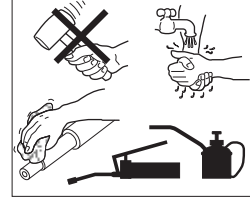

3102 inner

3127 inner

3127 outer / inner 3127 outer, optional

PART NUMBER
592 01 01
592 01 03

601 23 00

PART NUMBER
593 70 01

601 25 00

PART NUMBER
593 70 00

601 24 00

PART NUMBER
549 07 01
549 07 02

577 47 00

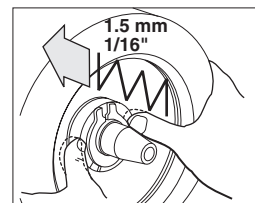
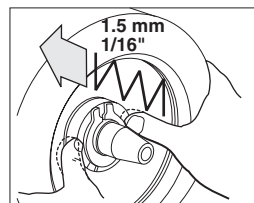
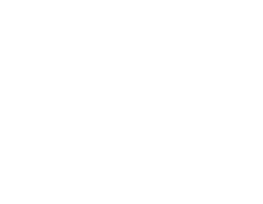
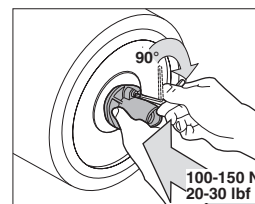
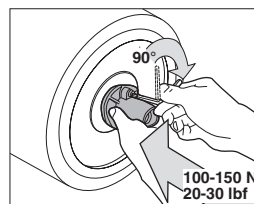
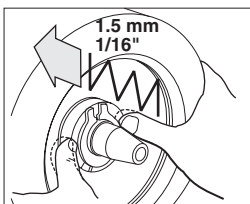
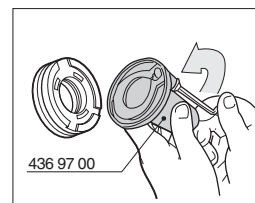
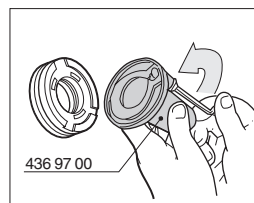
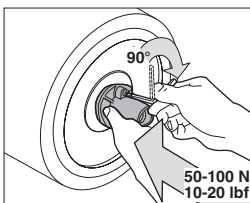
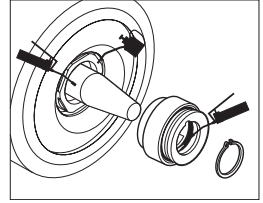
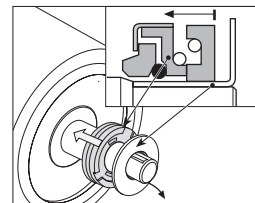
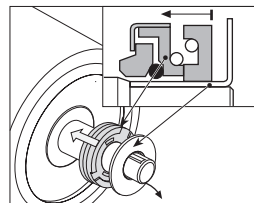
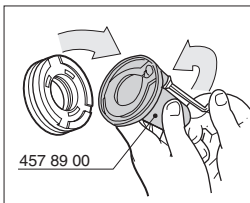
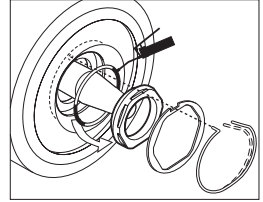
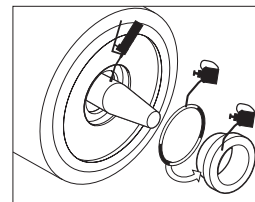
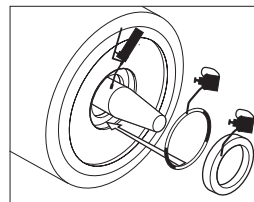
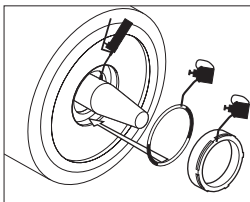
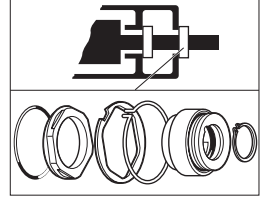
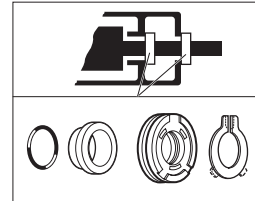
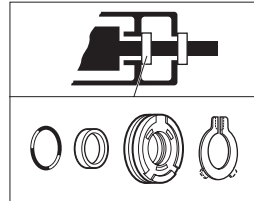
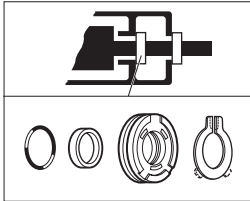
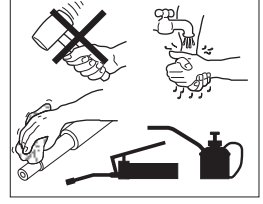
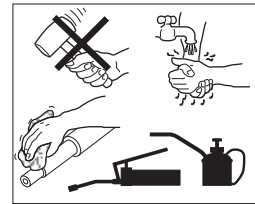
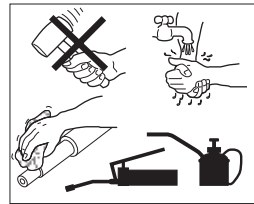
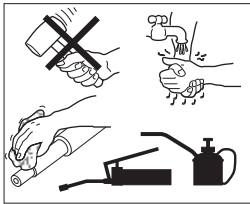

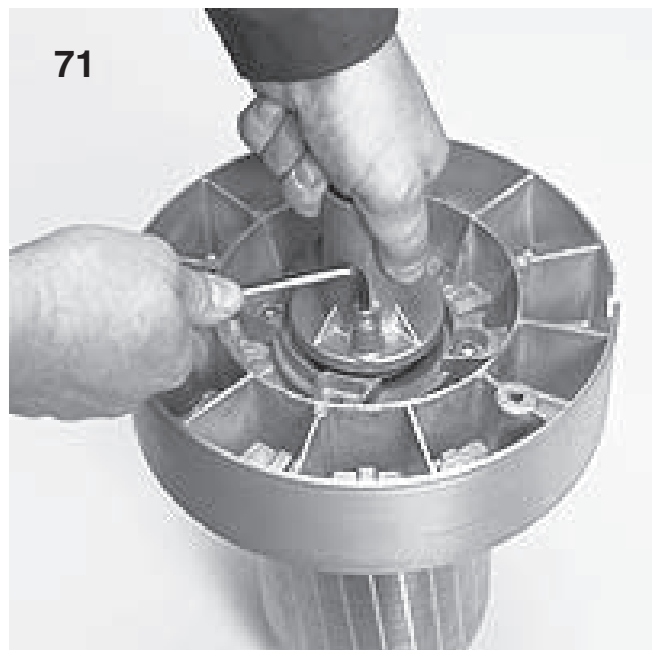
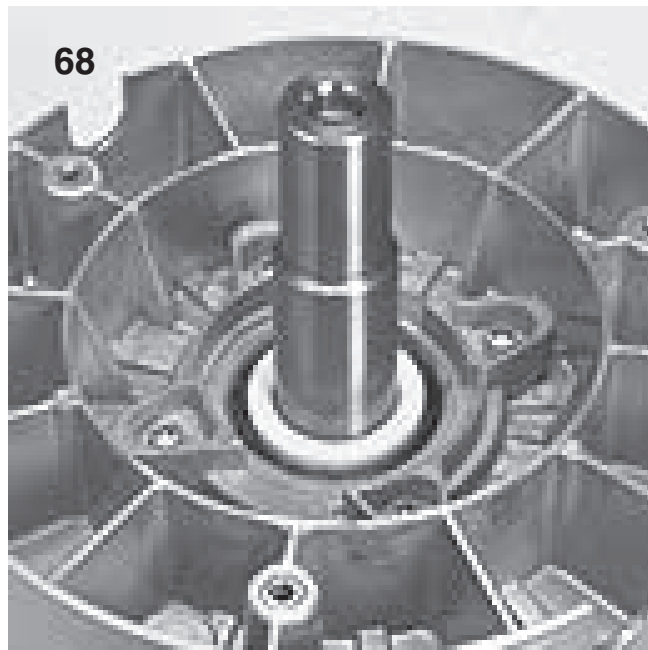
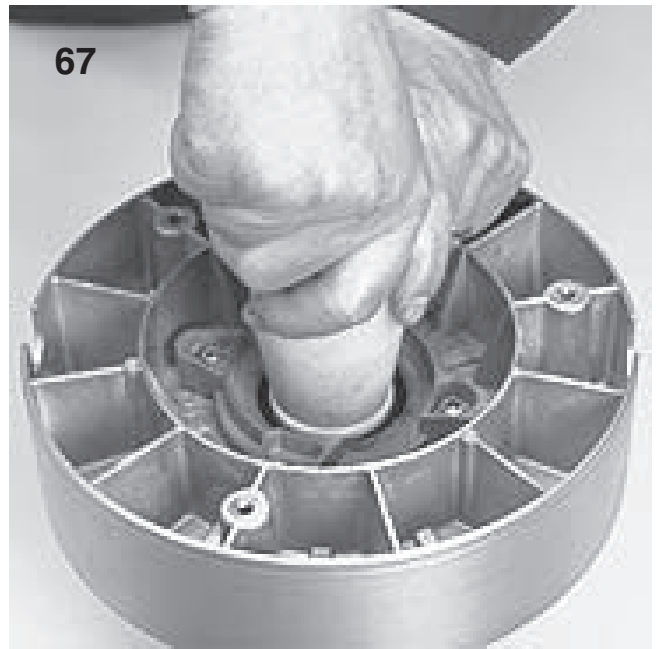
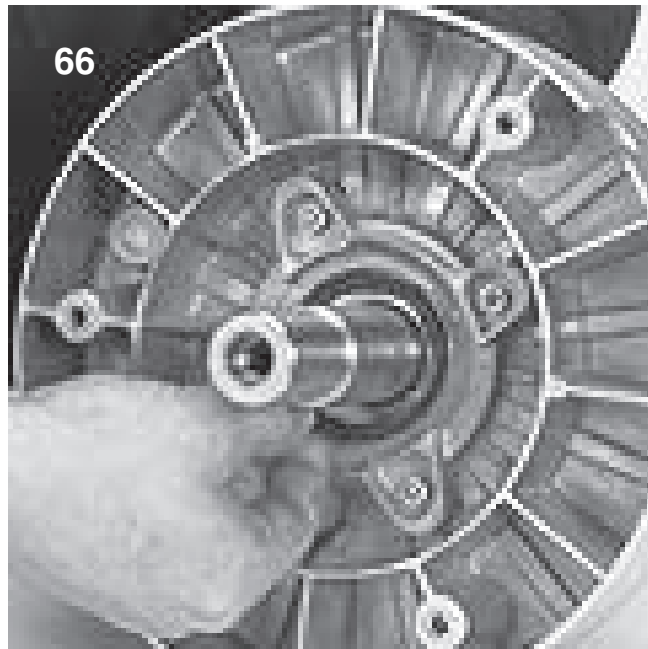

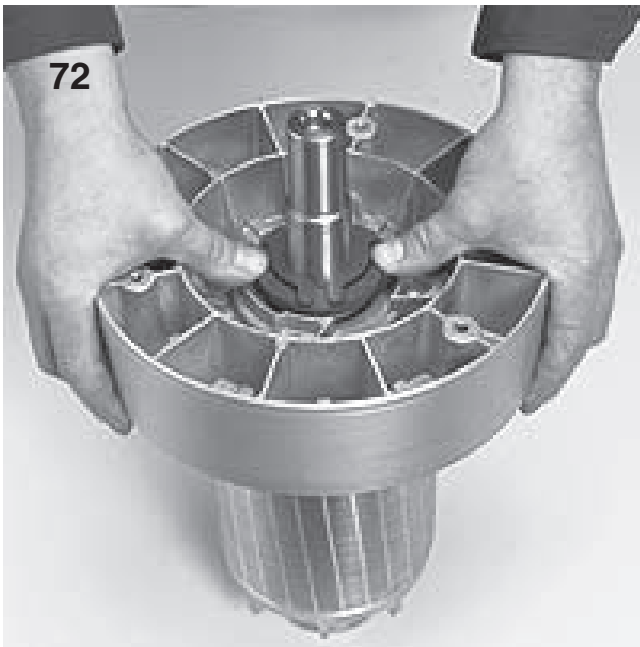



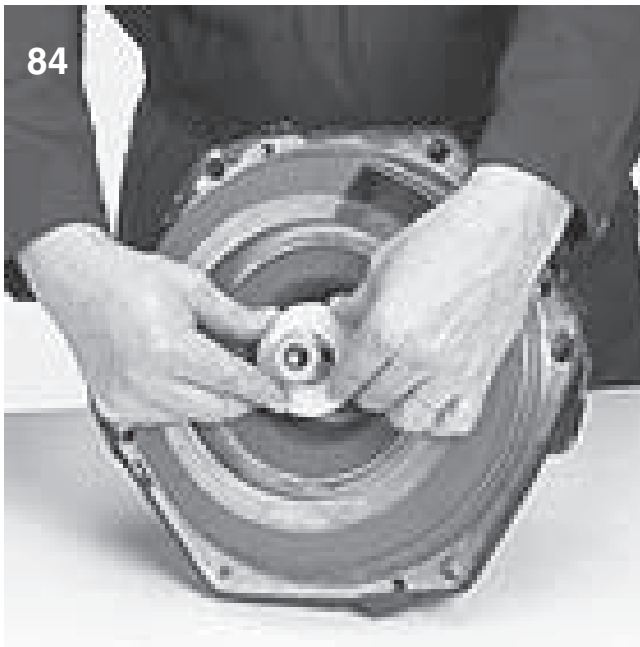

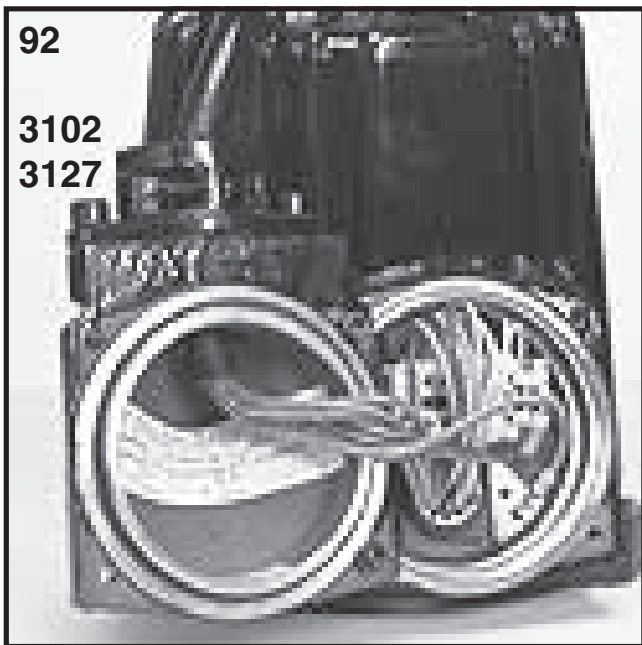
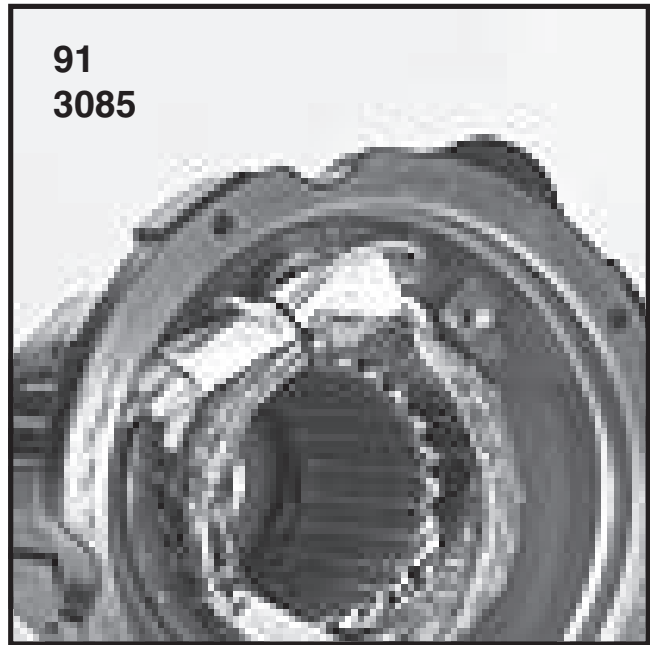
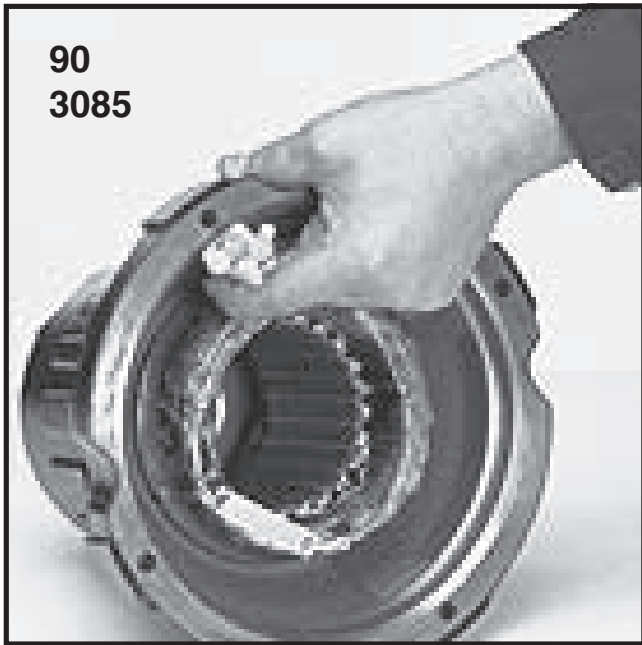

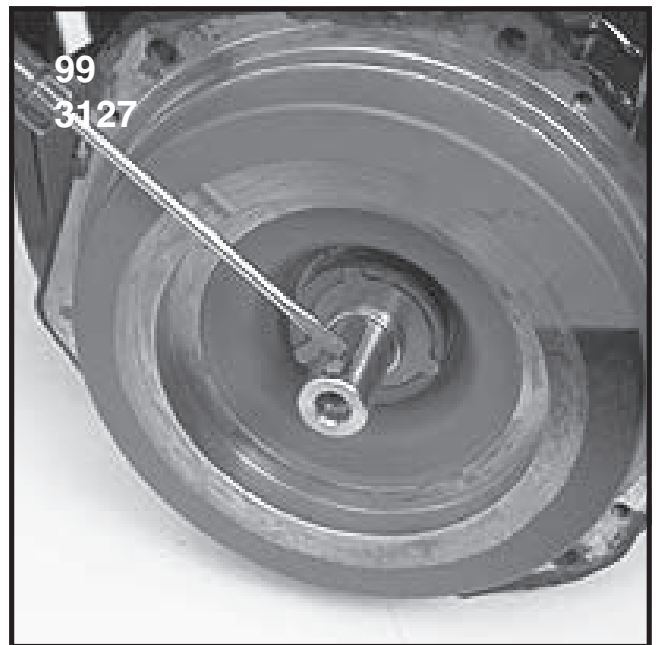
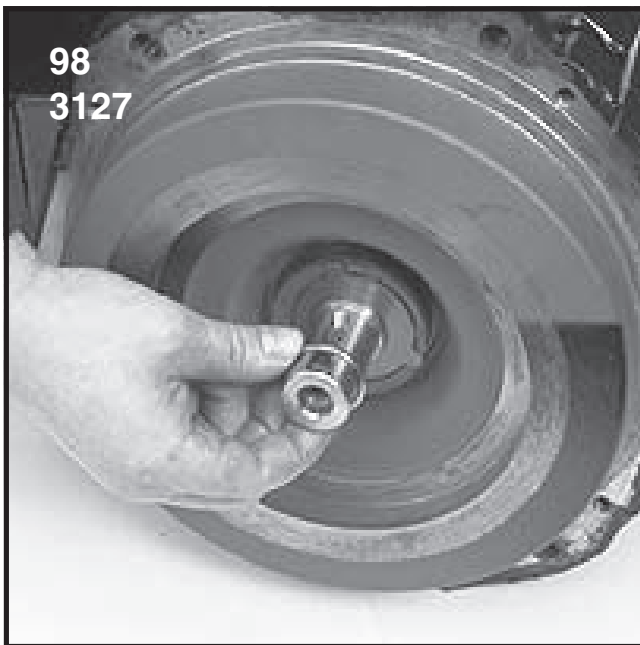

102



103



104

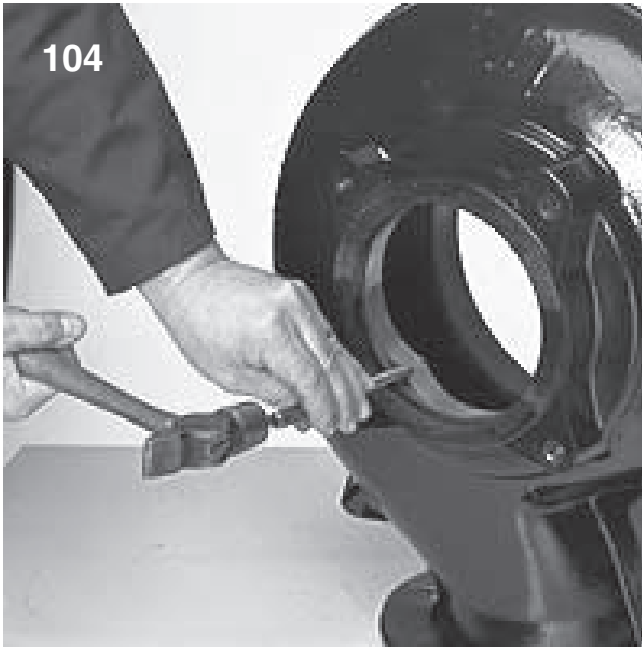

105

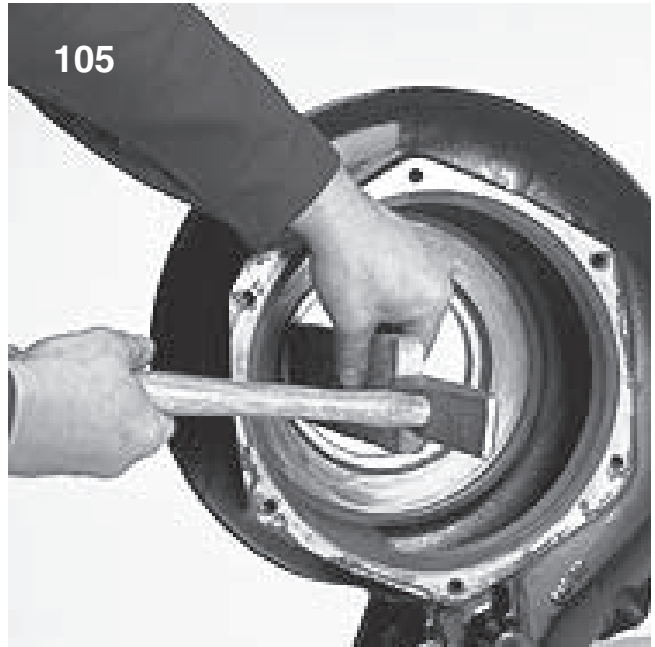

106



107



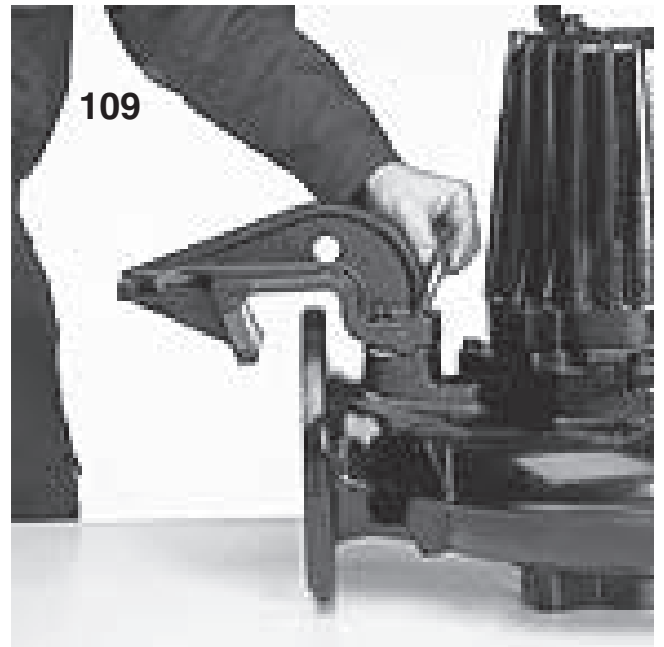
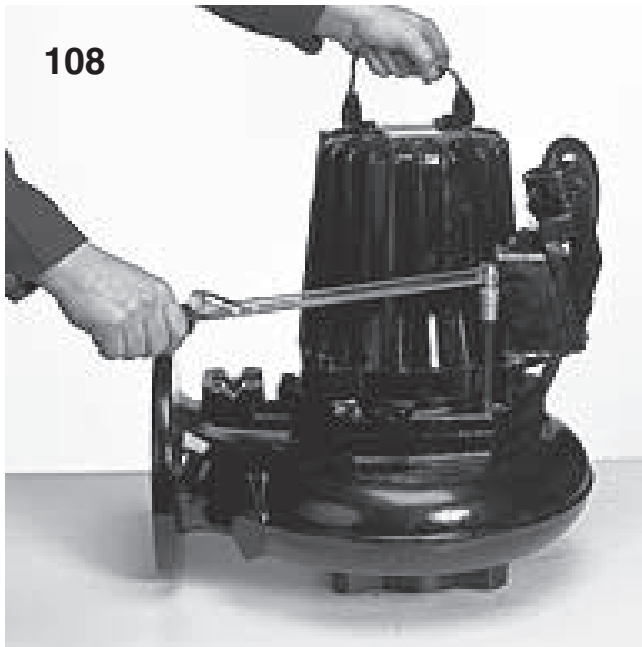

114

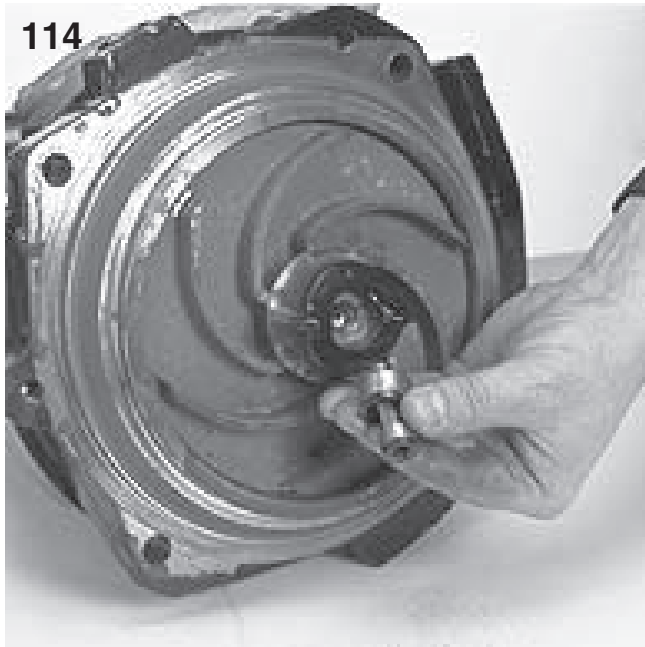

115

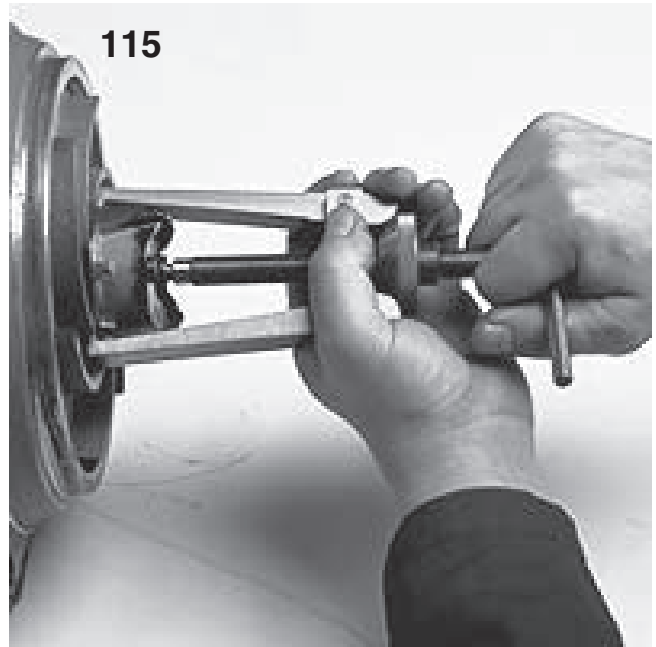

116



117

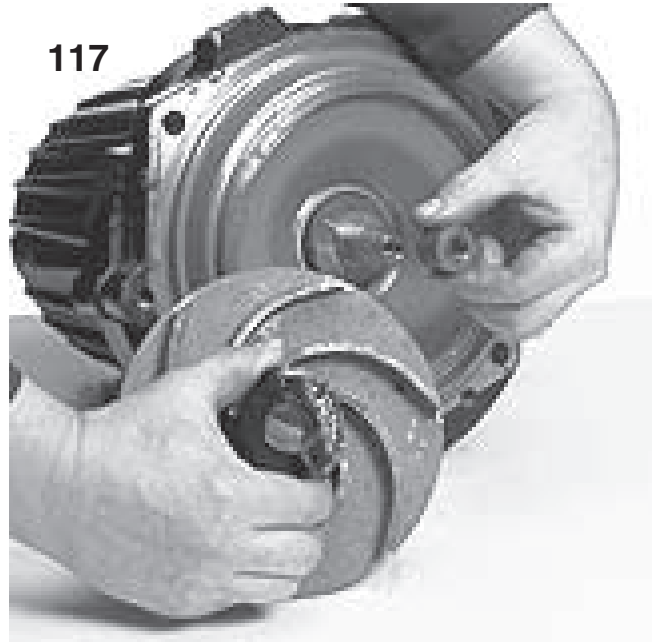

118

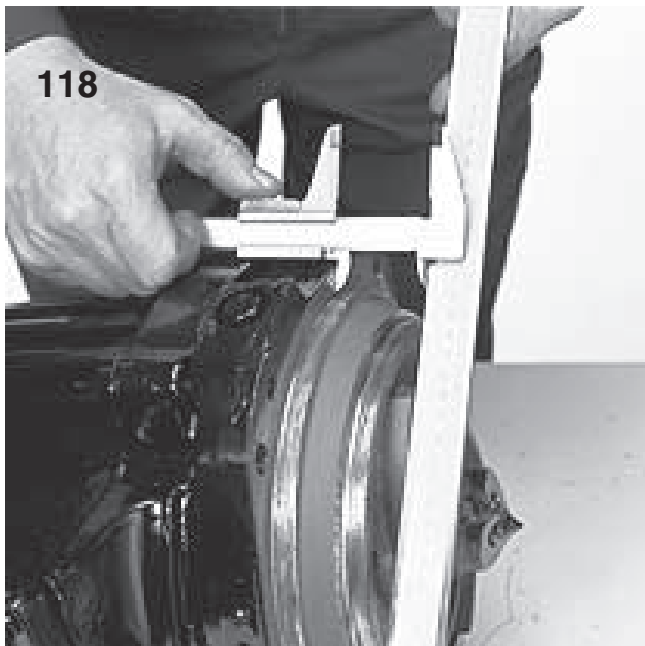

119



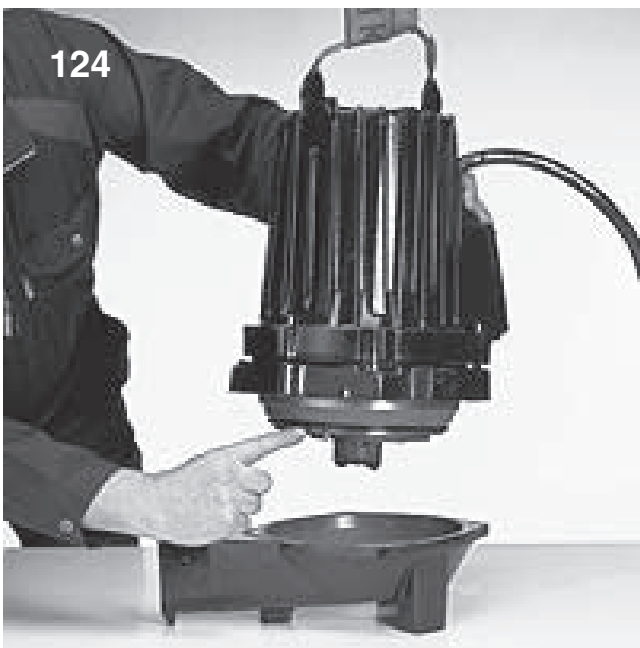
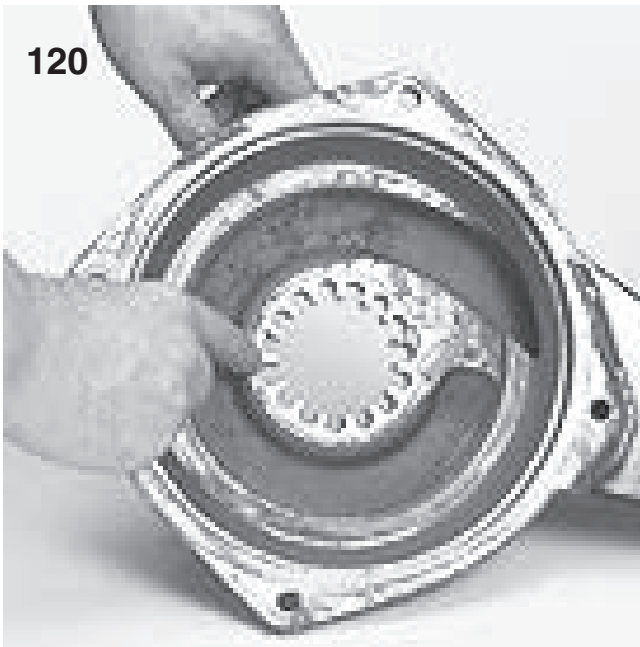



132



133



134

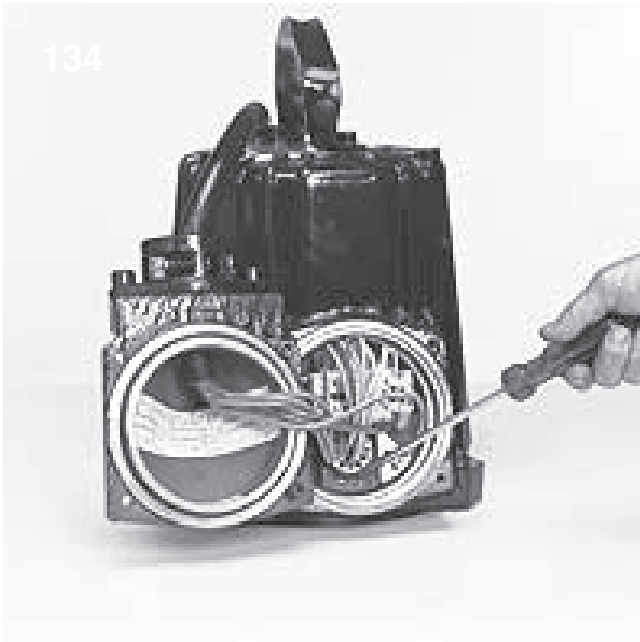

135



136



137





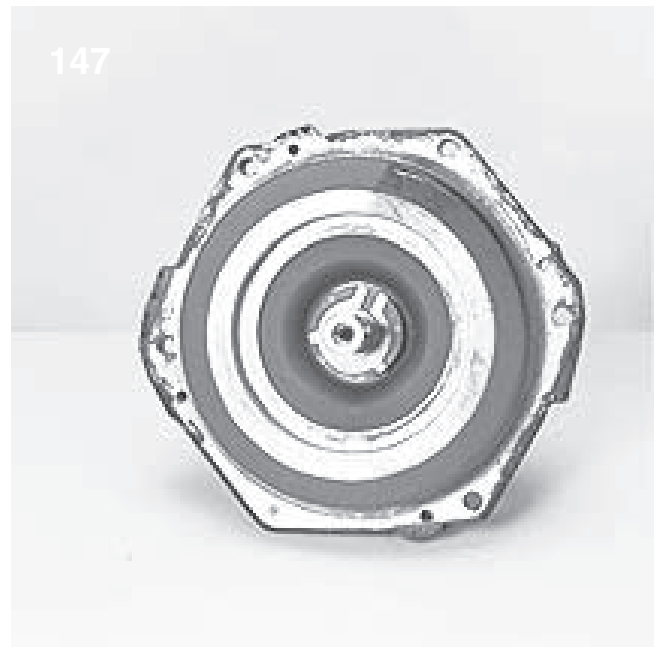



Dismantling

Before starting the work on the pump, make sure that all tools are at hand and that O-rings and any other part that are to be replaced are set out. Clean all parts carefully, especially the O-ring seats. Lubricate all screws that have been removed before refitting them. Make sure that the pump is isolated from the power supply before starting work.

If the pump is specially approved, first read through the section "Specially approved pumps".

1. C 3127. (The pictures below also apply to C 3085 and C 3102).
2. Suspend or support the pump horizontally. Place a suitable vessel under the oil casing. Remove the "Oil in" screw.

Warning! If the seal leaks, the oil casing may be under pressure. Hold a rag over the oil plug to prevent splatter.

- 3-4. Remove the "Oil out" screw and empty the pump oil casing.
- 5-6. Unbolt and lift the stator housing from the oil housing.
- 7-8. Release and lift the rotor assembly with the oil housing and the impeller from the pump housing. Use two M10 eyebolts.

3085 Cable connection.

- 9-10. Remove the insulating hose from the stator leads. Disconnect the motor cable from the stator leads by cutting the leads close to the closed end splice.
11. Undo the earth screw and the cable entry and pull the motor cable out of the stator housing. Inspect the cable for damage, specially close to the cable entry.
12. Cable entry.

3102 and 3127 Junction box.

13. Stator housing.
- 14-15. Open the junction box cover and disconnect the motor cable and the stator leads from the terminal board.
16. Pull out the stator leads through the cable lead-through / hole into the stator housing. Undo the cable entry and pull the motor cable out of the cover. Inspect the cable in order to detect damage, specially close to the cable entry.
- 17-18. Cable entry.

Dismantling the impeller and outer seal unit.

19. Undo the impeller screw.
20. Pull off the impeller with the aid of a puller (see special tool list).
21. Outer face seal.
22. Remove the key with a hammer and chisel (only 3127).
23. Remove the spacer ring (only 3127).
- 24-25. Remove the grip ring with seal tool (see special tool list).
26. Grip ring.
- 27-28. Remove the outer rotating seal ring with the seal remover tool.
- 29-30. Remove the outer stationary seal ring with the seal remover tool.
31. For 3085 it is possible to replace both the outer and the inner seal unit without dismantle the oil housing. Remove the retaining ring.

Dismantling the oil casing and inner seal unit.

32. Undo the three socket hexagon screws which hold the oil casing together.
33. Lift off the rotor unit together with the bearing holder.
34. Dismantle the inner face seal in the same manner as for the outer face seal. Dismantle the grip ring with the seal tool.
35. Remove the rotating seal ring.
36. Dismantle the stationary seal ring with two screwdrivers.

Exploded view

3085.092

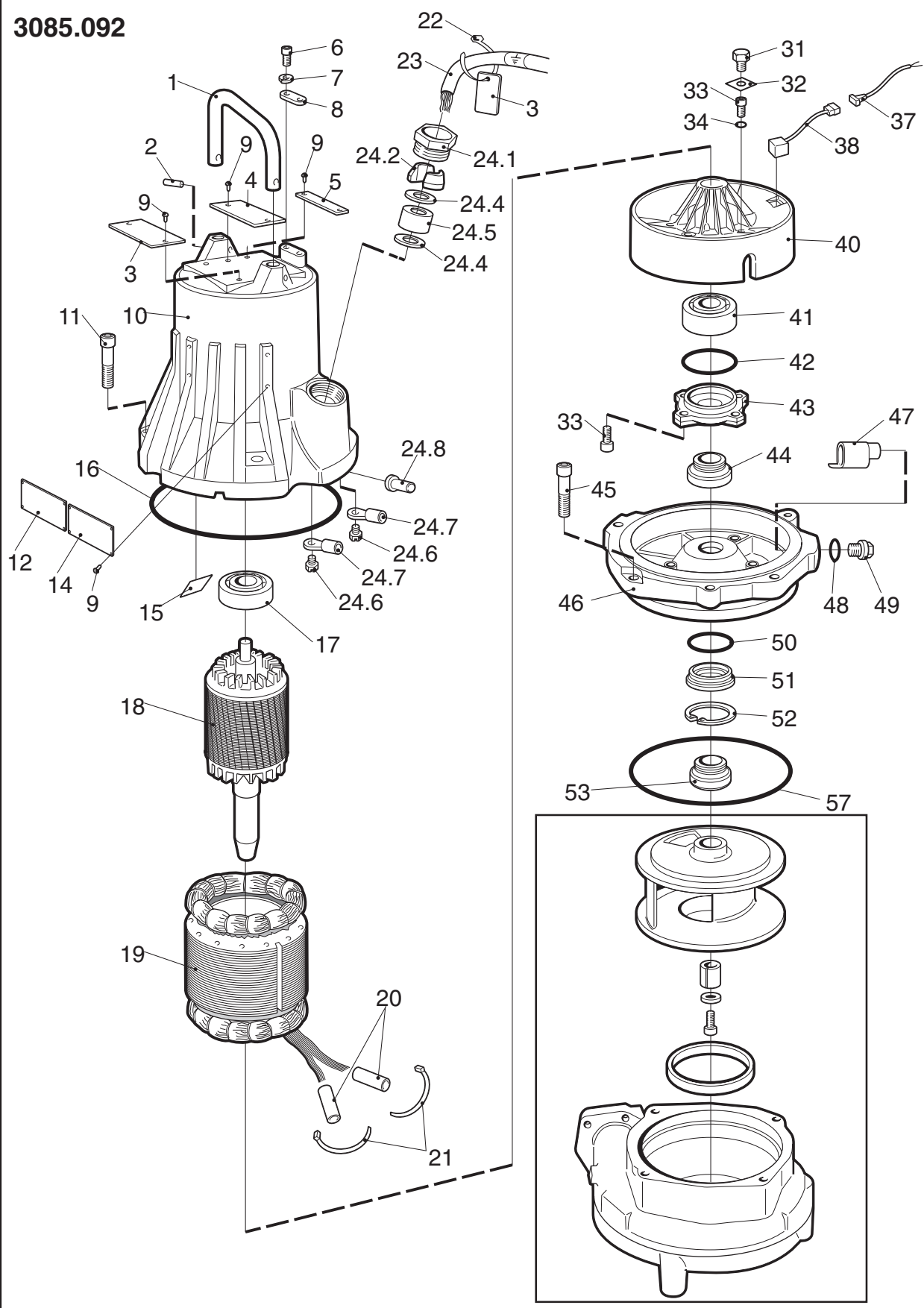

Exploded view

3085.172

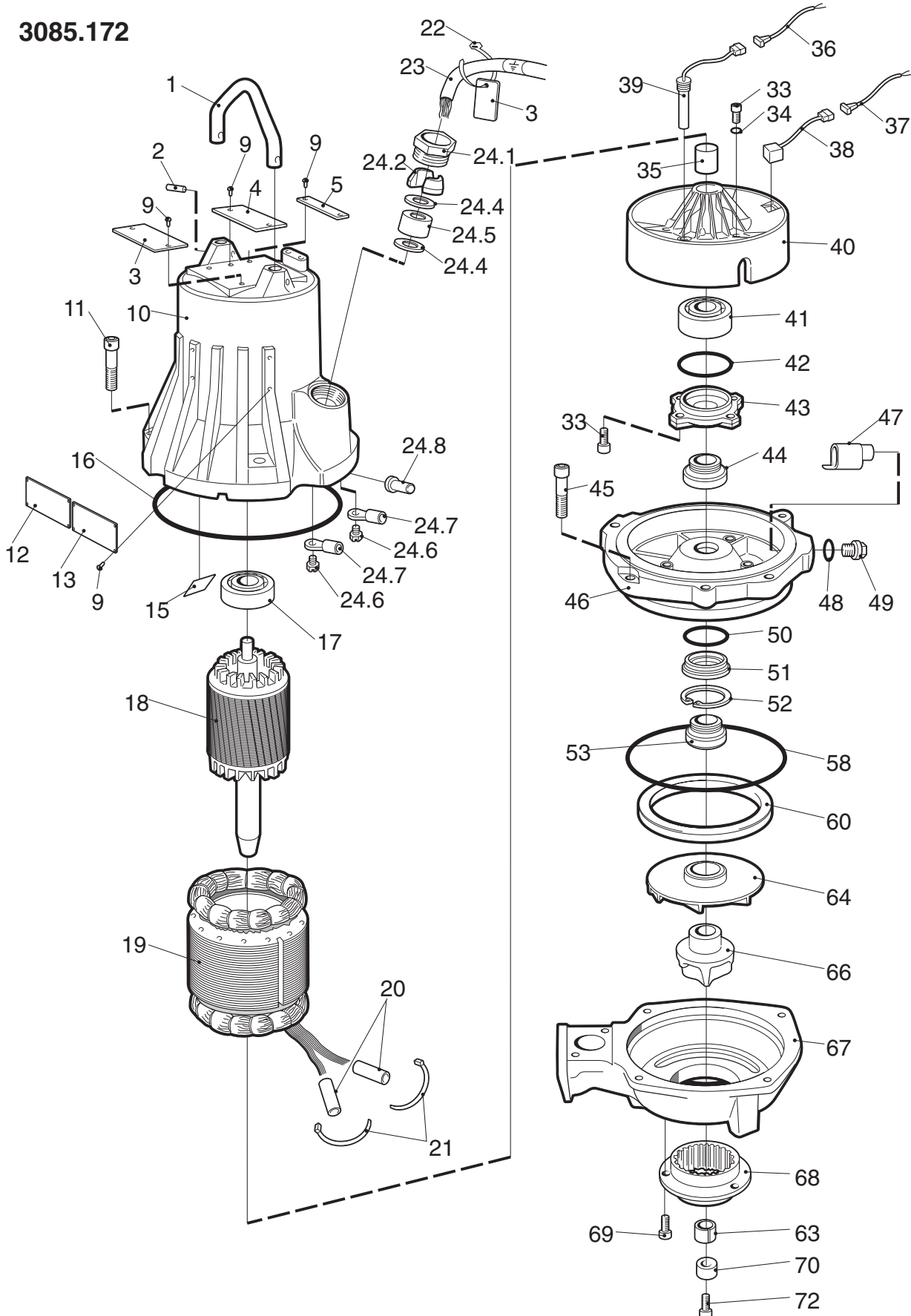

Exploded view

3085.182

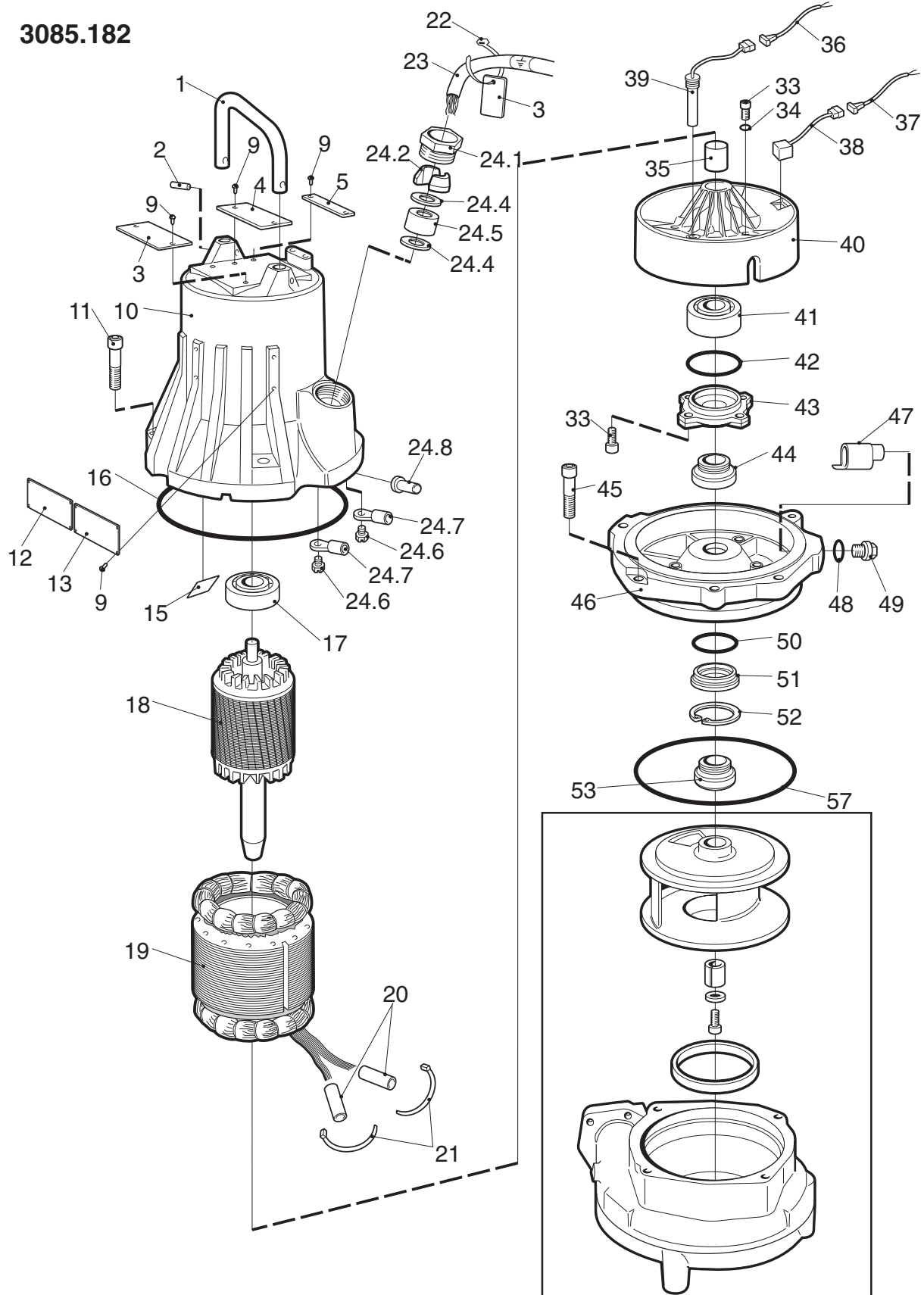

37. Remove the O-ring.
38. Undo the four inner hexagon screws.
39. Remove the bearing cover.

Dismantling the upper and lower bearings.

- 40-41. Insert a protection pin (Tap) in the hole in the end of the shaft in order to protect the thread and fit the bearing puller tool with the screws for the bearing cover.
- 42-43. Pull off the bearing holder with a combination wrench (24 mm across flats) and an adjustable wrench.
44. Remove the distance sleeve from the hydraulic end of the shaft.
45. Knock out the bearing from the bearing holder with a suitable mandril.
46. Pull off the upper bearing with a puller.
47. Remove the lifting handle and replace with two M10 eyebolts. Lift up the stator using the eyebolts and place a suitable protecting device under the stator. Heat the stator housing **quickly** in order to let the stator loosen. Use LP gas set. When the stator has released and dropped down, extinguish the flames and lift the stator housing.

Assembly

Assembling the stator with stator housing, upper and lower bearings.

- 48-49. Heat the stator housing to about 150°C (302°F), then quickly lower the stator into the stator housing until it bottoms. Use Stator lifting device. Note! The stator must be oriented in such a manner in the stator housing that the leads reach up to the motor cable connection or terminal board.
50. Pull the stator leads through the cable lead-through / hole from the stator housing into the terminal board (3102, 3127). Connect the leads as shown in the charts in the chapter "Electrical connections".
51. Heat the upper bearing to about 100°C (212°F)(max 120°C, 248°F) in an oven, in oil or with a heating dowel. Place the heated bearing on a smooth surface and insert the end of the shaft into the bearing. Allow the bearing to cool.
52. Apply bearing grease. See lubricants, Technical data.
53. Fit the distance sleeve onto the shaft.
54. Lubricate the shaft with oil in order to allow the bearing to slide more easily into place.
- 55-56. Lubricate the main bearing and fit the bearing into its holder.
57. Press the bearing into place. Use the bearing puller tool plus a rubber mallet.
Alternatives:
 - Heat the bearing holder
 - Use a press.
58. Fit the bearing holder onto the shaft unit.
59. Fix the bearing puller.
60. Mount the screw + washer that fits the threaded hole for the impeller.
61. Press the bearing and bearing holder onto the shaft. Use a combination wrench (18 mm across flats for 3127, 16 mm for 3085 and 3102) and an adjustable wrench. Make sure that the bearing is pressed all the way to the bottom.

If the pump is specially approved, the gap between the bearing holder and the distance sleeve should be measured as described in the section "Specially approved pumps".
--

- 62-63. Grease the O-ring and assemble the bearing cover with the bearing holder.
64. Tighten the screws.

65. Mechanical face seal picture description.

Assembling the inner seal unit and oil housing.

66. Grease the O-ring and fit the O-ring into its seat in the bearing cover.

Exploded view

3085.891

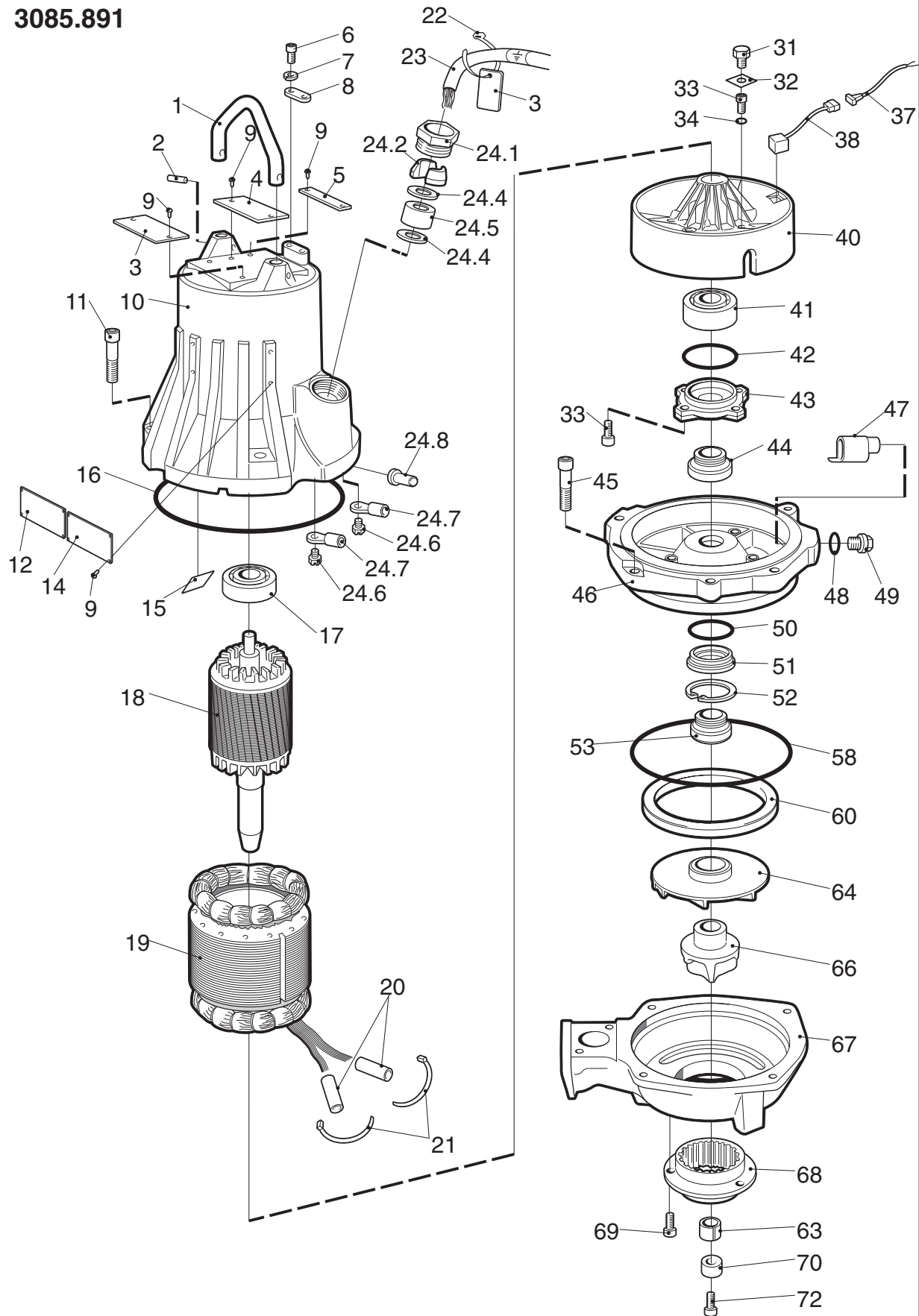

Exploded view

3102.090

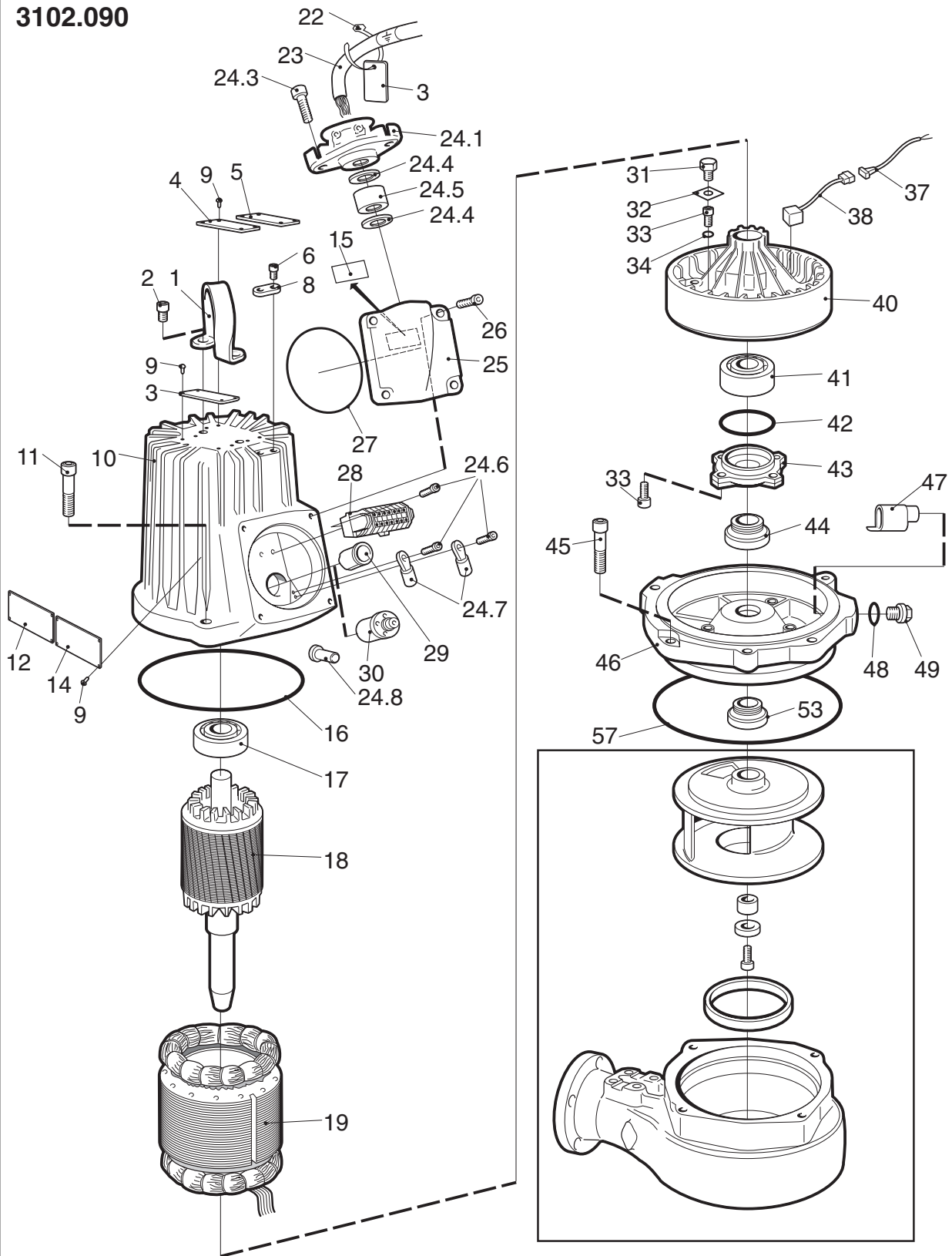

Exploded view

3102.170

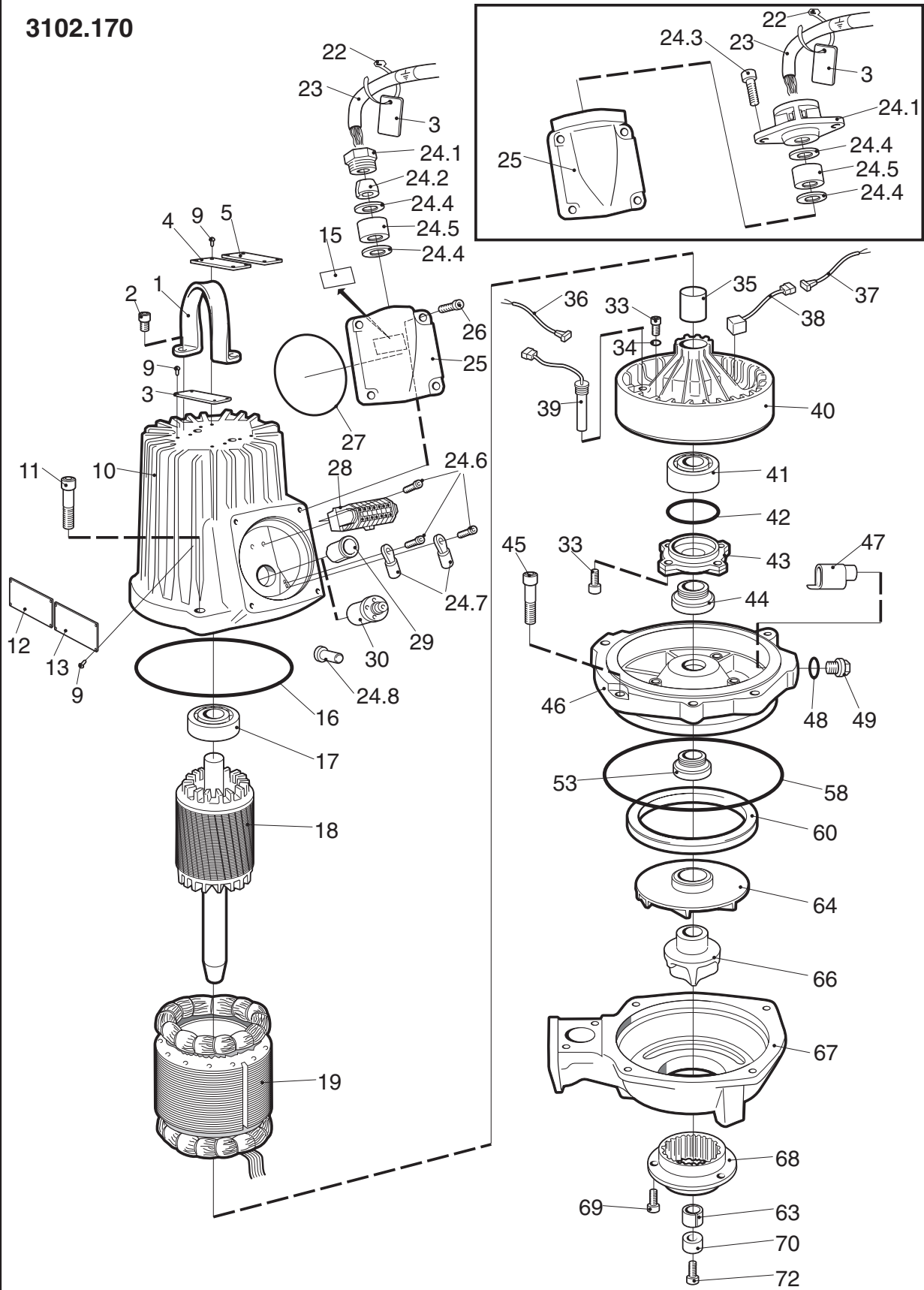

67. Fit the inner stationary seal ring to its seat. Use a suitable plastic sleeve that fits outside the sealing surface. Recommended sleeve: SKF bearing mounting kit. Make sure you fit the ring with the correct surface out (smooth, shining).
68. Stationary seal ring.
69. Apply oil to the sealing surface.
70. Fit the inner rotating seal unit to the shaft.
71. Assemble the grip ring with the seal tool.
72. Check the gap for the inner seal unit. **Gap = 1.5 mm (1/16")**.
73. Assemble the oil housing. NOTE! Check that the sleeve for the oil refill can pass unobstructed from the cut outs in the bearing holder.
74. Replace the old sealing washers by new ones.
75. Fit the 3 self-tapping screws and tighten them to a torque of 7 Nm. NOTE! If you have bought an oil housing as a spare part, there will be no threads in the 3 holes for the screws (self-tapping screws).

Assembling the outer seal unit.

- 76-77. Unpack a new outer seal unit.
78. Apply oil to the stationary seal ring.
79. Fit the seal ring together with its O-ring. Use the SKF bearing mounting kit (TMFT 33).
80. Clean the shaft and the stationary seal ring.
81. Apply oil to the rotating seal ring.
82. Grease the shaft.
- 83-84. Fit the rotating seal ring. Use the plastic sleeve in which the seal is wrapped.
85. Grip ring.
86. Fit the grip ring in the seal tool. Prepare the grip ring in the tool.
87. Fit the tool together with the grip ring to the shaft. Press the tool to the bottom and turn the Allen key. The grip ring is now in position.
88. Check the gap for the outer seal unit. **Gap = 1.5 mm (1/16")**.

3085 Cable connection.

89. Pull the motor cable into the stator housing. Connect the yellow / green lead to the earth / ground connection using the specified cable lug.
- 90-91. Connect the motor cable leads to the stator leads (see the diagrams in the chapter "Cable connections"). Apply a plastic protector hoose to the leads. Check the insulation for the connections with a Megger. The insulation between the phases and between any phase and earth shall be > 1 MΩ. Assemble the junction box cover.

3102 and 3127 junction box.

92. Pull the motor cable into the junction box. Connect the leads to the terminal board as shown in the diagram in the chapter "Cable connections". Check the insulation for the connections with a Megger. The insulation between the phases and between any phase and earth shall be > 1 MΩ.

Assembling the stator housing.

93. Fit the O-ring.
94. Fit the stator housing to the oil casing. NOTE! In order to get the stator housing in the correct position, the junction box shall be positioned just above the flange where there is no hole for the screws connecting the hydraulic part. The groove for the O-ring in the stator housing must be cleaned.

If the pump is specially approved, the gap between the stator housing and the bearing cage should be measured as described in the section "Specially approved pumps".

95. Lubricate the 4 screws.
96. Tighten the screws.
97. Remove the two lifting eyes and fit the standard lifting handle. Tighten the screws. NOTE! The highest point of the handle should be oriented away from the junction box.

Exploded view

3102.180

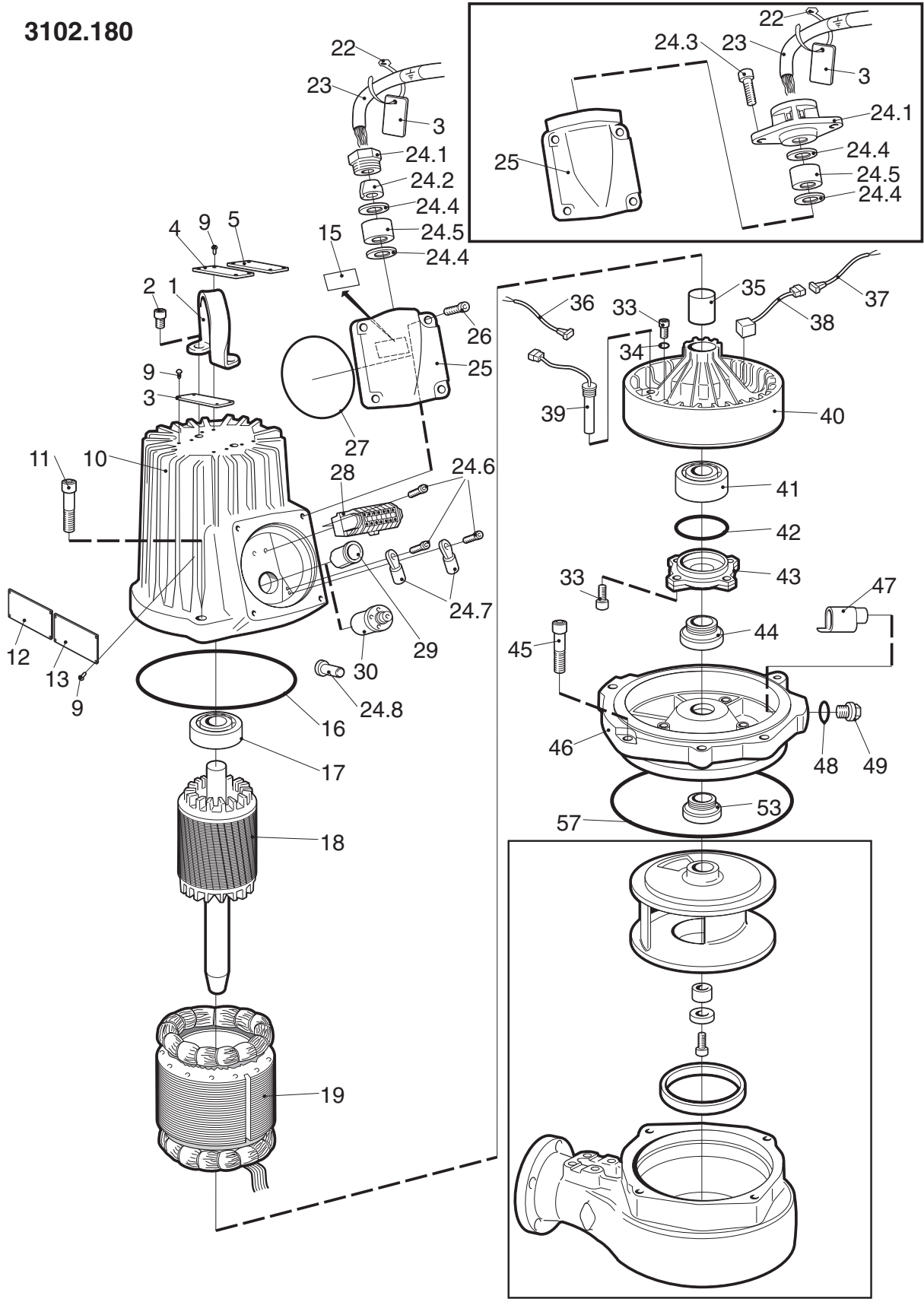

Exploded view

3102.890

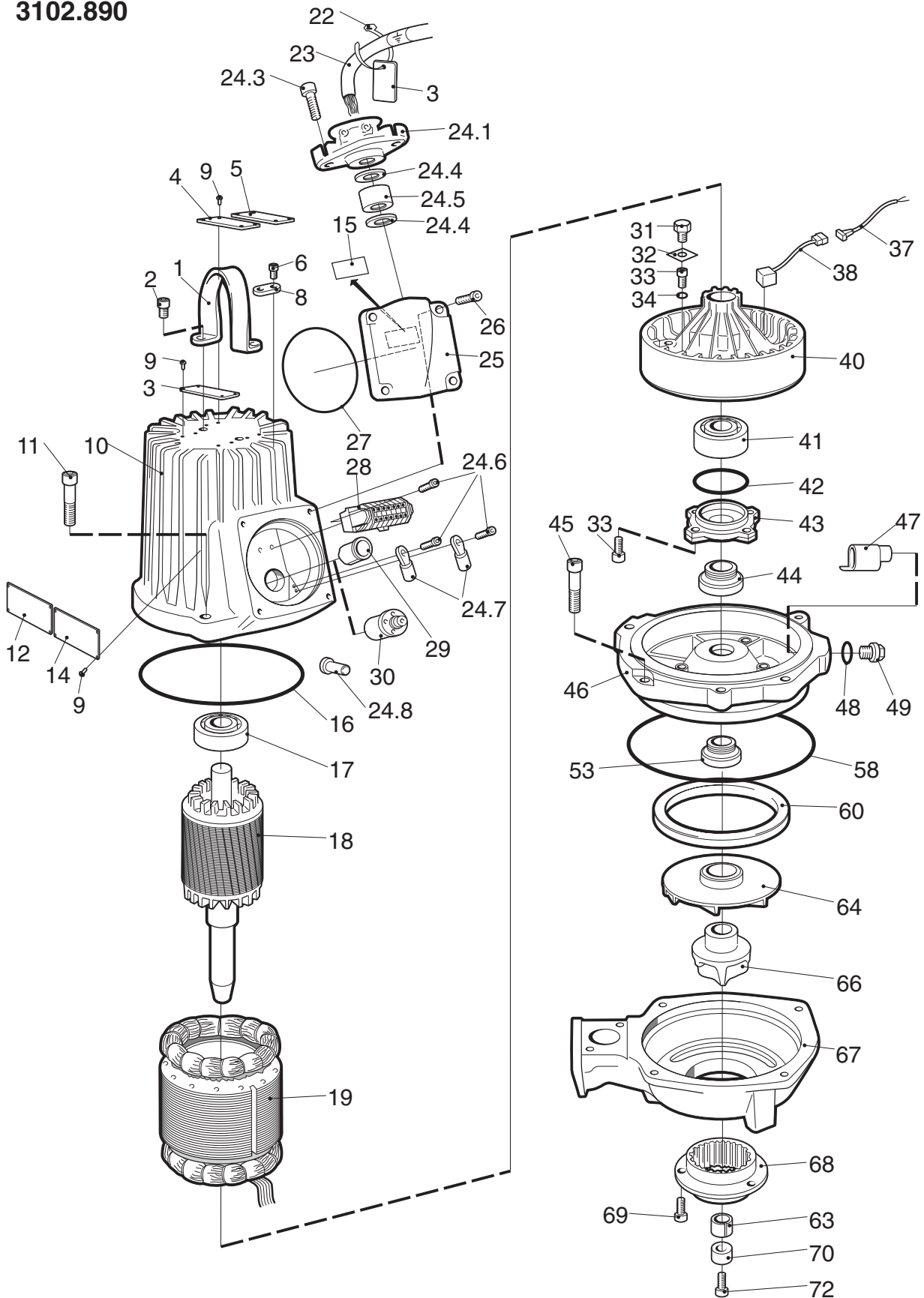

Exploded view

3127.090

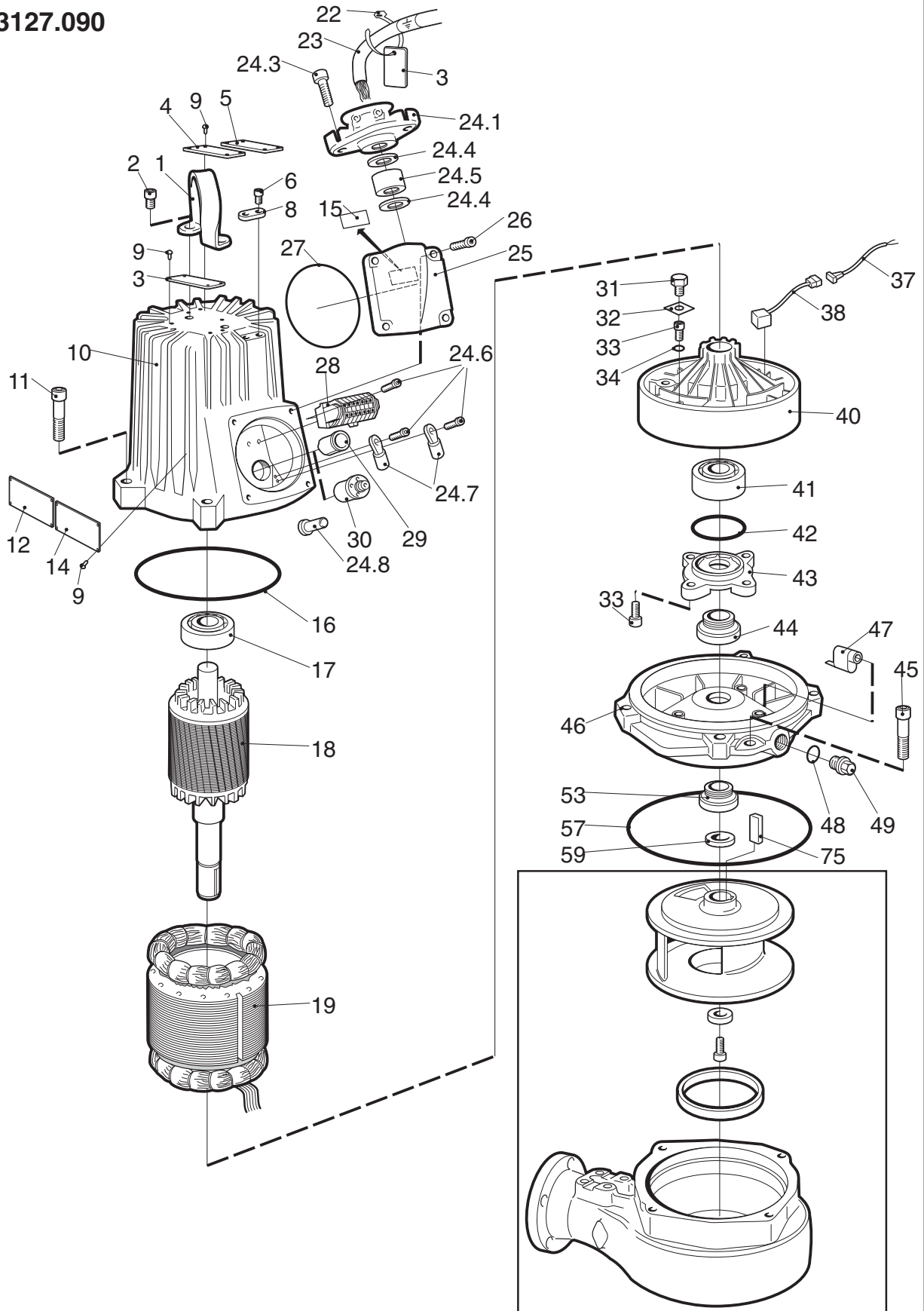

Assembling the impeller.

98. Fit the spacer ring (only 3127).
99. Fit the key in the keyway (only for 3127). Grease the shaft (NOTE! for 3085 and 3102 not on the conical part of the shaft).
100. Fit the impeller and tighten the impeller screw. Check that the impeller rotates freely. **NOTE!** If you are mounting a C 3102 LT impeller, you have to pull out the impeller a couple of mm in order for the impeller not to get jammed to the oil housing bottom.
101. Fit the "oil out" screw. Fill the pump with the appropriate type of oil and the correct volume.
102. Fit a new O-ring on and tighten the "oil in" screw.

Replacing the wear ring.

103. Bend out the wear ring at a suitable point with a crowbar.
104. Knock out the wear ring using a chisel.
105. Drive in the new wear ring. Use a rubber mallet or a wooden block to prevent deformation.
106. Assemble the pump housing.
107. Lubricate the 5 screws.
108. Tighten the screws.
109. Fit the sliding bracket.

Grinder. Replacing the impeller and the grinder device.

110. M 3102. **Warning!** The impeller and the grinder device have very sharp edges.
- 111-112. Remove the 4 bolts and lift the motor section off the pump housing.
- 113-114. Remove the impeller screw and washer. Fit the impeller screw back again.
115. Fit the impeller puller and place a protector between the screw head and the puller. Pull off the impeller.
116. Cutter wheel, impeller and conical sleeve.
117. Mount the sleeve, a new impeller and the cutter wheel. Make sure that the end of the shaft is clean and free from burrs. Polish off any flaws with a fine emerycloth.
118. Fit the washer and impeller screw, but don't tighten the screw. Measure the distance between the vanes of the impeller and the shoulder for the pump housing on the oil housing bottom. Use a straight-edge and a vernier.

Product	Type	Phases	Frequency	Distance
3085	LT,HT	1/3	50,60	43.5 ± 0.3 mm
3102	LT	1	60	43.5 ± 0.3 mm
3102	LT	3	50,60	46.0 ± 0.3 mm
3102	HT	1/3	50,60	43.5 ± 0.3 mm
3127	LT,HT	3	50	65.0 ± 0.3 mm
3127	LT,HT	3	60	65.0 ± 0.3 mm
3127	LT	1	60	63.0 ± 0.3 mm
3127	HT	1	60	65.0 ± 0.3 mm

119. At the right distance, tighten the screw quickly so that the conical sleeve grips properly. Check that the impeller can be rotated by hand.
120. When the impeller and cutter are replaced, the cutter ring in the pump housing should also be replaced.
121. Remove the screws and dismantle the cover.
122. Knock out the cutter ring from the inside of the pump casing.
123. Replace the cutter ring with a new one. Knock the new ring into its position. Mount the cover and the screws and tighten the screws.
124. Assemble the motor unit and the pump housing. Don't forget the O-ring, which must be lubricated. **NOTE!** The orientation of the pump housing.
125. Tighten the screws.

Exploded view

3127.170

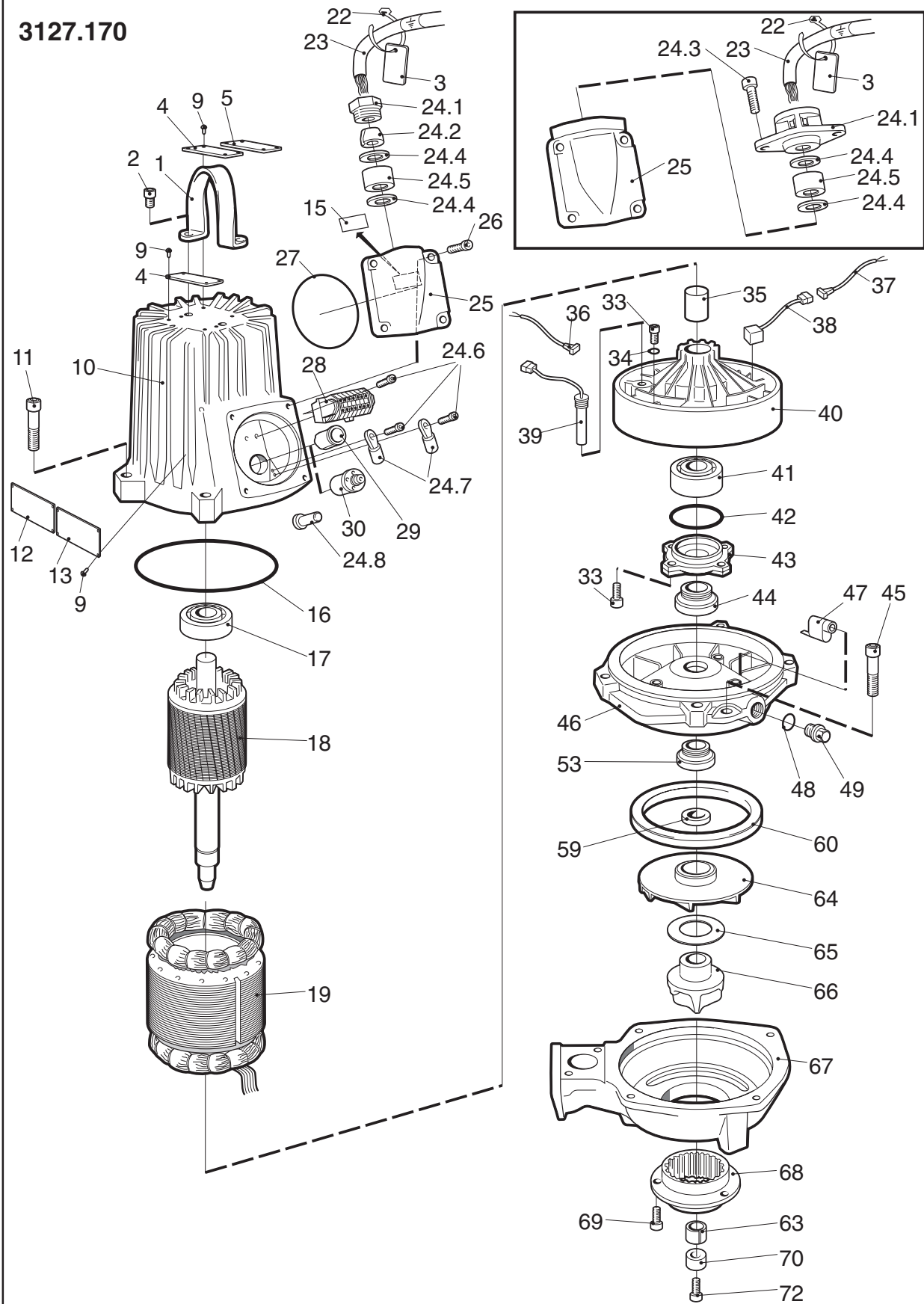

Exploded view

3127.180

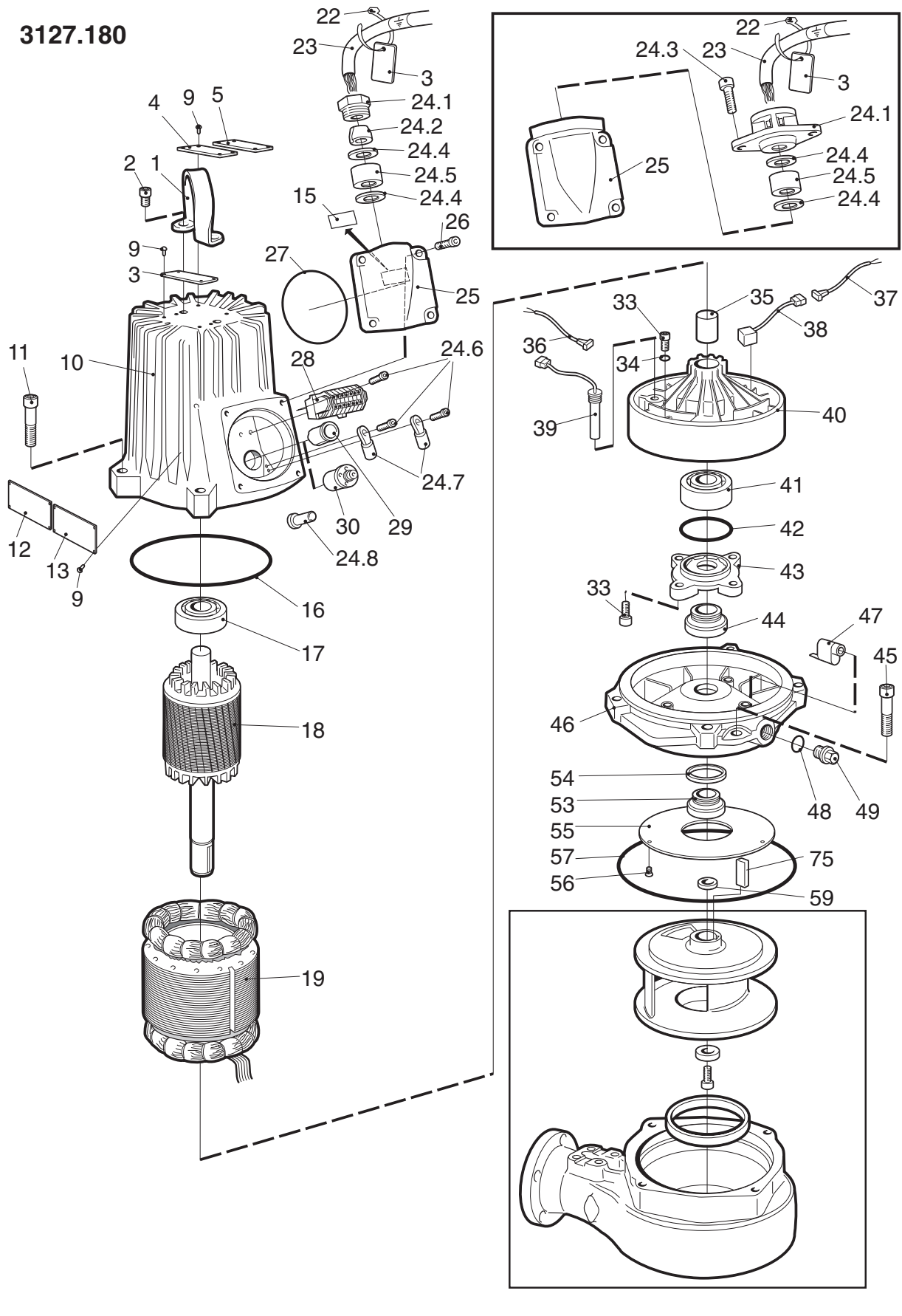

Exploded view

3127.890

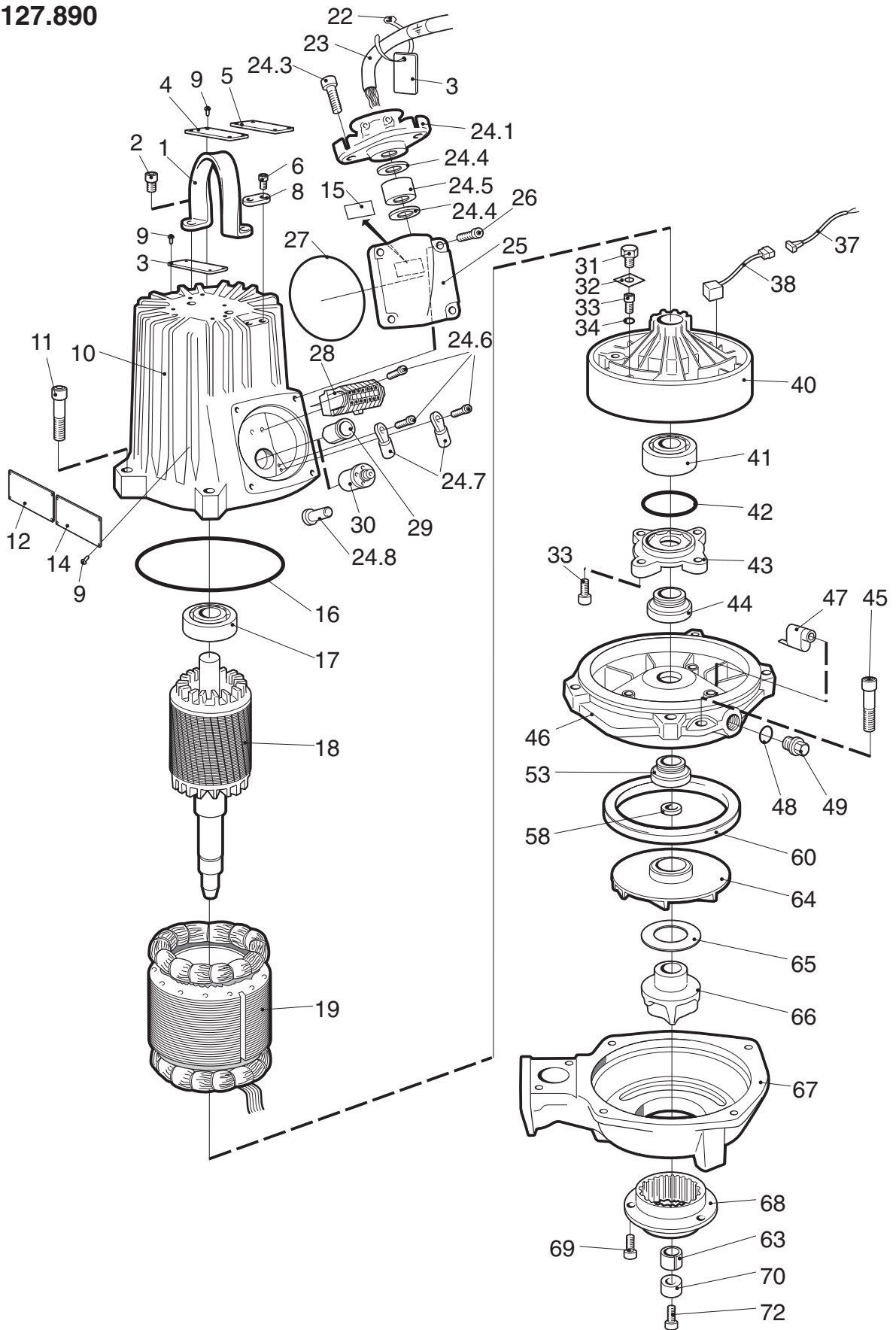

Replacing and adjusting the F type impeller.

126. F 3085. **Warning!** The impeller and the cover device have very sharp edges. The **F impellers** require an adjustment in order to achieve correct cutting ability.
- 127-128. Remove the 4 bolts and lift the motor section off the pump housing.
129. Remove the impeller screw. It is advisable to use industrial gloves as protection against sharp edges.
130. Impeller, screw, conical sleeve, washer and adjusting washers.
131. Remove the cover and the O-ring.
132. Remove the 4 bolts which hold the pump housing bottom.
133. Remove the pump housing bottom. Use a crowbar.
134. Remove the O-ring and the adjusting washers.
135. Assembling. Start by placing the cover in the pump casing. Check that the guide boss fits into the corresponding recess of the pump casing.
136. Fit the O-ring into its groove.
137. Assemble the motor.
138. Tighten the bolts.
139. Impeller, adjusting washers and conical sleeve. The play should be adjusted by means of adjusting washers, 1 mm (0.04") and 0.25 mm (0.01").
140. Fit the impeller and tighten the impeller screw. Prevent the impeller from rotating by using, for example, a piece of wood in order not to damage the sharp edges.
141. Measure the play. The play between the tightened impeller's upper edge and the cover should be 0.5-1.5 mm (0.02"-0.06").
142. Fit a new lubricated O-ring into its groove.
143. Use adjusting washers for adjusting the pump housing bottom.
144. Fit the pump housing bottom and tighten the screws.
145. Measure the play. The play between the impeller and the pump housing bottom should be 0.5-1mm (0.02"-0.04").

Replacing the impeller of swirl (vortex) type.

- 146-147. D 3102. Remove the 4 bolts and lift the motor section off the pump housing.
148. Remove the impeller screw. **Warning!** Worn impellers often have very sharp edges.
149. Pull off the impeller. Use, for example, two crowbars.
150. Impeller, conical sleeve, impeller screw and washers.
151. Assembling. Make sure that the end of the shaft is clean and free from burrs. Polish off any flaws with a fine emerycloth. Fit the conical sleeve into the impeller and fit the impeller on the shaft.
152. Tighten the impeller screw.
153. Fit a new lubricated O-ring in the groove on the oil housing bottom.
154. Assemble the motor on the hydraulic unit.
155. Tighten the screws.





Specially approved pumps

Specially approved pumps

NOTE!

Specially approved pumps may only be repaired or maintained by authorized Flygt personnel or personnel authorized by Flygt.



This workshop manual also describes the specially approved pumps in the product series 3085, 3102 and 3127. For identification, see the pump data plate and approval plate.

To ensure that the pump complies with the regulations and approval of the authorities, use only genuine Flygt spare parts when carrying out repair work.

Always check the dimensions of vital parts before assembly. See picture below.

The assembled pumps shall always be insulation-tested and test-run before delivery.

General

In a specially approved pump (Ex d), the gaps between different parts, for example between the stator housing and the junction box, shall prevent any sparks from the interior of the pump from getting out and igniting surrounding gases.

All joint widths and gaps shall be measured with accurate and calibrated instruments. All joint surfaces shall be inspected. No scratches, tool marks or the like are permissible.

Failure to meet the above requirements may render the special approval **invalid**. Note that the work requires experienced and specially trained personnel.

Workshop repair

The parts for which dimensions are to be checked are given in the parts list. It is important to ensure that the joint surfaces for these parts are not damaged during dismantling.

The product must be thoroughly examined and a report must be prepared on all findings. Any measurements, dimensional checks, test readings, details of materials, parts of windings which are found to require attention should be carefully noted.

If the products have been modified and do not comply with original approval, the owner must be informed and further information on the application must be requested.

If there are any doubts during the repair as to the results of measurements, tests, the continued integrity of parts or the possible reclamation of damage parts, reference must be made to your local Ex Coordinator.

Guidelines for repair

Care must be taken when dismantling Ex approved products, as damage to flameproof faces can easily occur. For instance, if difficulties are found in separating spigoted joints, draw studs should be used wherever possible rather than trying to wedge the components apart, as not only will damage occur at the point of wedging, but the wedges are liable to be driven through and damage the flamepath surface of the spigot. Similarly, care should be exercised when removing the main bearing assembly and bearing cover to ensure that damage does not occur on the part of the shaft that constitutes the flamepath.

Specially approved pumps

Unless obviously damaged through either mechanical injury or dry or wet burn out, the stator winding should not be removed until preliminary testing has been done to determine the condition of the stator winding and monitoring devices, i.e. overtemperature thermal switches. The moisture detection device (FLS) in the stator housing is separate and does not form part of the stator winding.

The user's instruction should be consulted to verify whether the pump has been returned for repair because of electrical problems, such as operation of overload, short circuit or tripping out on an earth trip leakage device.

Once the pump has been completely dismantled, detailed examination of all parts should be made and a concise record kept of all findings.

When assembling an Ex approved product, measure the gaps and the joint widths. Inspect the joint surfaces and smear them with grease to prevent corrosion.

If a part does not meet the requirements on dimensional accuracy or surface finish, it must be discarded and a new specially approved part ordered. The new part must also be inspected.

Observe caution during assembly to prevent damage to the joint surfaces.

Flamepaths

By referring to the spare parts list and dimensional drawings, the trained person can ascertain the parts of the pump motor that require special examination. The flamepaths should be examined for any corrosive pitting or damage which may have occurred.

All castings should be examined for blow holes or hairline cracks. If there is evidence that there has been an internal explosion of gases, this may be confirmed by the user and will probably be evident by smoke and debris tracking across the flamepaths.

Also violent damage will possibly have occurred to the stator windings, stator leads and terminal boards or bushings. In such cases, consideration should be given to the renewal of all parts forming the flameproof enclosure.

Using the FLYGT dimensional check information for Ex approved products for the particular product under repair, the length of all flamepaths can be measured using a vernier type gauge (the type incorporating a depth gauge is particularly suitable for this purpose). When measuring flamepaths on spigoted parts, care should be taken to measure only from the outer edge of the flamepath to the outer edge of the "O" ring groove. It would, however, be unusual for these measurements to be wrong as any corrosive or mechanical damage affecting the length of the flamepath would be evident by visual inspection.

The flameproof gap is ascertained by measuring the outside diameter (O.D.) of the spigoted or male part and the inside diameter (I.D.) of the female part of the casting into which it fits. Measurements should be taken at several points on the circumference and the smaller (in the case of O.D.) and the larger (in the case of I.D.) should be used to calculate the diametral clearance. Micrometers should be used for taking measurements.

The calculation is simply to subtract the O.D. of the male part from the I.D. of the female part into which it fits. Care and experience is required when taking any of these measurements, as the tolerances are very fine.

For measuring the inside circumference of the stator core or the outside diameters of rotors, special measuring tools are required. Shaft outside diameter and inside diameters of bearing covers etc. can be measured using micrometers.

The flameproof gaps should be calculated, recorded and checked against the dimensional check list for the product under repair.

Specially approved pumps

Stator and rotor

Prior to examining the stator housing, preliminary electrical testing of the stator winding should be undertaken. This requires an insulation test between windings and earth and between windings, for single phase also between windings and auxiliaries.

The two monitoring cores should be short circuited together during this test. A suitable test with a 100 volt megger would be 20 M Ω .

The continuity of the thermal switches should be measured to ensure their continued integrity. In the rare case when thermistors and PT100 elements are used, they can be tested using a digital type high impedance instrument.

Specially approved pumps

Dimensional checks

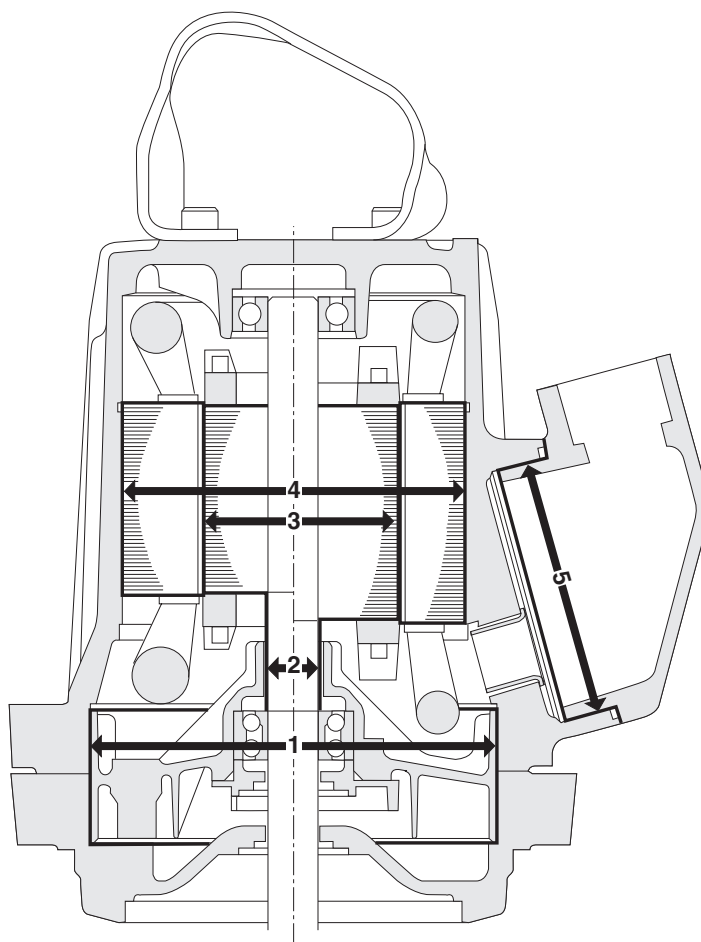

3085.092 / .891

	With of joint (mm)	Diameter (mm)	Gap of joint (mm)	
			Min	Max
1	≥ 15.5	202 H7 202 f8	0.122	0.168
2	≥ 26	30 H7 30 ^{-0.255} _{-0.274}	0.255	0.295
3	65	89 ± 0.03 88.2 ± 0.05	0.72	0.88
	85	79 ± 0.03 78.3 ± 0.06	0.61	0.79
	97	89 ± 0.03 88.2 ± 0.05	0.72	0.88
4	65 (4-pole)	145 JS7 145 ^{+0.1} _{+0.02}	Shrink fit	
	85 (2-pole)	145 JS7 145 ^{+0.083} _{+0.02}		
	97 (4-pole)	145 JS7 145 ^{+0.1} _{+0.02}		
	97 (6-pole)	145 JS7 145 ^{+0.1} _{+0.02}		

Specially approved pumps

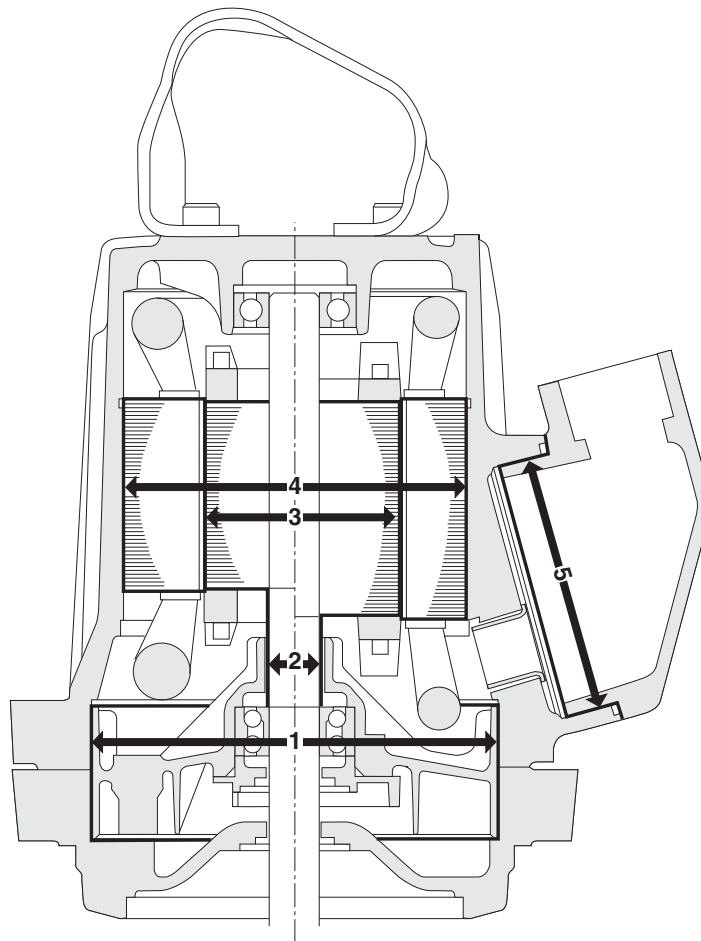

3102.090 / .890

	With of joint (mm)	Diameter (mm)	Gap of joint (mm)	
			Min	Max
1	≥ 25	205 H8 202 f8	0.050	0.194
2	≥ 25	30 H7 30 ^{-0.255} / _{-0.274}	0.255	0.296
3	95	95.0 ± 0.030 94.2 ± 0.050	0.72	0.88
	110	110.0 ± 0.030 109.2 ± 0.050	0.72	0.88
4	91 (2-pole) 106 (4-pole)	175 P7 175 ^{+0.050} / _{-0.013}	Shrink fit	
5	≥ 25	130 H8 130 f8	0.043	0.169

Specially approved pumps

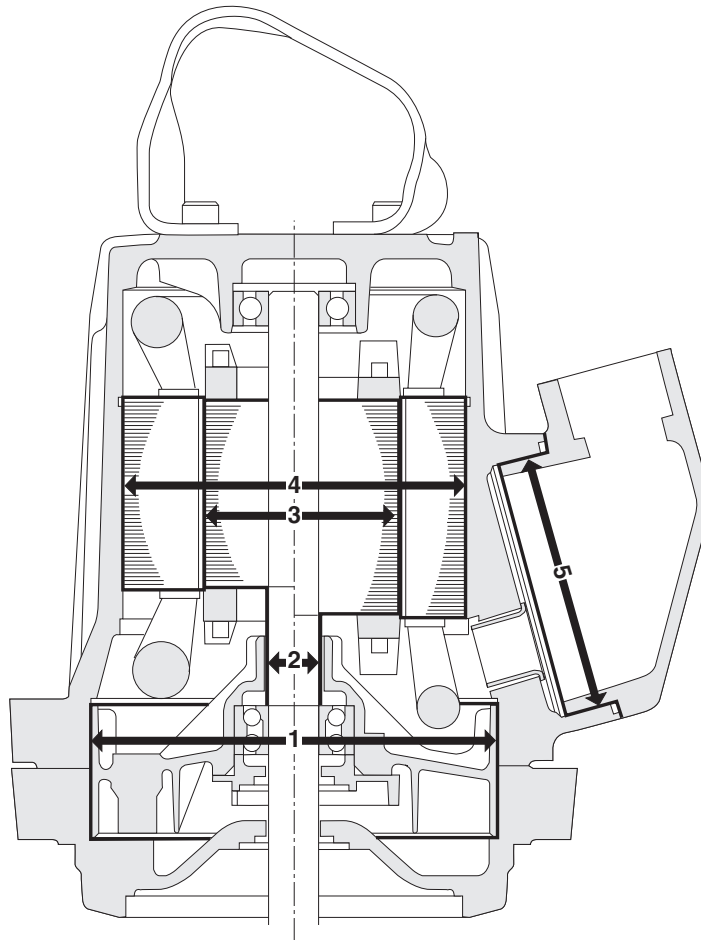

3127.090 / .890

	With of joint (mm)	Diameter (mm)	Gap of joint (mm)	
			Min	Max
1	≥ 25	244 H8 244 f8	0.050	0.194
2	≥ 25	45 ^{+0.195} _{+0.170} 45 d7	0.250	0.300
3	105 (2-pole)	114.1 - 115.0	0.87	1.03
	95/115 (4 pole)	133.0 - 134.0	0.97	1.13
4	103 (2-pole) 93/113 (4-pole)	210 P7 210 ^{+0.052} _{-0.020}	Shrink fit	
5	≥ 25	130 H8 130 f8	0.043	0.169

