

APPROVED

# INSTALLATION, CARE AND MAINTENANCE



# DATA PLATES INTERPRETATION

## General data plate

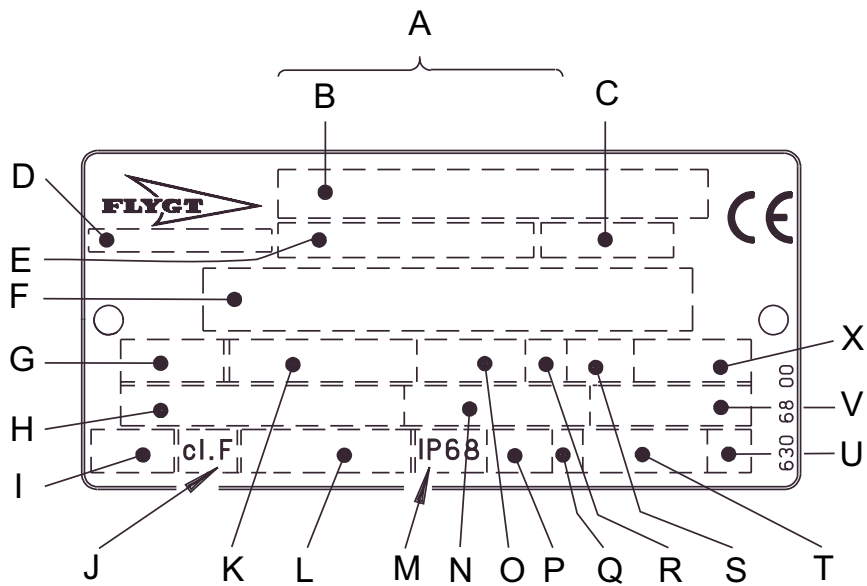

- |   |                                   |   |  |
|---|-----------------------------------|---|--|
| A | Serial number                     | M | Degree of protection                   |
| B | Product code + Number             | N | Rated current                          |
| C | Curve code / Propeller code       | O | Rated speed                            |
| D | Country of origin                 | P | Max. submergence                       |
| E | Product number                    | Q | Direction of rotation: L=left, R=right |
| F | Additional information            | R | Duty class                             |
| G | Phase; Type of current; Frequency | S | Duty factor                            |
| H | Rated voltage                     | T | Product weight                         |
| I | Thermal protection                | U | Locked rotor code letter               |
| J | Thermal class                     | V | Power factor                           |
| K | Rated shaft power                 | X | Max. ambient temperature               |
| L | International standard            |   |  |

# DATA PLATES INTERPRETATION

## Approval plates

These approval plates apply to an explosion-proof submersible Flygt pump.  
The plates are used together with the general data plate on the pump.

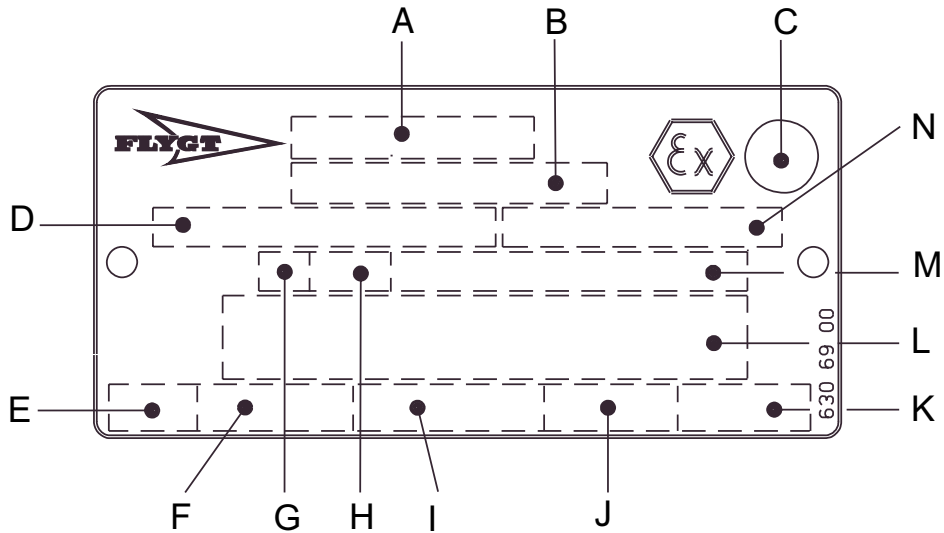

- |   |                                      |   |                          |
|---|--------------------------------------|---|--------------------------|
| A | Approval                             | H | Duty factor              |
| B | Approval authority + Approval Number | I | Input power              |
| C | Approval for Class I                 | J | Rated speed              |
| D | Approved drive unit                  | K | Controller               |
| E | Stall time                           | L | Additional information   |
| F | Starting current / Rated current     | M | Max. ambient temperature |
| G | Duty class                           | N | Serial number            |

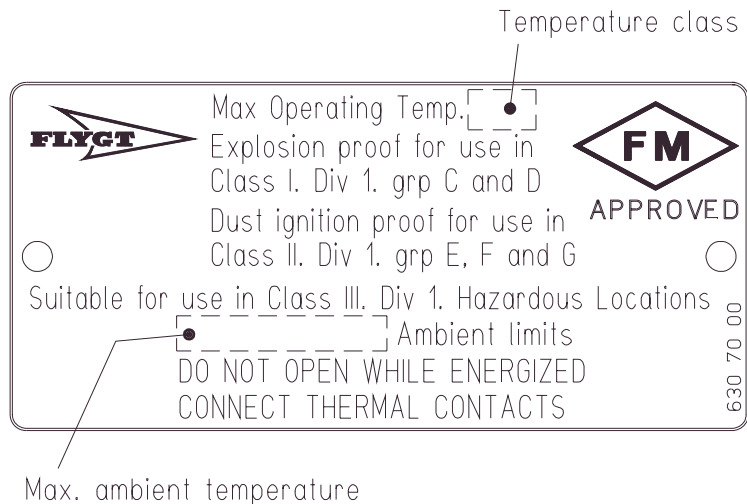

# GUARANTEE

Flygt undertakes to remedy faults in products sold by Flygt provided:

- that the fault is due to defects in design, materials or workmanship;
- that the fault is reported to Flygt or Flygt's representative during the guarantee period;
- that the product is used only under conditions described in the care and maintenance instructions and in applications for which it is intended;
- that the monitoring equipment incorporated in the product is correctly connected;
- that all service and repair work is done by a workshop authorized by Flygt;
- that genuine Flygt parts are used.

Hence, the guarantee does not cover faults caused by deficient maintenance, improper installation, incorrectly executed repair work or normal wear and tear.

Flygt assumes no liability for either bodily injuries, material damages or economic losses beyond what is stated above.

Flygt guarantees that a spare parts stock will be kept for 15 years after the manufacture of this product has been discontinued.

The manufacturer reserves the right to alter performance, specification or design without notice.

## Official approvals apply only providing:

- that the product is used under conditions described in the care and maintenance instructions and in applications for which it is intended;
- that the monitoring equipment incorporated in the product is correctly connected;
- that all service and repair work is done by a workshop authorized by Flygt;
- that genuine Flygt parts are used.

# CONTENTS

<b>Product description</b> _____	6	<b>Operation</b> _____	17
Approvals _____	6	Before starting _____	17
Applications _____	6	Leakage sensor _____	17
Weights _____	6	<b>Care and maintenance</b> _____	19
Motor data _____	6	Safety precautions _____	19
Materials _____	7	Inspection _____	19
Design _____	7	Changing the oil _____	21
Performance curves _____	9	Replacing the wear ring _____	22
<b>Transportation and storage</b> _____	10	Replacing the impeller _____	23
<b>Installation</b> _____	10	<b>Fault tracing (Troubleshooting)</b> _____	25
Safety precautions _____	10	<b>Accessories and tools</b> _____	29
Handling equipment _____	10	<b>Service log</b> _____	30
Installation alternatives _____	11	<b>Cutaway view</b> _____	31
Dimensional drawings _____	12		
<b>Electrical connections</b> _____	14		

**MATÉRIEL ÉLECTRIQUE UTILISABLE EN ATMOSPHÈRE EXPLOSIBLE****(1) CERTIFICAT DE CONFORMITÉ**

(2) CERCHAR 83.5033 X

(3) Le présent certificat est délivré pour le matériel électrique :

MOTEUR ELECTRIQUE TYPE 463 56 00

(4) Construit par : FLYGT A B - LINDAS (Suède)

et soumis à la certification par : FLYGT - FRANCE S.A.  
35, rue J.J. Rousseau  
92153 SURESNES

(5) Ce matériel électrique et ses variantes éventuelles acceptées, sont décrits dans l'annexe de ce certificat et dans les documents descriptifs cités dans cette annexe.

(6) Le CERCHAR, organisme agréé conformément à l'article 14 de la Directive du Conseil des Communautés Européennes 78/117/CEE du 18.12.1975.

- certifie que ce matériel électrique est conforme aux Normes Européennes qui lui sont applicables, soit :

EN 50 014 - 1977 (NF C 23-514)

EN 50 018 - 1977 (NF C 23-518)

- et qu'il a subi avec succès les vérifications et épreuves de type prescrites par ces normes.

- certifie avoir établi un procès-verbal confidentiel de ces vérifications et épreuves.

(7) Le marquage du Matériel électrique doit comporter le code suivant :

EEx d IIB T4

(8) Par le marquage du matériel électrique livré, le fournisseur atteste, sous sa propre responsabilité, que ce matériel est conforme aux documents descriptifs cités dans l'annexe et qu'il a subi avec succès les vérifications et épreuves individuelles prescrites par les Normes Européennes mentionnées en (6). Ces vérifications et épreuves sont rappelées dans l'annexe.

(9) Ce matériel électrique est autorisé à porter la marque distinctive communautaire définie dans l'annexe II de la Directive 79/196/CEE du 6 Février 1979.

Cette marque figure sur la première page du présent certificat.



Verneuil-en-Halatte, le 1983 09 06

Le Directeur de l'Organisme Certificateur.

Par délégation, le  
Chef du Groupe Agrément-Sécurité.

CODE : EEx d IIB T4

Ce document ne peut être reproduit que dans son intégralité

Folio 1 / 4

CODE : EEx d IIB T4

Ce document ne peut être reproduit que dans son intégralité

Folio 2 / 4

Certificat CERCHAR 83.5033 X Date 1983 09 06

**A N N E X E**MOTEUR ELECTRIQUE TYPE 463 56 00**DESCRIPTION -**

Moteur électrique antidéflagrant avec carcasse en acier inoxydable destiné à l'entraînement d'un malaxeur.

**DOCUMENTS DESCRIPTIFS -**- notice descriptive 105/BM/JR/136/83 du 1.07.83  
- plan n° 463 56 00 du 20.10.82**MARQUAGE -**

Ce matériel doit porter le marquage suivant :

FLYGT  
463 56 00  
EEx d IIB T4  
CERCHAR 83.5033 X  
(Numéro de fabrication)

ainsi que la mention :

"Brancher les thermosondes"

De plus, ce matériel doit porter le marquage normalement prévu par les normes de construction du matériel électrique.

**PARAMETRES ELECTRIQUES RELATIFS A LA SECURITE -**

P max. à 50 Hz : 2 kW à 1 400 tr/min

CODE : EEx d IIB T4

Ce document ne peut être reproduit que dans son intégralité

Folio 3 / 4

Certificat CERCHAR 83.5033 X Date 1983 09 06

**A N N E X E (suite)****EPREUVE INDIVIDUELLE -**

Compte tenu d'une épreuve de surpression statique effectuée sous 4 fois la pression de référence, ce matériel est dispensé d'épreuve individuelle de surpression, conformément à 15.2 de la norme EN 50 018.

**CONDITIONS SPECIALES D'UTILISATION -**

Les conditions spéciales pour une utilisation sûre de ce matériel sont les suivantes :

- les sondes thermiques équipant les enroulements du moteur doivent être reliées à des circuits de protection appropriés.

CODE : EEx d IIB T4

Ce document ne peut être reproduit que dans son intégralité

Folio 4 / 4

# PRODUCT DESCRIPTION

## Approvals

These care and maintenance instructions apply to an explosion-proof submersible Flygt pump.

The pump is designed for use in explosive environments in accordance with the following approvals:

- EN: European Norm  
EN 50014, EN 50018, EEx dII T4
- FM Factory Mutual  
Class I Div. 1 Grp C and D  
Class II and III Div. 1 Grp E, F and G

## Applications

3085.290 is a stainless steel pump intended to be used for pumping of corrosive industrial waste water and sludge.

The pump is available in the following versions:

- CP/DP** = for permanent installation in a sump. The pump slides down along the guide arrangement and connects automatically to a discharge connection.
- CS/DS** = portable, with hose connection and stand.
- BP** = for permanent installation in a sump. The pump slides down along the guide arrangement and connects automatically to a discharge connection. The pump is equipped with a multi-vane impeller for high pressures.
- BS** = portable, with hose connection and equipped with a multi-vane impeller for high pressures.
- MT** = medium-head version
- HT** = high-head version

**Liquid temperature:** max. 40°C (105°F)

**Liquid density:** max. 1100 kg/m<sup>3</sup> (9.2 lb per US gal.)

**The pH of the pumped liquid:** 3—14

**Lowest liquid level:** At least half of the stator housing shall be covered by the pumped liquid in order to accomplish satisfactory cooling.

The pumped liquid may contain particles up to a size which correspond to the throughlet of the pump.

**Depth of immersion:** max. 20 m (65 ft).

For other applications, than the above, contact your nearest Flygt representative for information.

## Weights

Weight without motor cable and accessories:

Version	kg (lb)
<b>CP/CS 3085 MT</b>	67 (147.5)
<b>DP/DS 3085 MT</b>	68 (150)
<b>BP/BS 3085 HT</b>	58 (128)

## Motor data

**Rated output: 2.4 kW, 3 ~ 50 Hz 2830 r/min**

Voltage V	Rated current A	Starting current A
220 VΔ	8.5 A	50 A
380 VΔ	5.0 A	28 A
415 VY	4.5 A	25 A
440 VY	4.3 A	27 A
550 VY	3.5 A	22 A

**Rated output: 2.0 kW, 3 ~ 50 Hz 1395 r/min**

Voltage V	Rated current A	Starting current A
220 VΔ	8.4 A	39 A
380 VΔ	4.9 A	23 A
415 VY	4.4 A	20 A
440 VY	4.3 A	22 A
550 VY	3.5 A	17 A

**Rated output: 3.0 kW, (4.0 hp), 3 ~ 60 Hz 3430 r/min**

Voltage V	Rated current A	Starting current A
200 VY	12.0 A	63 A
230 VΔ	10.0 A	53 A
460 VY	5.0 A	30 A
575 VY	4.0 A	20 A
600 VY	3.8 A	23 A

**Rated output: 2.2 kW, (3.0 hp), 3 ~ 60 Hz 1700 r/min**

Voltage V	Rated current A	Starting current A
200 VY	9.9 A	51 A
230 VΔ	9.0 A	48 A
460 VY	4.5 A	24 A
575 VY	3.4 A	16 A
600 VY	3.3 A	18 A

## Materials

		DIN	BS	ANSI
Major Castings	Stainless Steel			
Lifting Handle	Stainless Steel	17440	970	ASTM
		1972	Part 4	A320
		X5CrNi	1970	1982
		Mo18 12	316S33	AISI
		W.no 1.4436		316
Shaft	Stainless Steel	17440		AISI
		17455		329
		17456		UNS/
		X8CrNi		S32900
		Mo27		
		5 2		
		W.no 1.4460		
Impeller	Stainless Steel			
	Composite (PVDF SOLEF 3108, Solvay)			
Hydraulic Parts	See Major Castings			
Stationary Wear Ring	Stainless Steel	17440	970	ASTM
		1972	Part 4	A320
		X5CrNi	1970	1982
		Mo18 12	316S33	AISI
		W.no 1.4436		316
Screws, Studs and Nuts	Stainless Steel	17440	970	ASTM
		1972	Part 4	A320
		X5CrNi	1970	1982
		Mo18 12	316S33	AISI
		W.no 1.4436		316
O-Ring	Fluorinated Rubber			
Bushing for Cable Entry	Chloroprene Rubber			
Mechanical Face Seals:	Inner Stationary: tungsten carbide			
	Inner Rotating: tungsten carbide			
	Outer Stationary: silicon carbide			
	Outer Rotating: silicon carbide			
Surface Treatment:	Not applicable			

## Design

3085.290 is a submersible, electric motor-driven pump.

### 1. Impeller

The pump is available with the following types of impellers:

- single-vane, NevaClog impeller of composite (PVDF).
- vortex impeller of stainless steel.
- multi-vane impeller of stainless steel.

### 2. Shaft seals

The pump has two mechanical seals.

Materials: Inner seal: tungsten carbide — tungsten carbide.

Outer seal: silicon carbide — silicon carbide.

### 3. Shaft

The shaft is delivered with the rotor as an integral part.

Shaft material: stainless steel.

### 4. Bearings

The support bearing of the rotor consists of a single row ball bearing.

The main bearing of the rotor consists of a two-row angular contact ball bearing.

### 5. Oil housing

The oil lubricates and cools the seals and acts as a buffer between the pump housing and the electric motor.

Pressure build-up within the oil housing is reduced by means of a built-in air volume.

### 6. Motor

Squirrel-cage 3-phase induction motor for 50 Hz or 60 Hz.

The motor is started by means of direct on-line or star-delta start.

The motor can be run continuously or intermittently with a maximum of 15 evenly spaced starts per hour.

Flygt motors are tested in accordance with IEC 34-1.

The stator is insulated in accordance with class F (155°C, 310°F). The motor is designed to supply its rated output at  $\pm 5\%$  variation of the rated voltage. Without overheating the motor,  $\pm 10\%$  variation of the rated voltage can be accepted provided that the motor does not run continuously at full load. The motor is designed to operate with a voltage imbalance of up to 2% between the phases.

### Monitoring equipment

The stator incorporates thermocontacts that activate an alarm. The thermocontacts: open at 125°C (260°F).

The transducers shall be connected to Flygt's monitoring unit or equivalent unit.

The monitoring equipment shall be of a design that makes automatic restart impossible.

The pump can be equipped with sensors for sensing water in the stator housing (7).

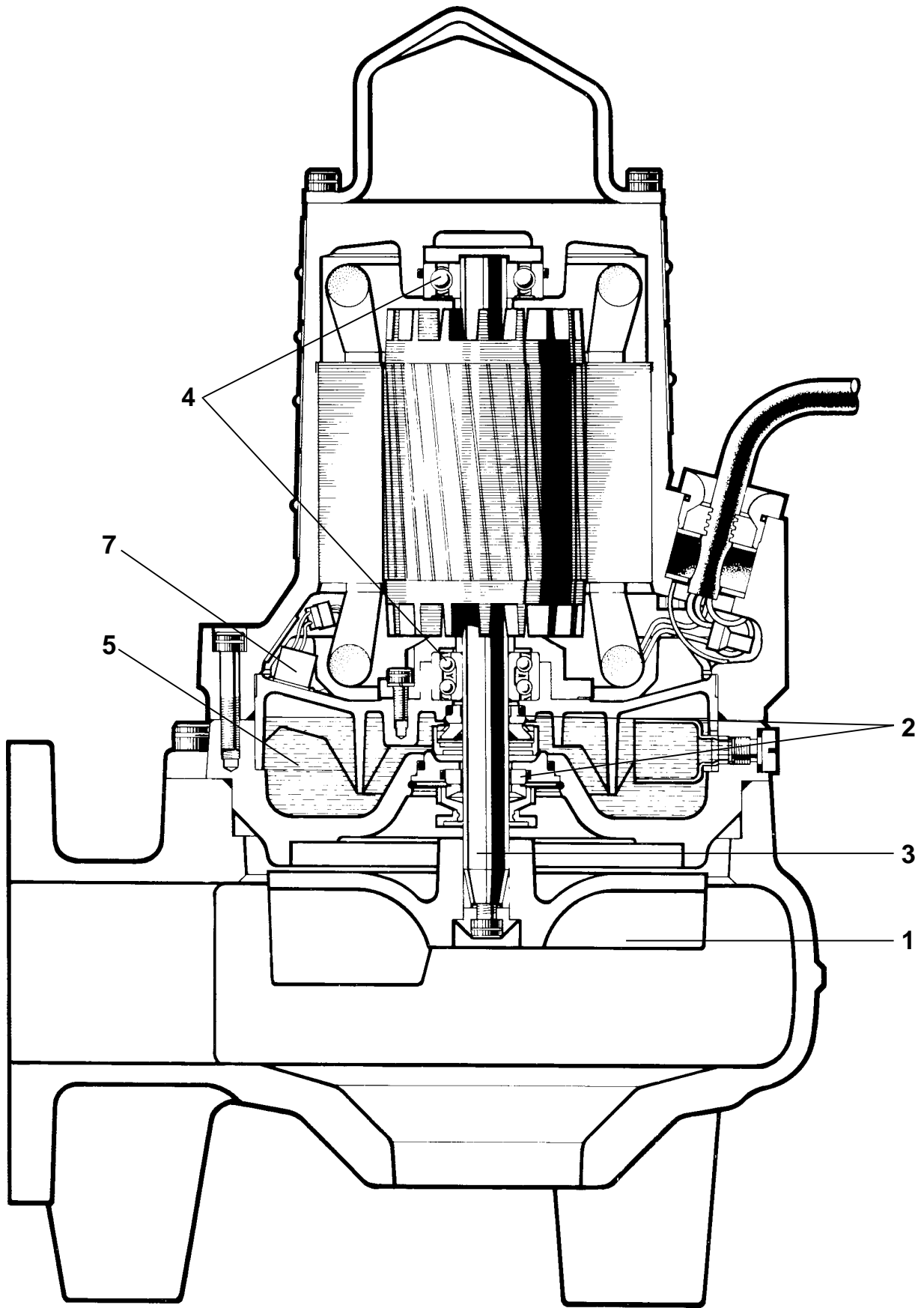



# Performance curves

Each pump is tested in accordance with ISO 2548, Class C, Annex B.

└ = Best operating point  
 2XX, 4XX = Curve number

**50 Hz C 3085 MT, NevaClog**

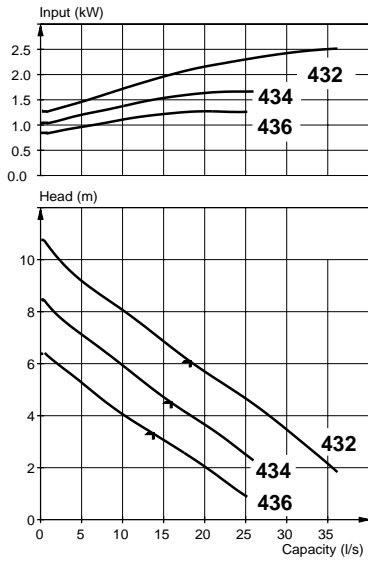

**50 Hz D 3085 MT**

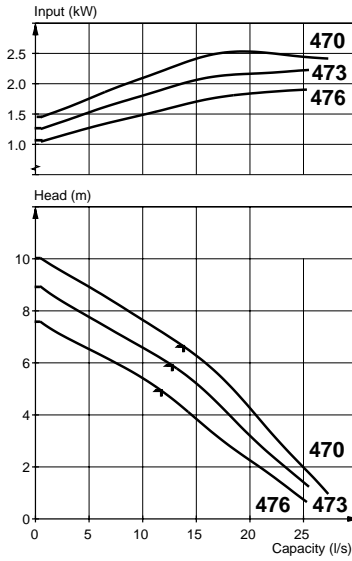

**50 Hz B 3085 HT**

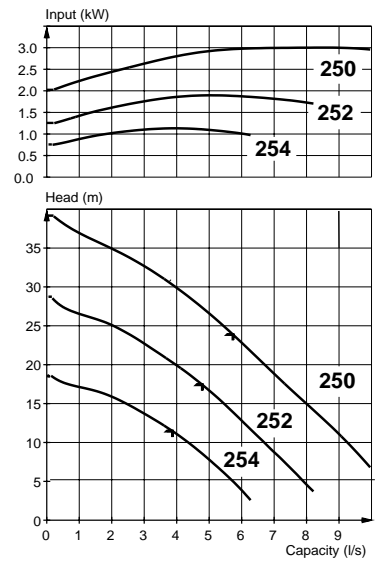

**60 Hz C 3085 MT, NevaClog**

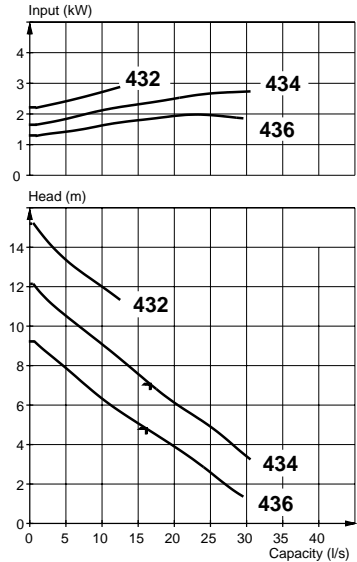

**60 Hz D 3085 MT**

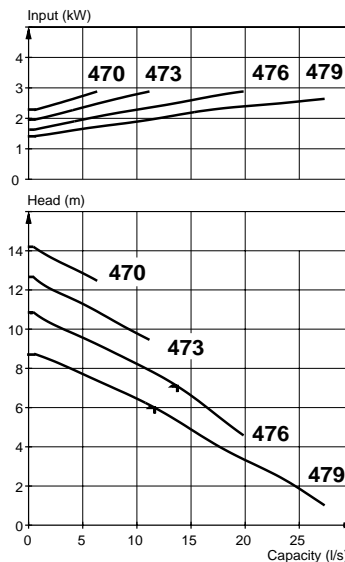

**60 Hz B 3085 HT**



# TRANSPORTATION AND STORAGE

The pump may be transported and stored in a vertical or horizontal position. Make sure that it cannot roll or fall over.

**Warning!**  
**Always lift the pump by its lifting handle or lifting eyes, never by the motor cable or the hose.**

The pump is frostproof as long as it is operating or is immersed in the liquid. If the pump is taken up when the temperature is below freezing, the impeller may freeze.

The pump shall be operated for a short period after being taken up in order to expel all remaining water.

A frozen impeller can be thawed by allowing the pump to stand immersed in the liquid for a short period before it is started. Never use a naked flame to thaw the pump.

For longer periods of storage, the pump must be protected against moisture and heat. The impeller should be rotated by hand occasionally (for example every other month) to prevent the seals from sticking together. If the pump is stored for more than 6 months, this rotation is mandatory.

After a long period of storage, the pump should be inspected before it is put into operation. Pay special attention to the seals and the cable entry.

Follow the instructions under the heading "Before starting".

# INSTALLATION

## Safety precautions

In order to minimize the risk of accidents in connection with the service and installation work, the following rules should be followed:

1. Never work alone. Use a lifting harness (part No. 84 33 02), safety line (part No. 84 33 03) and a respirator (part No. 84 33 01), as required. Do not ignore the risk of drowning!
2. Make sure there are no poisonous gases within the work area.
3. Check the explosion risk before welding or using electric hand tools.
4. Do not ignore health hazards. Observe strict cleanliness.
5. Bear in mind the risk of electrical accidents.
6. Make sure that the lifting equipment is in good condition.
7. Provide a suitable barrier around the work area, for example a guard rail.
8. Make sure you have a clear path of retreat!
9. Use safety helmet, safety goggles and protective shoes.
10. All personnel who work with sewage systems shall be vaccinated against diseases that can occur.
11. A first-aid kit must be handy.

Follow all other health and safety rules and local codes and ordinances.

## Handling equipment

Lifting equipment is required for handling the pump.

**WARNING!** Keep out from under suspended loads.

The minimum height between the lifting hook and the floor shall be: 0.6 m (2 ft) in order to lift the pump out of the sump.

The lifting equipment shall be able to hoist the pump straight up and down in the sump, preferably without necessitating resetting the lifting hook.

Oversize lifting equipment could cause damage if pump gets stuck when being lifted.

Make sure that the lifting equipment is securely anchored.

## Installation alternatives

### CP/DP/BP version

In the CP/DP/BP version, the pump is installed on a stationary discharge connection and operates completely or partially submerged in the pumped liquid.

In addition to the pump, the following items are required:

#### Guide bars

**Guide bracket** for attaching the guide equipment to the upper part of the sump.

**Level sensors or other control equipment** for start, stop and alarm.

**Cable holder** for holding the cable and regulating the height of the level sensors.

**Discharge connection** for connecting the pump to the discharge line. The discharge connection has a flange which fits the pump housing flange and the pump housing has a bracket for attaching the guide equipment.

**Bushings** for vibration damping between the guide bars and the discharge connection.

### CP/DP/BP installation

All dimensions are in mm (in).

Provide a barrier around the pump pit, for example a guard rail.

Arrange for a cable between the sump and the electric control box. Make sure that the cables are not sharply bent or pinched.

**NOTE!** The end of the cable must not be submerged. Leads have to be above flood level, as water may penetrate through the cable into the junction box or the motor.

Grout the anchor bolts in place.

See dimensional drawing.

Place the discharge connection in position and tighten it.

Secure the guide equipment in the brackets.

Check that the guide equipment is placed vertically by using a level or a plumb line.

Connect the discharge pipe to the discharge connection.

Bolt the cable holder. Thread the level regulator cables through the holes in the cable holder and adjust the height of the sensors.

Special rules apply to installation in explosive atmosphere. Intrinsically safe circuits are normally required (Ex i).

It is recommended that the level regulators be used with low voltage. The data sheet delivered with the regulators gives the permissible voltage. Local rules may specify otherwise.

Protect bolts and nuts with corrosion preventive compound.

Lower the pump along the guide bars.

On reaching its bottom position, the pump will automatically connect to the discharge connection.

Fasten the lifting chain and the cables on the cable holder. Make sure that the cables cannot be sucked into the inlet of the pump. Support straps are required for deep installations.

Run the cables up to the electric control box.

Clean out debris from the sump before starting up the station.

The pump can be hoisted up along the guide equipment for inspection without any connections having to be undone.

### CS/DS/BS version

In the CS/DS/BS version, the pump is transportable and intended to operate completely or partially submerged in the pumped liquid.

The pump is equipped with a connection for hose, see "Parts list".

The MT-pump stands on a base stand, which is part of the pump housing. For the HT-pump, a ring works as the base stand.

### CS/DS/BS installation

Run the cables so that they have no sharp bends, are not pinched and cannot be sucked into the pump inlet. Connect the discharge line and the motor cable. See "Electrical connections".

Lower the pump into the sump.

Place the pump on a base which prevents it from sinking into a soft sump bottom.

Alternatively, the pump can be suspended from above by its handle above the bottom of the sump.

# INSTALLATION DIMENSIONS

Dimensions in mm (in).

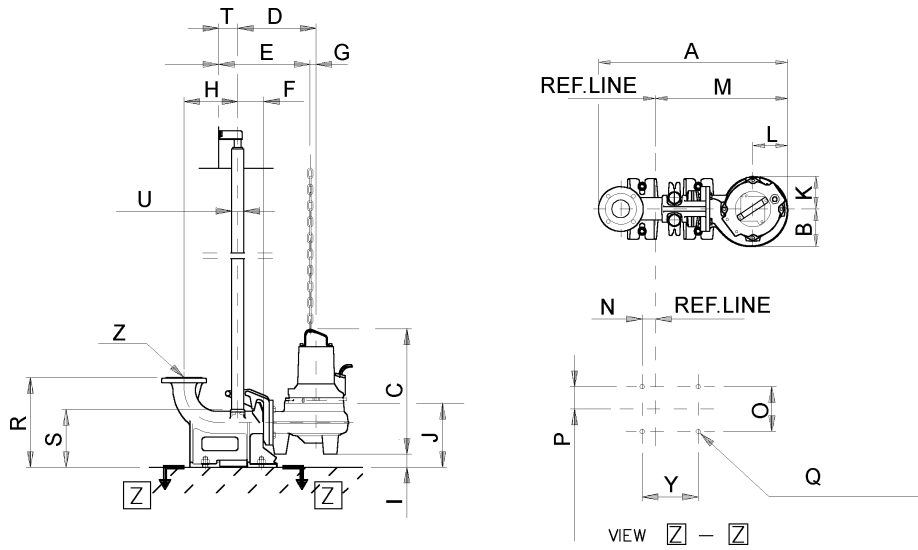

<b>CP/DP:</b>	A = 845 (33.3)	G = 26 (1.0)	M = 591 (23.3)	S = 260 (10.2)
	B = 168 (6.6)	H = 239 (9.4)	N = 59 (2.3)	T = 85 (3.3)
	C = 565 (22.2)	I = 61 (2.4)	O = 200 (7.9)	U = 2" GUIDE BARS
	D = 350 (13.8)	J = 285 (11.2)	P = 100 (3.9)	Y = 250 (9.8)
	E = 409 (16.1)	K = 146 (5.7)	Q = Ø20 (4X)	Z = DN 80
	F = 116 (4.6)	L = 156 (6.1)	R = 400 (15.7)	

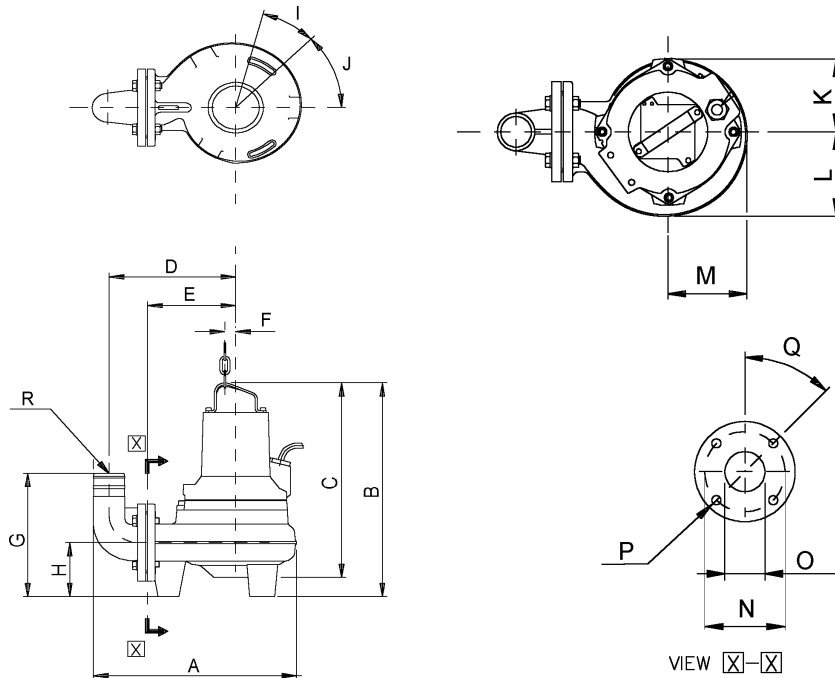

<b>CS/DS:</b>	A = 484 (19.1)	F = 26 (1.0)	K = 146 (5.7)	P = Ø 18 (4X) (0.7)
	B = 557 (21.9)	G = 321 (12.6)	L = 168 (6.6)	Q = 45°
	C = 507 (20.0)	H = 141 (5.5)	M = 156 (6.1)	R = HOSE SIZE Ø75 (2.9)
	D = 301 (11.8)	I = 30° (3X)	N = Ø152.4 (6.0)	
	E = 210 (8.3)	J = 45°	O = Ø 80 (3.1)	

# INSTALLATION DIMENSIONS

Dimensions in mm (in).

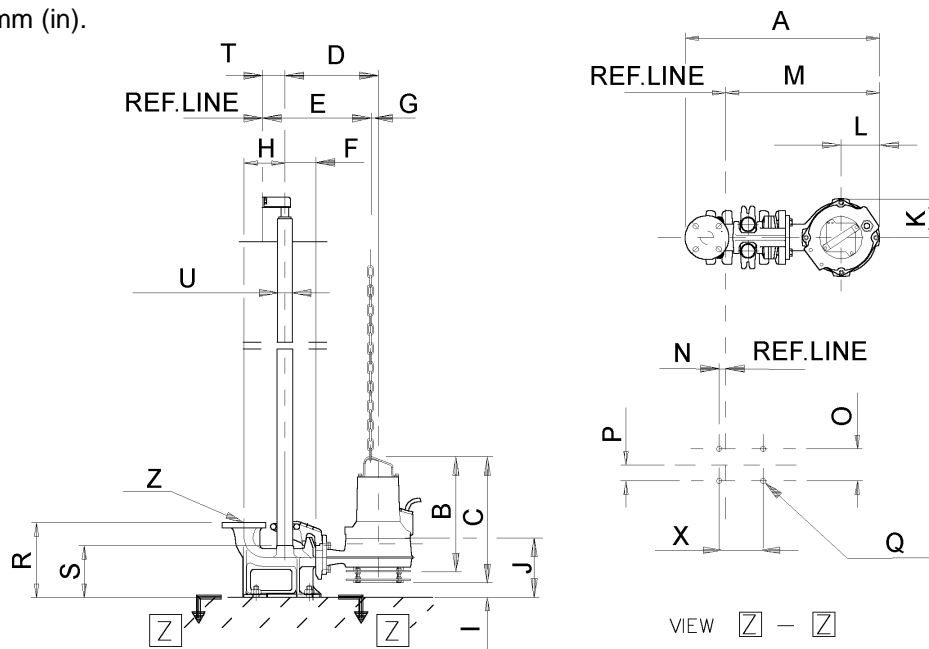

<b>BP:</b>	A = 731 (28.8)	G = 26 (1.0)	M = 580 (22.8)	S = 193 (7.6)
	B = 433 (17.0)	H = 154 (6.1)	N = 24 (0.9)	T = 85 (3.3)
	C = 473 (18.6)	I = 53 (2.1)	O = 120 (4.7)	U = 2" GUIDE BARS
	D = 350 (13.8)	J = 223 (8.8)	P = 60 (2.4)	X = 200 (7.9)
	E = 409 (16.1)	K = 146 (5.7)	Q = BOLT Ø20 (0.8) (4X)	Z = DN 50
	F = 116 (4.6)	L = 146 (5.7)	R = 280 (11.0)	

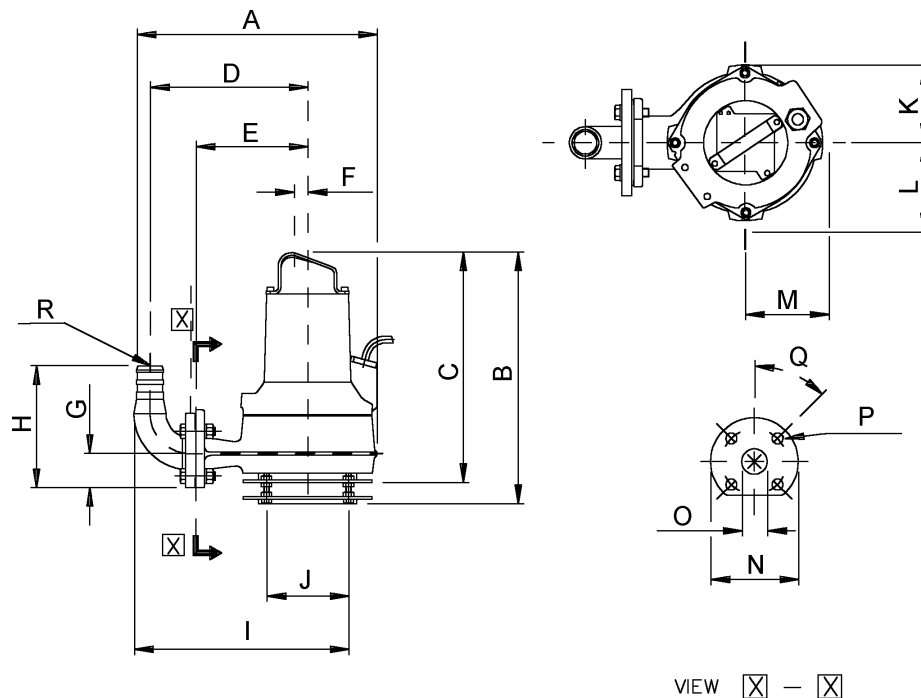

<b>BS:</b>	A = 451 (17.7)	F = 26 (1.0)	K = 146 (5.7)	P = Ø 20.5 (0.8) (4X)
	B = 473 (18.6)	G = 64 (2.5)	L = 168 (6.6)	Q = 45°
	C = 433 (17.0)	H = 229 (9.0)	M = 156 (6.1)	R = HOSE SIZE Ø50 (2.0)
	D = 296 (11.6)	I = 403 (15.9)	N = Ø165 (6.5)	
	E = 210 (8.3)	J = 154 (6.1)	O = Ø48 (1.9)	

# ELECTRICAL CONNECTIONS

All electrical work shall be carried out under the supervision of an authorized electrician.

Local codes and regulations shall be complied with.

## **WARNING!**

**All electrical equipment must be earthed. This applies to both pump equipment and any monitoring equipment.**

**Failure to heed this warning may cause a lethal accident. Make sure that the earth lead is correctly connected by testing it.**

## **NOTE for Ex version**

**All work on the explosion-proof motor section must be performed by authorized Flygt personnel or personnel authorized by Flygt.**

Check that the mains voltage and frequency agree with the specifications on the pump data plate.

The motor can be connected for different voltages as shown on the data plate.

Under no circumstances may the starter equipment be installed in the pump pit.

Install the motor cable as illustrated in the figures page 15.

To avoid leakage into the pump, check:

- that the cable entry seal sleeve and washers conform to the outside diameter of the cable. See the parts list.
- that the outer jacket on the cable is not damaged. When refitting a cable which has been used before, **always** cut off a short piece of the cable so that the cable entry seal sleeve does not close around the cable at the same point again.

NOTE! For safety reasons, the earth lead should be approx. 50 mm (2.0") longer than the phase leads. If the motor cable is jerked loose by mistake, the earth lead should be the last lead to come loose from its terminal. This applies to both ends of the cable.

Check on the data plate which connection, Y or  $\Delta$ , is valid for the voltage supply.

Three thermal switches are incorporated in the stator. The thermal switches open at 125°C (260°F). The thermal switches can be connected to max 250 V, breaking current max 4 A. Flygt recommends that they be connected to 24 V over separate fuses to protect the other automatic equipment.

Tighten the the gland nut (26) so that the cable entry unit bottoms out.

Make sure that the pump is correctly earthed (grounded).

Connect the motor cable to the starter equipment. Check the direction of rotation, see "Before starting".

If the direction of rotation is wrong, transpose two of the phase leads.

Remember that the starting surge with the direct-on-line start can be up to six times higher than the rated current. Make sure that the fuses or circuit breakers are of the proper amperage.

The table gives rated current and starting current.

Fuse amperage and cable shall be selected in accordance with local rules and regulations. Note that with long cables, the voltage drop in the cable must be taken into consideration, since the motor's rated voltage is the voltage that is measured at the terminal board in the pump.

The overload protection (motor protection breaker) shall, for direct-on-line start be set to the motor's rated current as given on the data plate.

Check the phase sequence in the mains with the phase sequence indicator.

## **Wall stuffing box**

A gastight cable entry unit in the form of a wall stuffing box shall be cast into the shaft wall or shaft roof when:

- the motor and control cables are run directly from the pump (without ground contact) to a space outside of the explosion risk area.
- non-gastight cast-in ground cables are run through a protect pipe underground to an electric control box.

## **Cable splices**

If the motor and control cables are to be lengthened, they shall be spliced with the type of cast resin or shrinking sleeves permitted for explosive areas and with explosive-proof connecting boxes. (Follow the manufacturer's instructions for this equipment.)

### Stator connection

The stator leads are colour-marked as follows:

U1	(S1)	—	red
V1	(S2)	—	brown
W1	(S3)	—	yellow
U2	(S4)	—	green
V2	(S5)	—	blue
W2	(S6)	—	black
U5	(S7)	—	red
V5	(S8)	—	brown
W5	(S9)	—	yellow
U6	(S10)	—	green
V6	(S11)	—	blue
W6	(S12)	—	black

The stator leads are connected to the cable lugs as illustrated in the figure.

**Leads not in use must be isolated.**

### Motor cable

SUBCAB 7x2.5	Yellow/green (earth), 6 black leads marked 1—6.
SUBCAB 14 AWG/7	Yellow/green (earth), black, white, red main leads, blue, orange control leads, yellow groundcheck.
SUBCAB 4x2.5 + 2x1.5	Brown, blue, black main leads. Yellow/green (earth). Control leads black marked T1, T2.

#### **NOTE for Ex version**

**All work on the explosion-proof motor section must be performed by authorized Flygt personnel or personnel authorized by Flygt. Flygt renounces all responsibility for work done by untrained, unauthorized personnel.**

6 lead stator

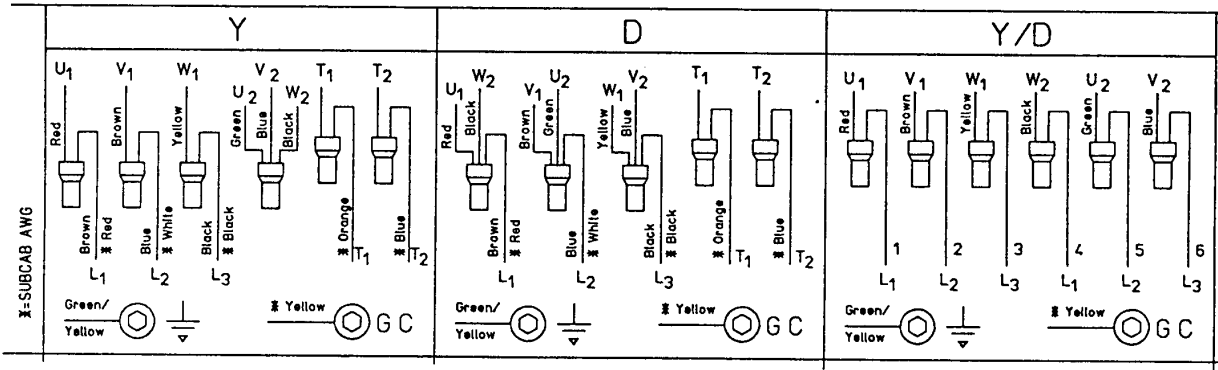

12 lead stator

Y ser.

60 Hz 440 V

460 V

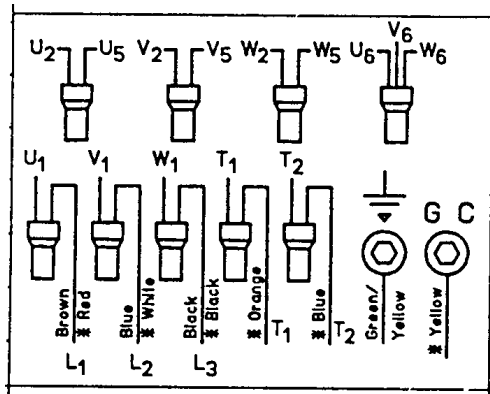

12 lead stator

Y //

60 Hz 220 V

230 V

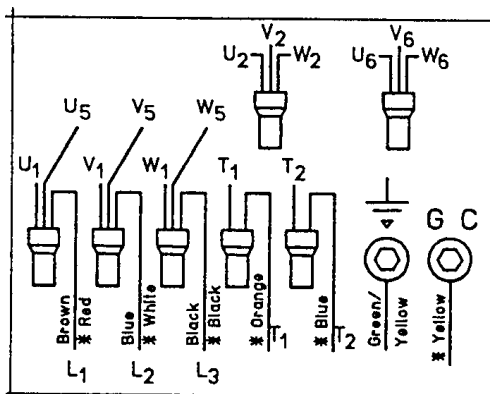



# OPERATION

## Before starting

Check the oil level in the oil housing.

Remove the fuses or open the circuit breaker and check that the impeller can be rotated by hand.

Check the direction of rotation. The impeller shall rotate clockwise, as viewed from above. When started, the pump will jerk in the opposite direction to the direction in which the impeller rotates. See the figure.

**WARNING! Watch out for the starting jerk, which can be powerful.**

## Leakage sensor FLS (built-in version)

The pump is available with leakage sensor for sensing water in the stator housing.

A plate in the junction box shows that the pump is equipped with sensor.

The FLS sensor consists of a small float switch for sensing water the stator housing. Its design makes it suitable for pumps in vertical installations.

The FLS sensor is installed in the bottom of the stator housing (k).

It is connected on installation to an alarm relay, type Mini CAS, in accordance with the diagram page 17.

**IMPORTANT!** Be careful when removing the pump's motor unit not to damage the leads. (Disconnect the leads before the rotor assembly and the stator housing are separately completely). Also be careful not to damage the sensors.

Make sure that the leads are not pinched during assembly.

## Starting jerk

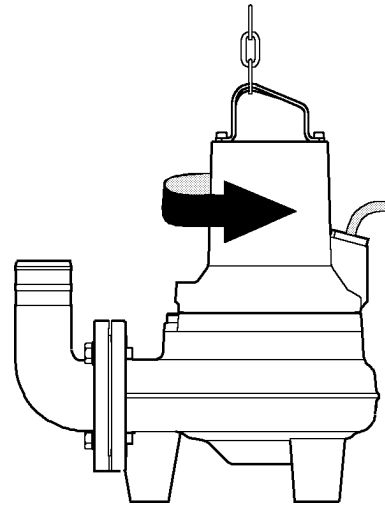

FLS

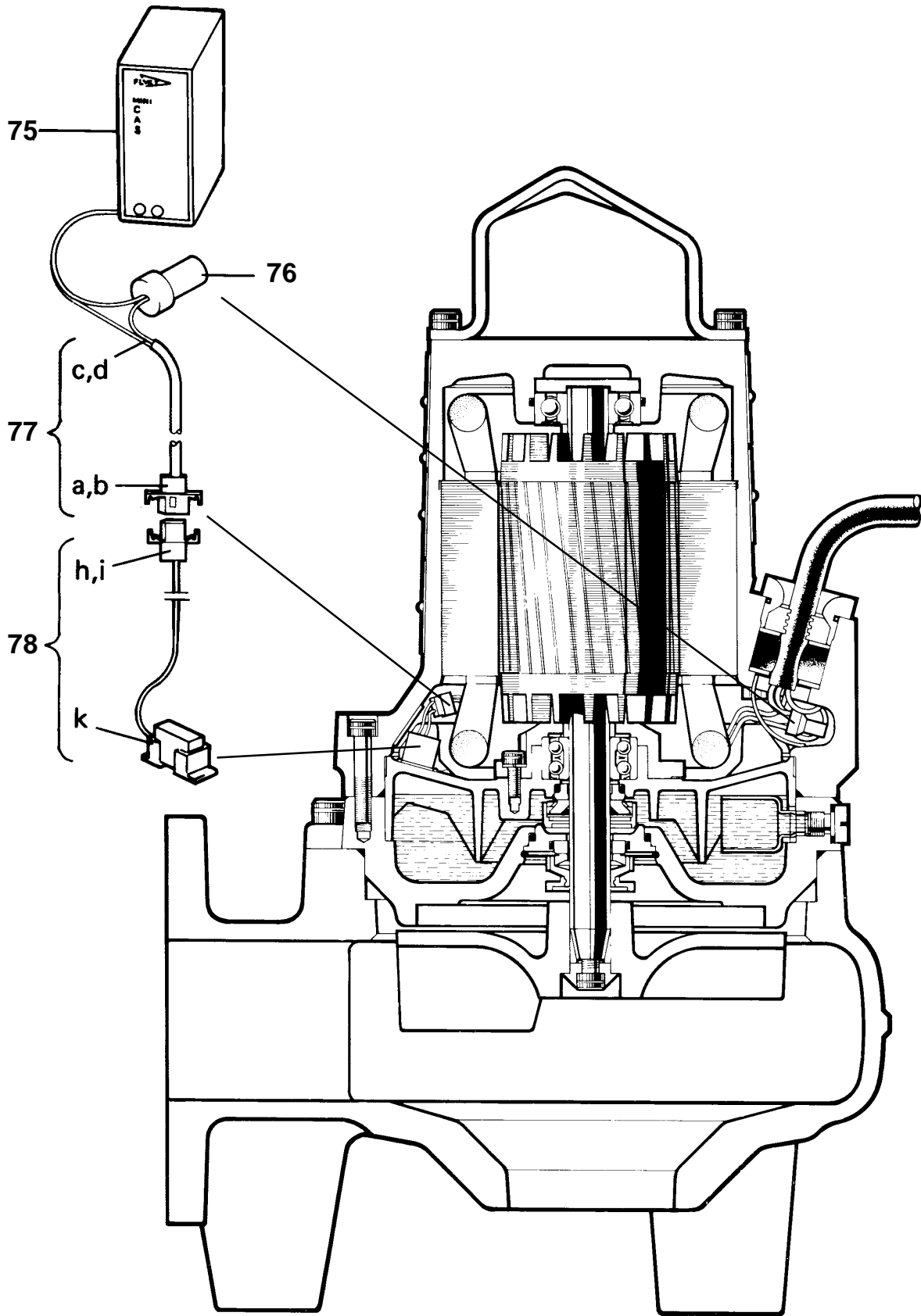

# CARE AND MAINTENANCE

The figures in parentheses are item numbers and refer to the cutaway figures.

## Safety precautions

### **WARNING!**

**Before starting work on the pump, make sure that the pump is isolated from the power supply and cannot be energized.**

The following points are important in connection with work on the pump:

- make sure that the pump has been thoroughly cleaned.
- observe good personal hygiene.
- beware the risk of infection.
- follow local safety regulations.

The pump is designed for use in liquids which can be hazardous to health. In order to prevent injury to the eyes and skin, observe the following points when working on the pump:

- Always wear goggles and rubber gloves.
- Rinse the pump thoroughly with clean water before starting work.
- Rinse the components in water after disassembly.
- Hold a rag over the oil housing screw when removing it. Otherwise, pressure that may have built up in the pump due to the leakage of pumped liquid into the pump may cause splatter into the eyes or onto skin.

Proceed as follows if you get hazardous chemicals in your eyes:

- Rinse immediately in running water for 15 minutes. Hold your eyelids apart with your fingers.
- Contact an eye doctor.

On your skin:

- Remove contaminated clothes.
- Wash skin with soap and water.
- Seek medical attention if required.

### **NOTE for Ex version**

**All work on the explosion-proof motor section must be performed by authorized Flygt personnel or personnel authorized by Flygt.**

**Flygt renounces all responsibility for work done by untrained, unauthorized personnel.**

## Inspection

Regular inspection and preventive maintenance ensure more reliable operation.

The pump should be inspected after 2000 hours of operation or at least once a year, more frequently under severe operating conditions.

Under normal operating conditions, the pump should have a major overhaul in a service shop after 6000 hours of operation or at least every third year for CP/BP/DP, every year for CS/BS/DS.

This requires special tools and should be done by an authorized service shop.

When the pump is new or when the seals have been replaced, inspection is recommended after one week of operation.

### **Service contract**

Flygt or its agent offers service agreements in accordance with a preventive maintenance plan. For further information, please contact your Flygt representative.

## Recommended inspections:

Inspection of	Action
Visible parts on pump and installation	<p>Replace or fix worn and damaged parts.</p> <p>Make sure that all screws, bolts and nuts are tight.</p> <p>Check the condition of lifting handle/lifting eyes, chains and wire ropes.</p> <p>Check that the guide bars are vertical.</p>
Pump housing and impeller	<p>Replace worn parts if they impair function.</p> <p>If the clearance between the impeller neck and the pump housing exceeds 2 mm (0.08 in), see "Replacing the wear ring".</p> <p>Wear on the impeller and the parts around it necessitates fine adjustment of the impeller or replacement of worn parts. See "Replacing the impeller".</p>
Oil quantity	<p>WARNING. If the seal leaks, the oil housing may be under pressure. Hold a rag over the oil housing screw in order to prevent splatter. See "Safety precautions" for additional information.</p> <p>Check that the oil reaches up to the oil hole when the pump is tilted about 18°.</p> <p>Add oil as needed. See "Changing the oil".</p>
Condition of the oil	<p>A check of the condition of the oil can show whether there has been an increased leakage. Note! Air/oil mixture can be confused with water/oil mixture.</p> <p>Insert a tube (or hose) into the oil hole. Cover the top end of the tube and take up a little oil from the bottom.</p> <p>Change the oil if it contains too much water, i.e., is heavily emulsified (cream-like), or if the oil housing contains separated water. See "Changing the oil". Check again one week after changing the oil.</p> <p>If the oil contains too much water again, the fault may be:</p> <ul style="list-style-type: none"> <li>— that an oil screw (22) is not sufficiently tight.</li> <li>— that an O-ring (10) or its sealing surface is damaged.</li> <li>— that the outer mechanical seal (33) is damaged.</li> </ul> <p>Contact a Flygt service shop.</p>
Liquid in the stator housing	<p>WARNING. If there has been leakage, the stator housing may be under pressure . See "Safety precautions" for additional information.</p> <p>If there is water in the stator housing, the cause may be:</p> <ul style="list-style-type: none"> <li>— that an O-ring (13) is damaged.</li> <li>— that the cable entry is leaking.</li> </ul> <p>If there is oil in the stator housing, the cause may be:</p> <ul style="list-style-type: none"> <li>— that the inner mechanical seal (34) is damaged.</li> </ul> <p>Contact a Flygt service shop.</p>
Cable entry	<p>If the cable entry leaks:</p> <ul style="list-style-type: none"> <li>— check that the entry is firmly tightened into its bottom position.</li> <li>— cut a piece of the cable off so that the seal sleeve (18) closes around a new position on the cable.</li> <li>— replace the seal sleeve (18).</li> <li>— check that the seal sleeve (18) and the washers (9) conform to the outside diameter of the cables.</li> </ul>
Cables	<p>Replace the cable if the outer jacket is damaged. Make sure that the cable do not have any sharp bends and are not pinched.</p> <p>Optionally, a metal hose can be ordered to protect the cable in aggressive environments (43).</p>

Inspection of	Action
Level sensors or other level equipment	Level sensors or other level equipment. Check function. Clean, adjust, replace or repair damaged level sensing equipment. Follow the instructions for the level sensing equipment in question. Note! Only use EX-approved equipment.
Starter equipment	If faulty, contact an electrician.
Monitoring equipment (should be checked often)	Follow the instructions for monitoring equipment. Check: — signals and tripping function. — that relays, lamps, fuses and connections are intact. Replace defective equipment. Note! Only use EX-approved equipment.
Rotation direction of pump (requires voltage)	Transpose two phase leads if the impeller does not rotate clockwise as viewed from above. Rotation in the wrong direction reduces the capacity of the pump and the motor may be overloaded. Check the direction of rotation, during non-load every time the pump is reconnected.
Pipes, valves and other peripheral equipment	Pipes, valves and other peripheral equipment. Repair faults and notify supervisor of any faults or defects.
Insulation resistance in the stator	Use insulation tester. With 1000 V-DC megger the insulation between the phases and between any phase and earth (ground) should be > 1 MΩ.

## Changing the oil

**WARNING.** If the seal leaks, the oil housing may be under pressure. Hold a rag over the oil plug to prevent splatter.

Lay the pump on its side on a bench or over two supports.

Unscrew the oil housing screw.

Emptying the oil must be done through the “Oil out” hole.

Turn the pump so that the oil hole faces downwards.

It is easier to drain the oil if the other oil hole screw “Oil in” is also removed.

In order to get out all the oil, the pump must be raised upright for a short while during drainage.

Replace the O-rings under the oil housing screws with new ones.

Install the “Oil out” screw and fill with oil through the other hole.

It is important that the oil be added through the hole marked “Oil in” since the oil housing must contain some air for pressure equalization.

The pump should be slightly tilted and put down again horizontally in order to get the full amount of oil in.

Fill up with 0.8 litres (0.8 US quarts) of new oil. Use an ordinary SAE 10W-30 motor oil.

Always replace the O-rings of the oil hole screws. Put the screws back and tighten them. Tightening torque 10 Nm (7.4 ft lb).

## Replacing the wear ring

When the clearance between the impeller neck and the pump housing exceeds 2 mm (0.08 in), the following replacement must be made.

Replacing the wear ring in the C/MT pump housing (84).

Disconnect and lift off the motor section from the pump housing.

Remove the wear ring (84).

Drive in the new wear ring.

Use a rubber mallet or wooden block to prevent deformation.

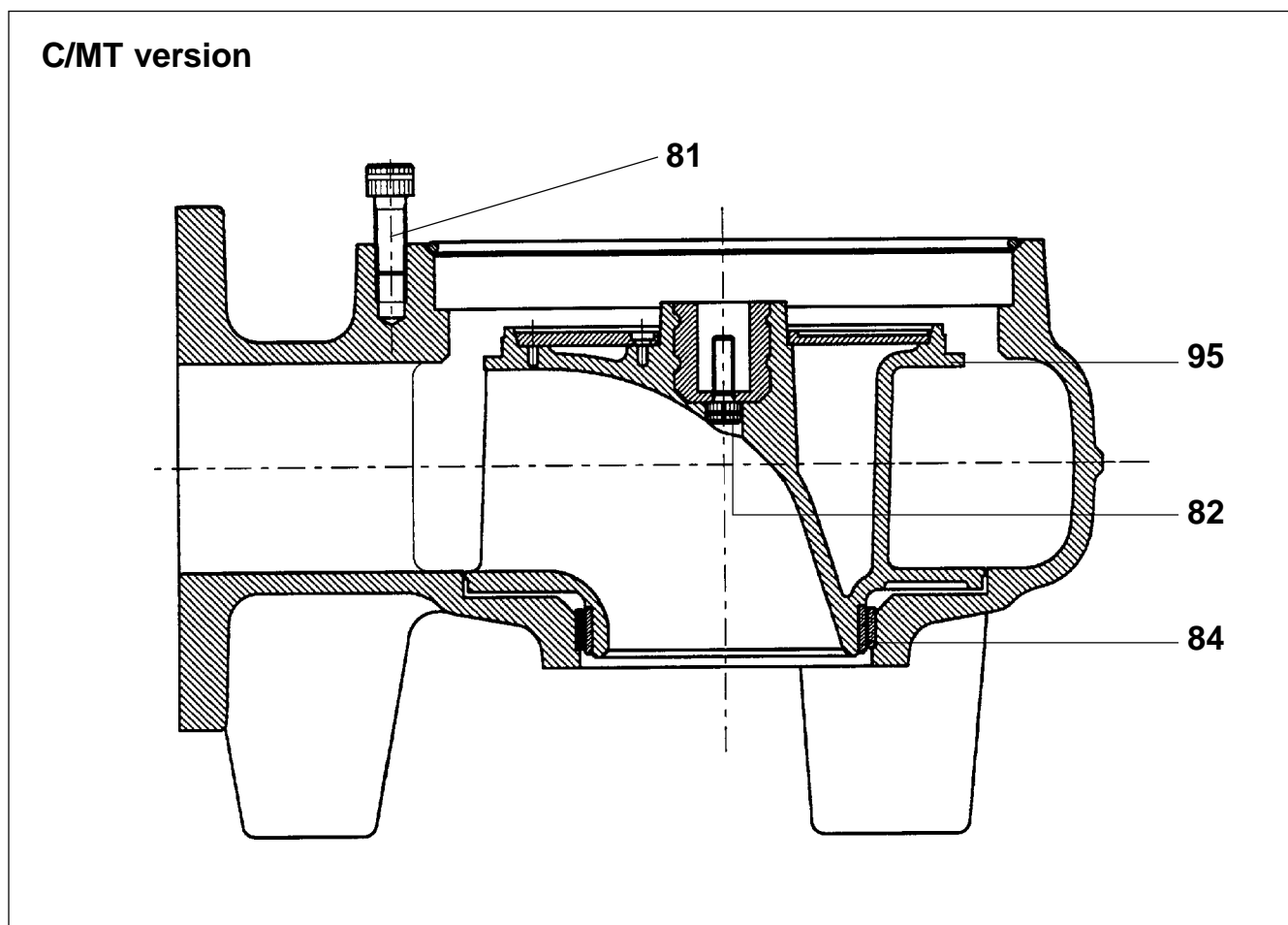

## Replacing the impeller

### Removing the impeller

WARNING! Worn impellers often have very sharp edges.

Remove bolts (81) and lift the motor section off of the pump housing.

Lay the motor section on its side.

Remove impeller screw (82).

Pull off the impeller (95).

Do not pry off the impeller, since it can easily be damaged.

### Installing the impeller

Make sure that the end of the shaft is clean and free of burrs.

Polish off any flaws with fine emery cloth.

Check:

— that the conical sleeve (42, cutaway view last page) is seated in the impeller hub.

Press the impeller onto the shaft with the impeller screw.

Note the following points when installing the impeller:

The D/MT-impeller has a separate washer (85) and the B/HT-impeller has a separate sleeve (86) under the impeller screw. The C/MT-impeller has no separate sleeve/washer.

Tighten the impeller screw (82).

Tightening torque 34 Nm (25 ft lb).

Check that the impeller can be rotated by hand.

Fit the motor section to the pump housing. Make sure that the pump housing has the right orientation. Tightening torque of MT-screws (81) 57 Nm (42 ft lb) and HT-screws (99, cutaway view last page) 17 Nm (12.5 ft lb).

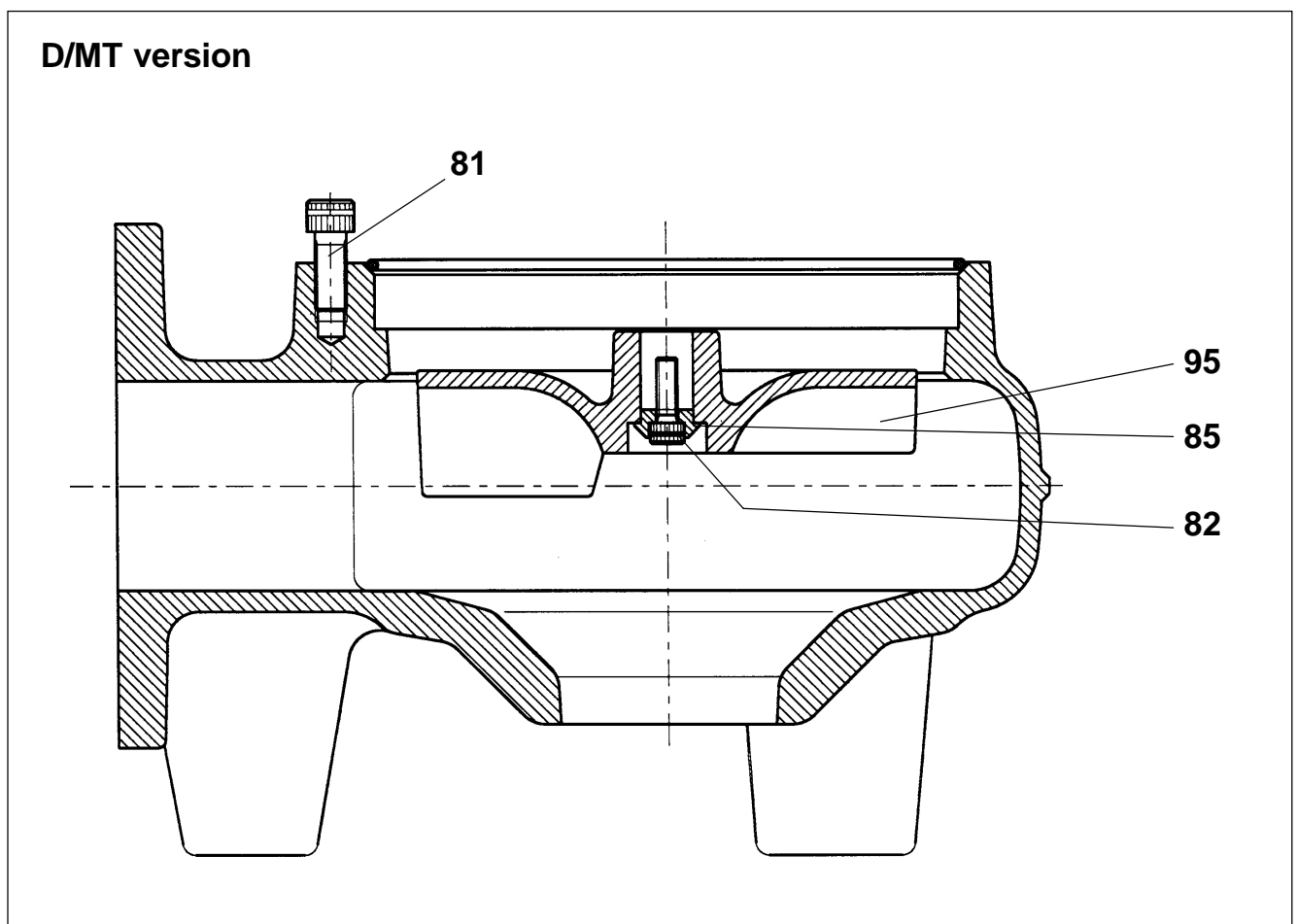

### Adjusting the HT-impeller

Screw the adjusting nuts (88) down toward the bottom of the studs (87).

Press the suction cover (90) against the impeller.

Screw the adjusting nuts (88) so that they lie flush against the suction cover (90).

Back off all adjusting nuts another half-turn (counter-clockwise).

The clearance between the impeller (95) and the suction cover (90) shall be approximately 0.5 mm (0.02 in).

Check that the impeller can easily be rotated by hand.

In order for the pump to perform at maximum capacity, the impeller must be adjusted regularly.

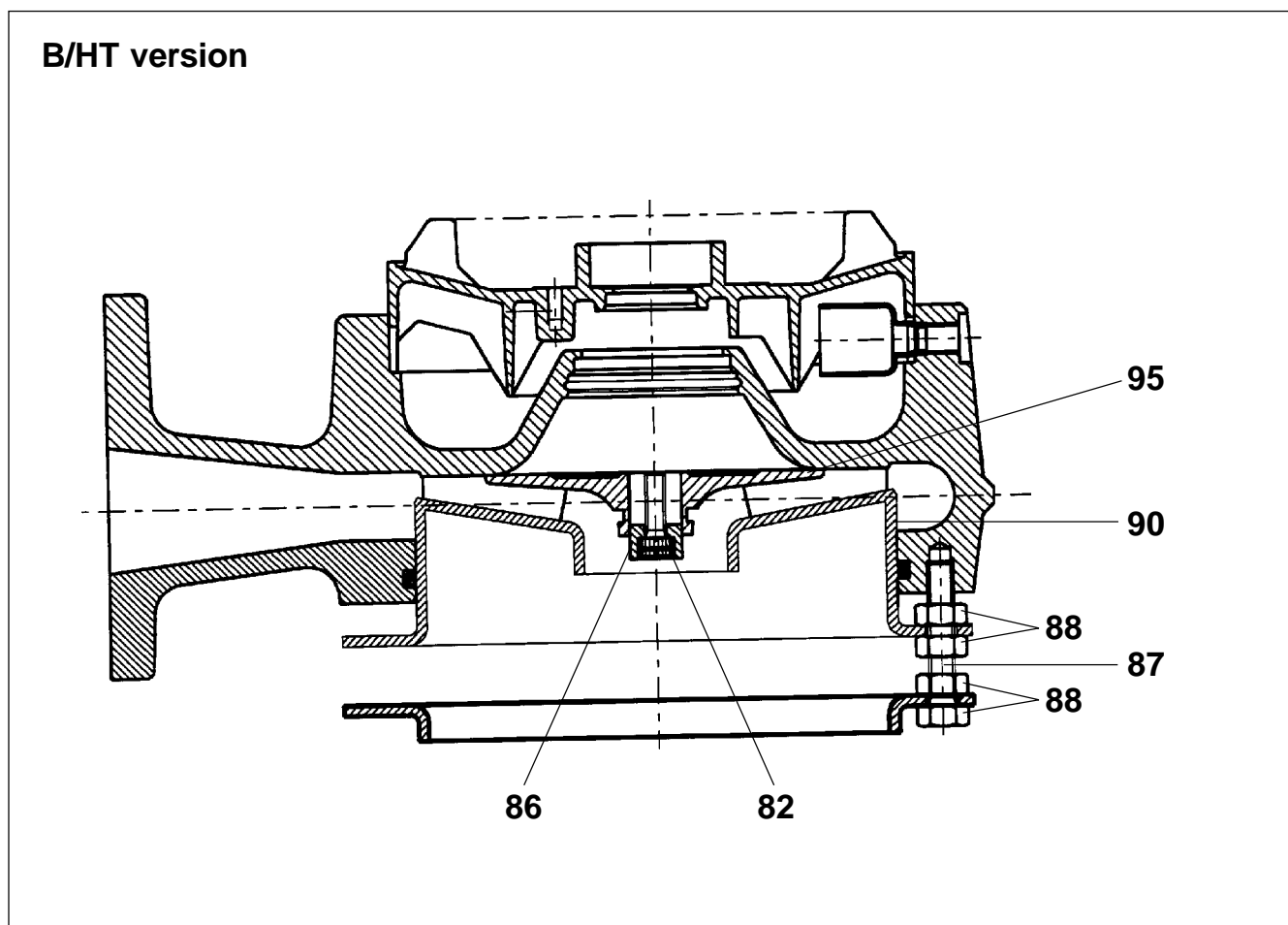



# FAULT TRACING (TROUBLESHOOTING)

A universal instrument (VOM), a test lamp (continuity tester) and a wiring diagram are required in order to carry out fault tracing on the electrical equipment.

Fault tracing shall be done with the power supply disconnected and locked off, except for those checks which cannot be performed without voltage.

Always make sure that there is no one near the pump when the power supply is turned on.

Use the following checklist as an aid to fault tracing. It is assumed that the pump and installation have formerly functioned satisfactorily.

Electrical work shall be performed by an authorized electrician.

Follow local safety regulations and observe recommended safety precautions.

## 1. Pump fails to start

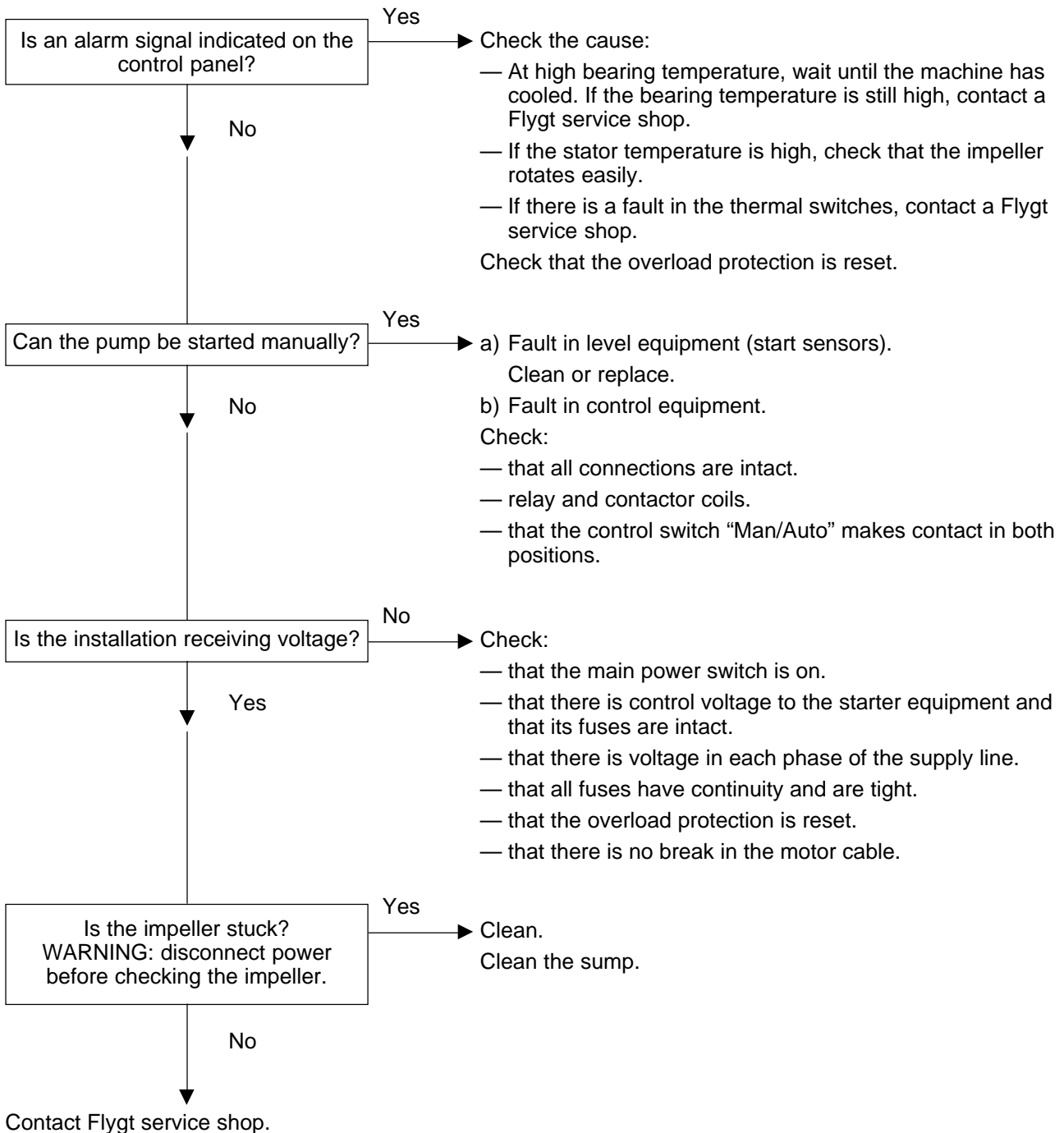

## 2. Pump starts but motor protection trips

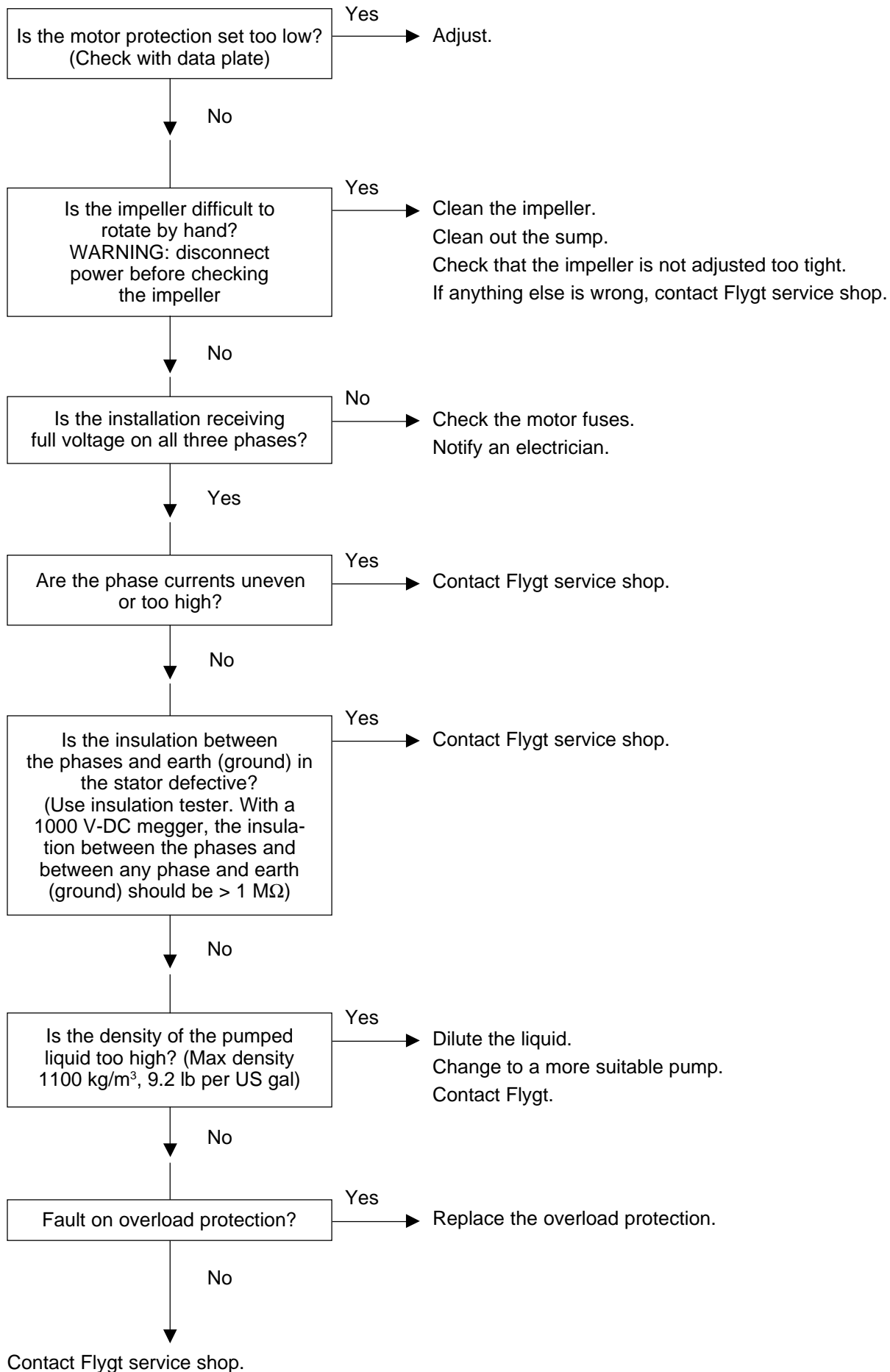

### 3. The pump does not stop (when level control is used)

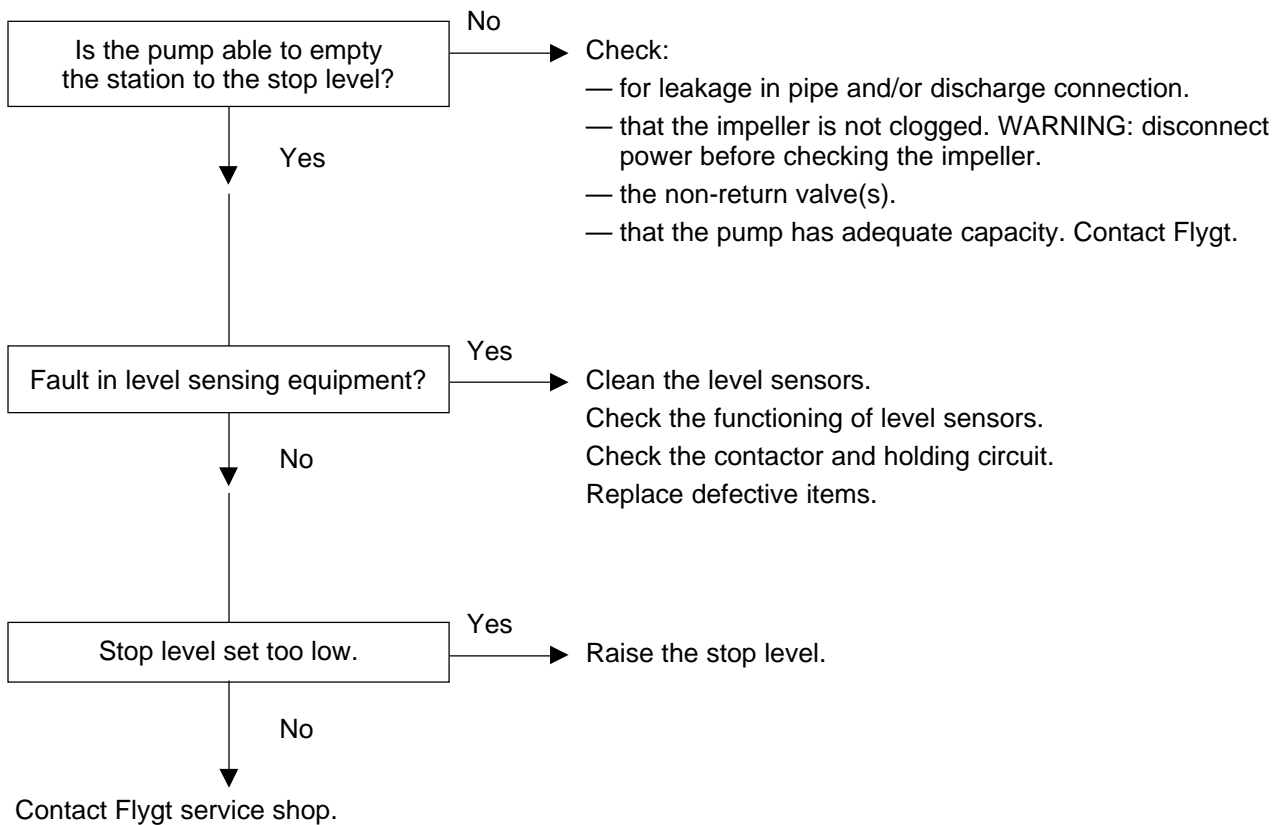

### 4. The pump starts-stops-starts in rapid sequence

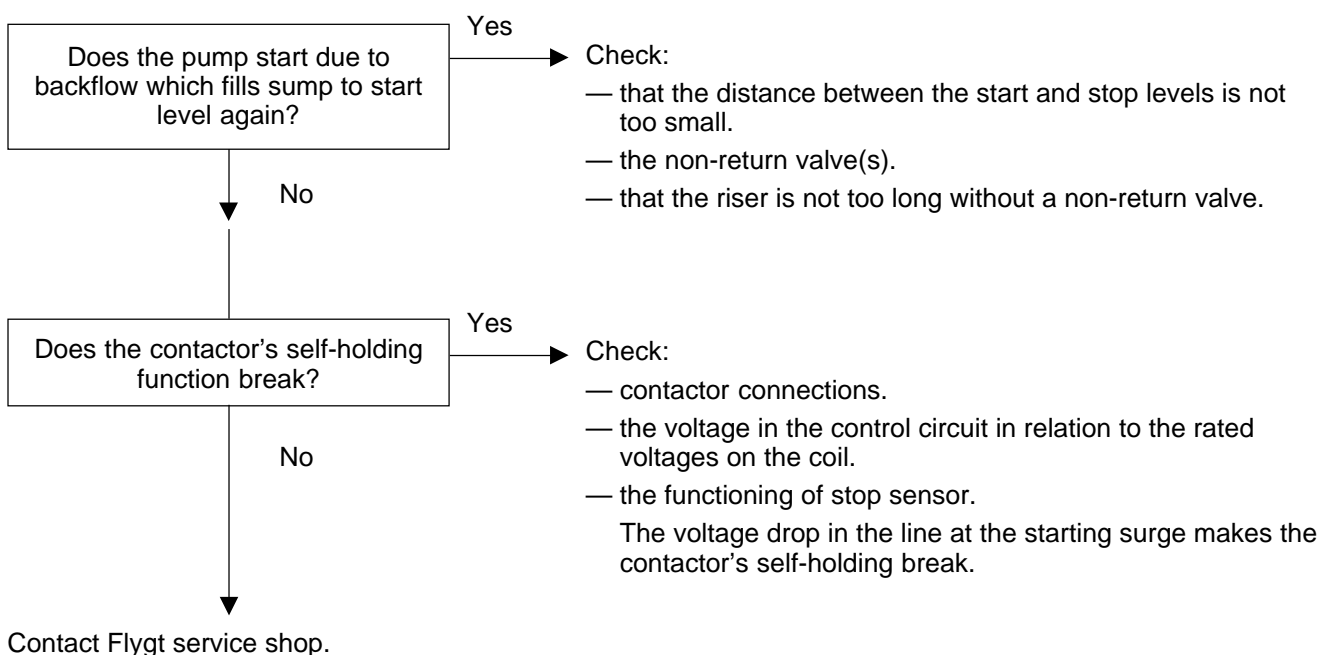

## **5. Pump runs but delivers too little or no water**

Check:

- direction of rotation of pump, see “Before starting”.
- that valves are open and intact.
- that pipes, impeller and strainer are not clogged.
- that the impeller rotates easily.
- that the suction lift has not been altered.
- for wear on wear ring, impeller, pump housing/flange, suction bottom, diffuser disc, diffuser.

See also under “Inspection”.

**Do not override the motor protection repeatedly if it has tripped.**

# ACCESSORIES AND TOOLS

## Zinc anode set

Not applicable for the stainless steel version.

## Level sensor

Flygt supplies level sensors suited for different liquid densities and with different cable lengths. See separate brochure.

Special rules apply to installation in an explosive atmosphere. Intrinsically safe circuits are normally required (EX i).

## Start and control equipment

Flygt has suitable start and control equipment for the pump.

Contact Flygt for further information.

Note! Only use EX-approved equipment.

## Tools

Besides ordinary standard tools, the following tools are required in order to perform the necessary care and maintenance of the pump:

Order No.	Description
216 68 00	Sleeve puller for inner seal unit
400 29 00	Stepped heat dowel (bearing heater)
403 90 00	Stator puller unit
407 99 00	Mandrel for knocking the oil housing apart
426 34 00	Mounting socket for seal unit
463 78 02	Mounting tool for seal unit
84 15 66	Torque wrench 0—137 Nm

For further information on tools, see Flygt's Tool Catalogue.

# SERVICE LOG

Most recent service date	Pump No.	Hours of operation	Remarks	Sign.

3085.290

