

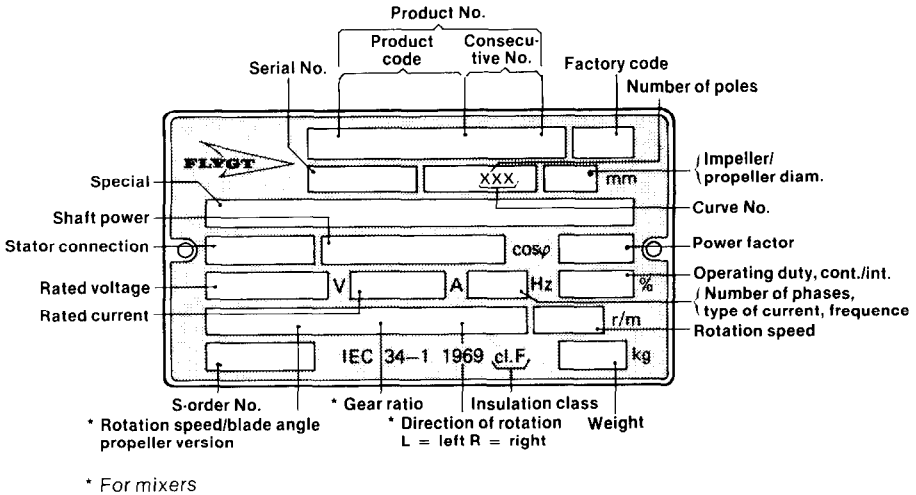

# Care and maintenance



# DATA PLATE INTERPRETATION



Flygt undertakes to remedy faults in products sold by Flygt provided:

- that the fault is due to defects in design, materials or workmanship;
- that the fault is reported to Flygt or Flygt's representative during the guarantee period;
- that the product is used only under conditions described in the care and maintenance instructions and in applications for which it is intended;
- that the monitoring equipment incorporated in the product is correctly connected;
- that all service and repair work is done by a workshop authorized by Flygt;
- that genuine Flygt parts are used.

Hence, the guarantee does not cover faults caused by deficient maintenance, improper installation, incorrectly executed repair work or normal wear and tear.

Flygt assumes no liability for either bodily injuries, material damages or economic losses beyond what is stated above.

Flygt guarantees that a spare parts stock will be kept for 15 years after the manufacture of this product has been discontinued.

The manufacturer reserves the right to alter performance, specification or design without notice.

## CONTENTS

<b>Technical data</b> .....	4
<b>Installation</b> .....	4
<b>Electrical connections</b> .....	5
<b>Motor protection</b> .....	5
<b>Care and maintenance</b> .....	6
<b>Inspection</b> .....	6
<b>Oilcheck</b> .....	6
<b>Operation</b> .....	7
<b>Accessories and tools</b> .....	7
<b>Fault tracing (Troubleshooting)</b> .....	7
<b>Part list</b> .....	8
<b>Service log</b> .....	10

## Technical particulars

The GP 3033 is an electric submersible centrifugal pump, intended for ground water pumping.

**Motor:** 3-phase a.c. motor developing 0.22 kW 0.3 hp at 2700 rpm.

**Rated current:** 220V: 1.2A; 380V: 0.7 A; 400/415 V: 0.65 A; 440 V: 0.6 A.

**Power cable:** According to specification.

**Discharge connection:** Nom.conn. no. 32 (BSP 1 1/4").

**Weight, complete:** 22 kg (48 lb).

## INSTALLATION

Clean the sump thoroughly before installing the pump.

The same pump can be used for varying depths of sump. Fit a cut length of galvanised steel pipe, threaded or flanged to suit sump dimensions, to the pump discharge. Lower the pump into the chamber and connect the pipe to the rising main. A sluice valve should be fitted into the pipework.

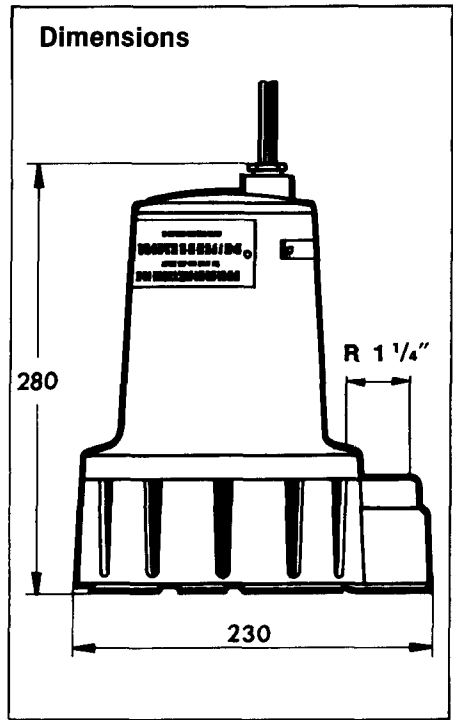

## Capacity

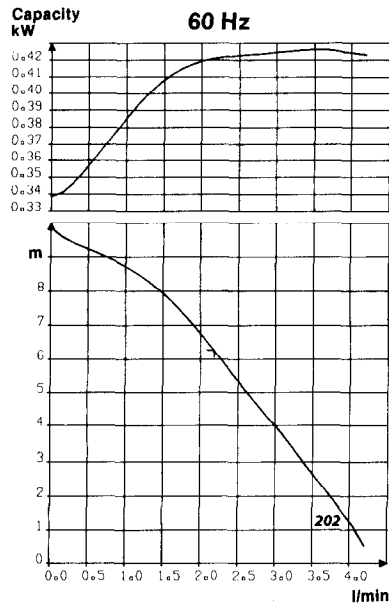
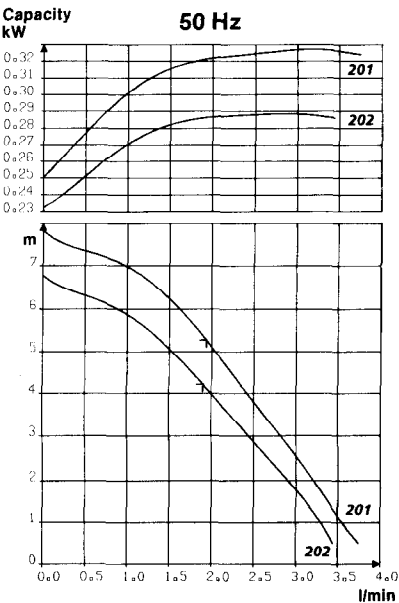

## Electrical connections

**Isolate the power supply before working on the pump.**

All electrical work shall be carried out under the supervision of an authorized electrician.

Local codes and regulations shall be complied with.

The motor is intended for 3-phase AC supply and can be arranged for various voltages.

Check on the data plate which connection, Y or  $\Delta$ , is valid for the voltage supply. Then, depending on voltage, arrange the connection on the terminal board in accordance with Y or  $\Delta$ . See fig.

The stator leads are connected to the terminal board as follows:

Stator lead	Connection on terminal board
U1, red	U1 (S1)
V1, brown	V1 (S2)
W1, yellow	W1 (S3)
V2, blue	V2 (S4)
W2, black	W2 (S5)
U2, green	U2 (S6)

Recommended mains fuse: 6 A.

## Motor protection

**A motor control with overcurrent protection should always be used.**

Check that it is marked and set on right current acc to data plate.

If the cutout trips during normal running check the fuses before restarting. Never by-pass a tripped cuout: find out the cause of the trouble or call your Flygt service engineer.

## Rotation

As a check on electrical connections, stand the pump slightly tilted (as in the figure) and switch on momentarily. The pump should jerk anticlockwise at

### $\Delta$ -connection

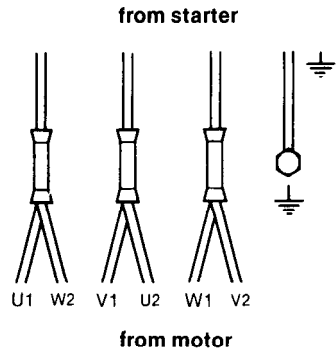

### Y-connection

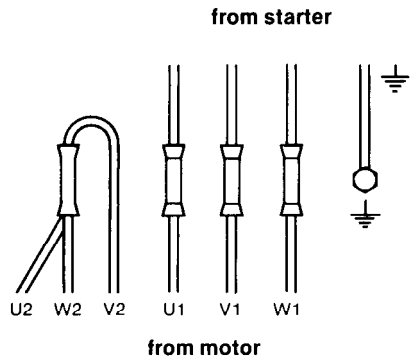

### Starting jerk

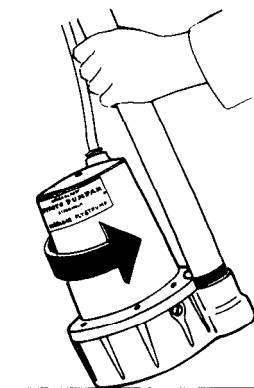

the instant of starting. If it jerks the other way, switch two phases in the motor control. Running the pump in the wrong direction of rotation means reduced capacity and strains the motor.

Always check the rotation again after failure of a single phase or a power blackout, since phases may have become switched.

## CARE AND MAINTENANCE

### Safety precautions

Before starting work on the pump, make sure that the pump is isolated from the power supply and cannot be energized.

### Inspection

During inspections check that no leakage has occurred past either of the shaft seals. The procedure for this is described below, under "Oil check". If the pump is new or the seals have recently been replaced carry out a first check after one week, if possible.

**Normally the pump should be inspected at least once a year.**

If it works in very dirty or aggressive water, inspections should be carried out more frequently.

### Oil check

Lay the pump on a workbench with the plug marked OIL uppermost. Remove this plug. Turn the pump over to allow the oil to run into a can, as shown in fig.

If about 1/10 litre (1/6 pint) of oil runs out and it looks clean the seals are in good order.

If the oil is pale yellowish grey and very sluggish, or if there are distinct droplets of water in it, change the oil. Check the oil again after one week. If water is again found in the oil, the lower seal may be defective and the pump should be dismantled for overhaul, including replacement of the lower shaft seal.

### Draining oil

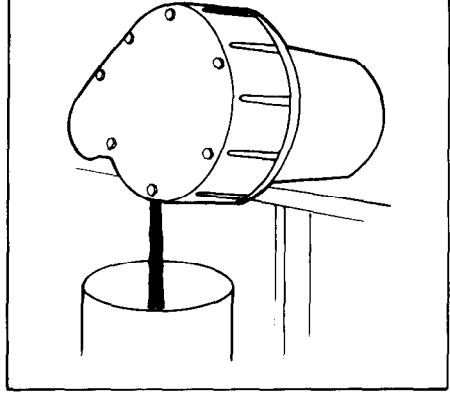

**Refill the oil casing with 1/10 litre (1/6 pint) of SAE 10W-30 oil.**

Check that the O-ring under the OIL plug is undamaged and tighten the plug securely to prevent leakage.

### Major overhaul

Mainly for the sake of the ball bearings, the pump should undergo major overhaul every three years. This involves: Complete disassembly, cleaning and inspection of all sealing surfaces. Replacement of damaged or worn parts. Cleaning and greasing of ball bearings. Replacement of lower ball bearing if water-oil mixture has penetrated the stator housing.

### Shaft seal

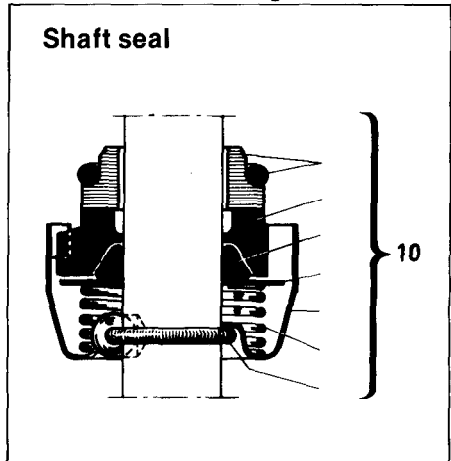

## Checking motor insulation

During a major overhaul the motor insulation should be checked. Using a 500V megger, an insulation resistance in excess of 1 megohm should be recorded. This applies both between phases and between any phase and the pump body.

## OPERATION

### Handling

Always lift the pump by its pipe, never by the motor cable.

### Cleaning

If the pump has been running in very dirty water, let it run for while in clean water, or flush it through the discharge connection. If clay, cement or other similar dirt is left in the pump it may clog the impeller and seal preventing the pump from working.

## ACCESSORIES AND TOOLS

### Level sensor

Flygt supplies level sensors suited for different liquid densities and with different cable lengths. See separate brochure.

### Start and control equipment

Flygt has suitable start and control equipment for the pump. Contact Flygt for further information.

## TOOLS

Besides ordinary standard tools, the following tools are required in order to perform the necessary care and maintenance of the pump:

Order No.	Description
398 28 00	Mounting sleeve for sealing
400 25 00	Mandrel
400 26 00	Mounting sleeve for bearing

For further information on tools, see Flygt's Tool Catalogue.

## FAULT TRACING (TROUBLESHOOTING)

A universal instrument (VOM), a test lamp (continuity tester) and a wiring diagram are required in order to carry out fault tracing on the electrical equipment.

Fault tracing shall be done with the power supply disconnected and locked off, except for those checks which cannot be performed without voltage.

Always make sure that there is no one near the pump when the power supply is turned on.

Use the following checklist as an aid to fault tracing. It is assumed that the pump and installation have formerly functioned satisfactorily.

Electrical work shall be performed by an authorized electrician.

Follow local safety regulations and observe recommended safety precautions.

## Pump fails to start

Check:

- that the main power switch is on.
- that there is control voltage to the starter equipment and that its fuses are intact.
- that there is voltage in each phase of the supply line.
- that all fuses have continuity and are tight.
- that the overload protection is reset.
- that there is no break in the motor cable.

**WARNING:** disconnect power before checking the impeller.

Contact Flygt service shop.

# Parts list

for GP 3033.020 (3-phase)

Please state pump serial number when ordering parts. Use part numbers— not item no. — for stock records and parts ordering.

Item no.	Part no.	Denomination	Quantity
1	82 40 50	Washer (10)—12 mm	2
1	82 40 52	Washer (12)—14 mm	2
2	220 25 00	Gland nut	1
3	229 80 00	Earth terminal	1
4	250 84 00	Inspection screw	1
5	253 27 00	Adjusting washer	max 4
6	275 61 00	Strainer bottom	1
7		IMPELLER	1
	275 62 06	50 Hz, Curve no. 201	
	275 62 07	50 Hz and 60 Hz, Curve no. 202	
8	275 80 02	Rubber seal	1
10	277 75 01	Shaft seal assy.	2
18	283 92 00	Washer	1
19		STATOR	1
	285 86 27	190—200VY 50 Hz	200—222VY 60 Hz
	285 86 32	346—350/ 200—208V 50 Hz	380—400/ 230—240V 60 Hz
	285 86 34	380/220V 50 Hz	440—460/260V 60 Hz
	285 86 43	400—440VY 50 Hz	480VY 60 Hz
	285 86 49	500V Y 50 Hz	
20	285 88 00	Rotor unit	1
21	94 20 41	Motor cable	8 or 20 m
	83 42 95	Cable lug	1
22	286 65 00	Pump Housing	1
23	286 66 00	Oil casing	1
24	287 67 00	Bearing housing	1
25	287 68 00	Stator housing	1
26	287 69 00	Junction box cover	1
	287 70 00	Carrying handle (supplied to special order)	
30	80 74 01	Key 2 × 2 × 8	1
31	81 51 54	Screw ¼ UNC × 13	15
32	82 51 67	Screw ¼ UNC × 89	3
33	82 35 14	Washer 6.7 × 14	1
34	82 47 55	Spring Washer 4.1	1
35	82 60 84	Circlip 12	2
36	82 61 95	Circlip 32	1
37	82 73 83	O-ring 11.3 × 2.4	1
38	82 78 15	O-ring 78.0 × 4.0	1
39	82 78 20	O-ring 90.0 × 4.0	1
40	82 74 17	O-ring 124.3 × 5.7	1
41	82 44 01	Supporting ring 12 × 18 × 1.2	1
42	83 32 41	Ball bearing SKF 6201 RS	2
43	83 44 24	Plasti-Grip	4
	90 17 51	Oil SAE 10W-30	0.1 litre
	90 20 54	Bearing grease, BP Energrease LS3 or Shell Alvania Grease 3	as reqd.



3033.020

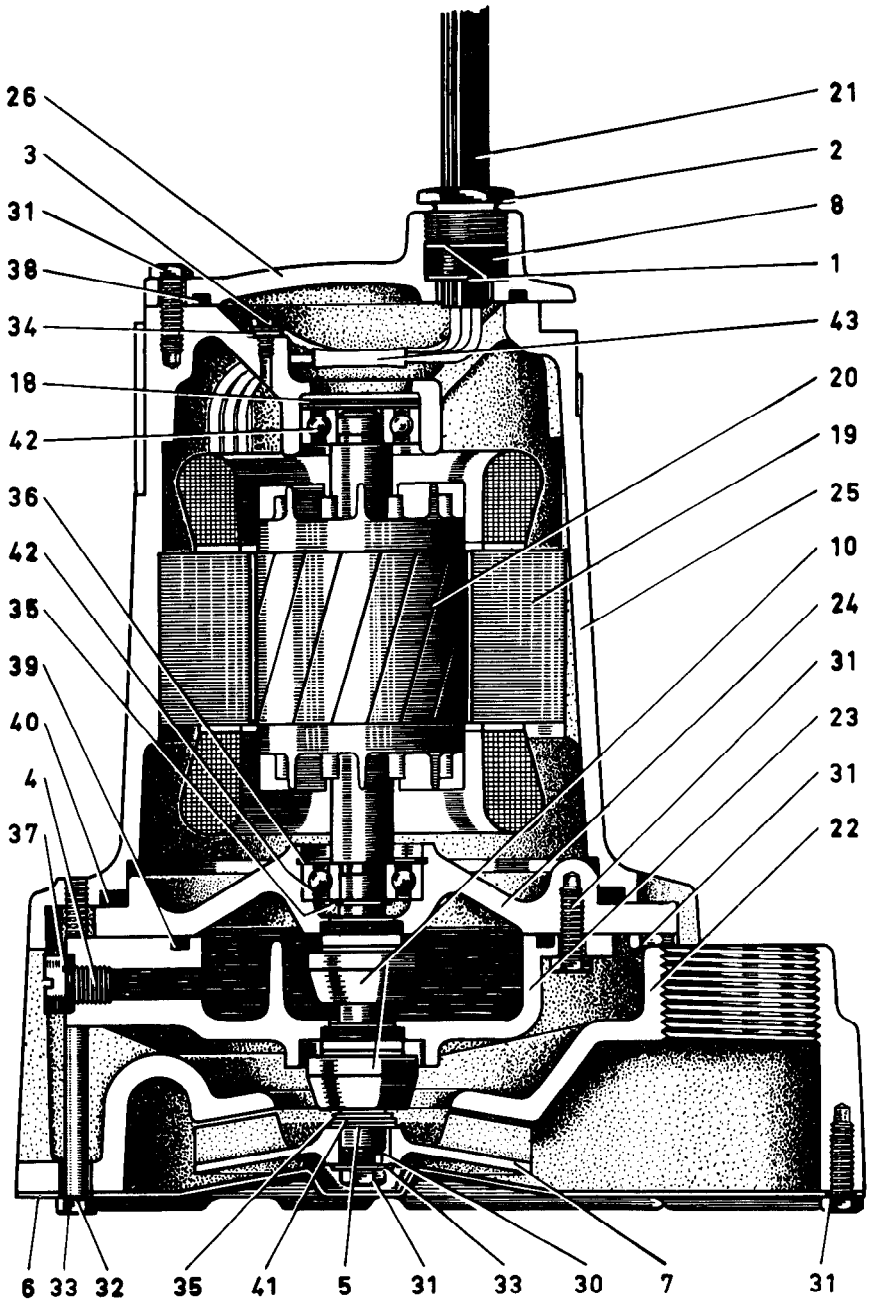

# Service log

Most recent service date	Pump No.	Hours of operation	Remarks	Sign.

# Service log

Most recent service date	Pump No.	Hours of operation	Remarks	Sign.

