



Care and maintenance



Technical particulars

The GP 3033 is an electric submersible centrifugal pump, intended for ground water pumping.

Motor: 3-phase a.c. motor for 380/220 V, 400/440 V developing 0.3 hp at 2700 rpm.

Rated current: 220 V: 1.2 A; 380 V: 0.7 A; 400/415 V: 0.65 A; 440 V: 0.6 A.

Power cable: To specification

Discharge connection: Nom.conn. no. 32 (BSP 1 1/4")

Weight, complete: 22 kg (48 lb)

1. Dimensions

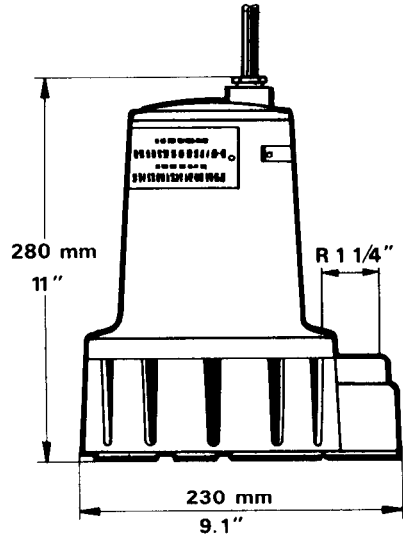

2. Capacity

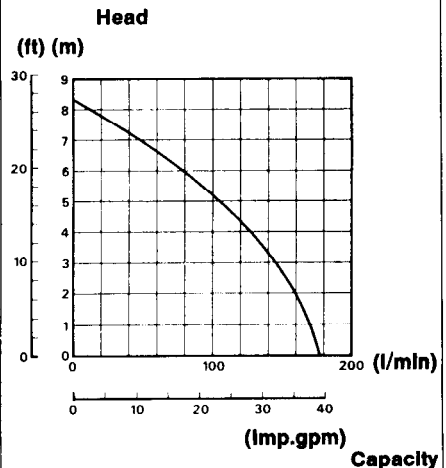

INSTALLATION

Clean the sump thoroughly before installing the pump.

The same pump can be used for varying depths of sump. Fit a cut length of galvanised steel pipe, threaded or flanged to suit sump dimensions, to the pump discharge. Lower the pump into the chamber and connect the pipe to the rising main. A sluice valve should be fitted into the pipework.

Connecting up

Isolate the power supply before working on the pump.

Electrical installations should be carried out by an authorized electrician. The motor is intended for 3-phase AC supply and can be arranged for various voltages. Always check the supply voltage and ensure that the connections are properly arranged.

S1=red, S2=brown, S3=yellow or white, S4=green, S5=blue, S6=black.

Recommended mains fuse: 6 A.

Motor protection

A motor control with overcurrent protection should always be used.

Check that overcurrent cutout is marked and set as follows:

220 V: 1.2 A; 380 V: 0.7 A; 400/415 V: 0.65 A; 440 V: 0.6 A.

If the cutout trips during normal running check the fuses before restarting. Never by-pass a tripped cutout: find out the cause of the trouble or call your Flygt service engineer.

Rotation

As a check on electrical connections, stand the pump slightly tilted (as in the figure) and switch on momentarily. The pump should jerk anticlockwise at the instant of starting. If it jerks the other way, switch two phases in the motor control. Running the pump in the wrong direction of rotation means reduced capacity and strains the motor.

Always check the rotation again after failure of a single phase or a power blackout, since phases may have become switched.

3. Connections for 220 V

from starter

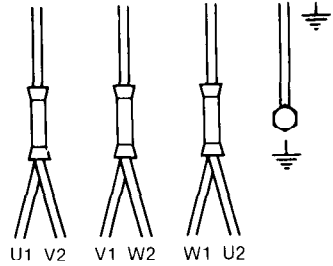

from motor

4. Connections for 380 V 400—440 VV

from starter

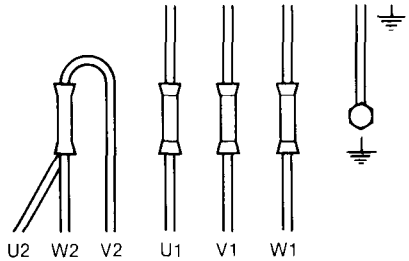

from motor

5. Starting jerk

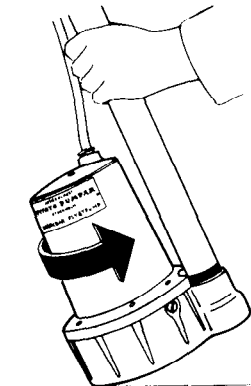

MAINTENANCE

Inspection

During inspections check that no leakage has occurred past either of the shaft seals. The procedure for this is described below, under "Oil check". If the pump is new or the seals have recently been replaced carry out a first check after one week, if possible.

Normally the pump should be inspected at least once a year.

If it works in very dirty or aggressive water, inspections should be carried out more frequently.

Oil check

Lay the pump on a workbench with the plug marked OIL uppermost. Remove this plug. Turn the pump over to allow the oil to run into a can, as shown in fig. 6.

If about 1/10 litre (1/6 pint) of oil runs out and it looks clean the seals are in good order.

If the oil is pale yellowish grey and very sluggish, or if there are distinct droplets of water in it, change the oil. Check the oil again after one week. If water is again found in the oil, the lower seal may be defective and the pump should be dismantled for overhaul, including replacement of the lower shaft seal.

Refill the oil casing with 1/10 litre (1/6 pint) of SAE 10-20 oil.

Check that the O-ring under the OIL plug is undamaged and tighten the plug securely to prevent leakage.

Major overhaul

Mainly for the sake of the ball bearings, the pump should undergo major overhaul every three years. This involves: Complete disassembly, cleaning and inspection of all sealing surfaces. Replacement of

damaged or worn parts. Cleaning and greasing of ball bearings. Replacement of lower ball bearing if water-oil mixture has penetrated the stator housing.

Checking motor insulation

During a major overhaul the motor insulation should be checked. Using a 500 V megger, an insulation resistance in excess of 1 megohm should be recorded. This applies both between phases and between any phase and the pump body.

6. Draining oil

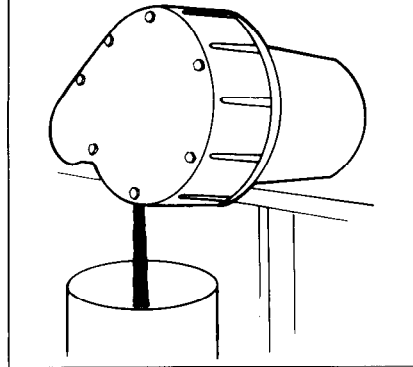

7. Shaft seal

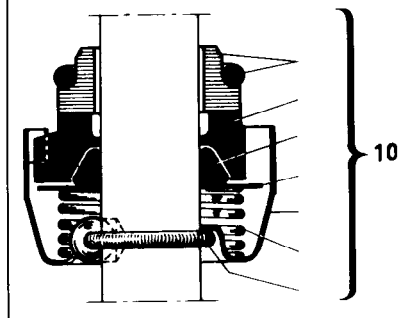

Parts list

for GP 3033.020 (3-phase)

Please state pump serial number when ordering parts. Use part numbers – not item no. – for stock records and parts ordering.

Item no.	Part no.	Denomination	Quantity
1	219 95 03	Washer	2
2	220 25 00	Gland nut	1
3	229 80 00	Earth terminal	1
4	250 84 00	Inspection screw	1
5	253 27 00	Adjusting washer	max 4
6	275 61 00	Strainer bottom	1
7	275 62 02	Impeller	1
8	275 80 01	Rubber seal	1
10	277 75 01	Shaft seal assy.	2
comprising:			
11	276 20 01	Seal ring	(1)
12	277 76 00	Washer	(1)
13	277 77 00	Spring holder	(1)
14	277 78 00	Compression spring	(1)
15	277 79 00	Tension spring with ball	(1)
16	278 98 00	Seal ring unit comprising seal ring and O-ring 17.0×3.0	(1)
17	82 76 80	O-ring 12.0×3.0	(1)
18	283 92 00	Washer	1
19		Stator	1
	285 86 34	Stator, 3-phase 380/220 V	(1)
	285 86 43	Stator, 3-phase 400–440 VY	(1)
20	285 88 00	Rotor unit	1
21	286 44 00	Motor cable	
22	286 65 00	Pump housing	1
23	286 66 00	Oil casing	1
24	286 67 00	Bearing housing	1
25	286 68 00	Stator housing	1
26	286 69 00	Junction box cover	1
	286 70 00	Carrying handle (supplied to special order)	1
30	80 74 01	Key 2×2×8	1
31	81 51 54	Screw 1/4 UNC×13	15
32	81 51 66	Screw 1/4 UNC×83	3
33	82 35 14	Washer 6.7×14	1
34	82 47 55	Spring washer 4.1	1
35	82 59 84	Circlip 12	2
36	82 61 95	Circlip 32	1
37	82 73 83	O-ring 11.3×2.4	1
38	82 78 15	O-ring 78.0×4.0	1
39	82 78 20	O-ring 90.0×4.0	1
40	82 74 17	O-ring 124.3×5.7	1
41	82 44 01	Supporting ring 12×18×1.2	1
42	83 32 41	Ball bearing SKF 6201 RS	2
43	83 44 02	Plasti-Grip	3–4
	90 17 51	Oil SAE 10–20	0.1 litre 1/4 pint
	90 20 50	Bearing grease, BP Energrease LS3 or Shell Alvania Grease 3	as reqd.

8. Section of pump

