

WORKSHOP MANUAL

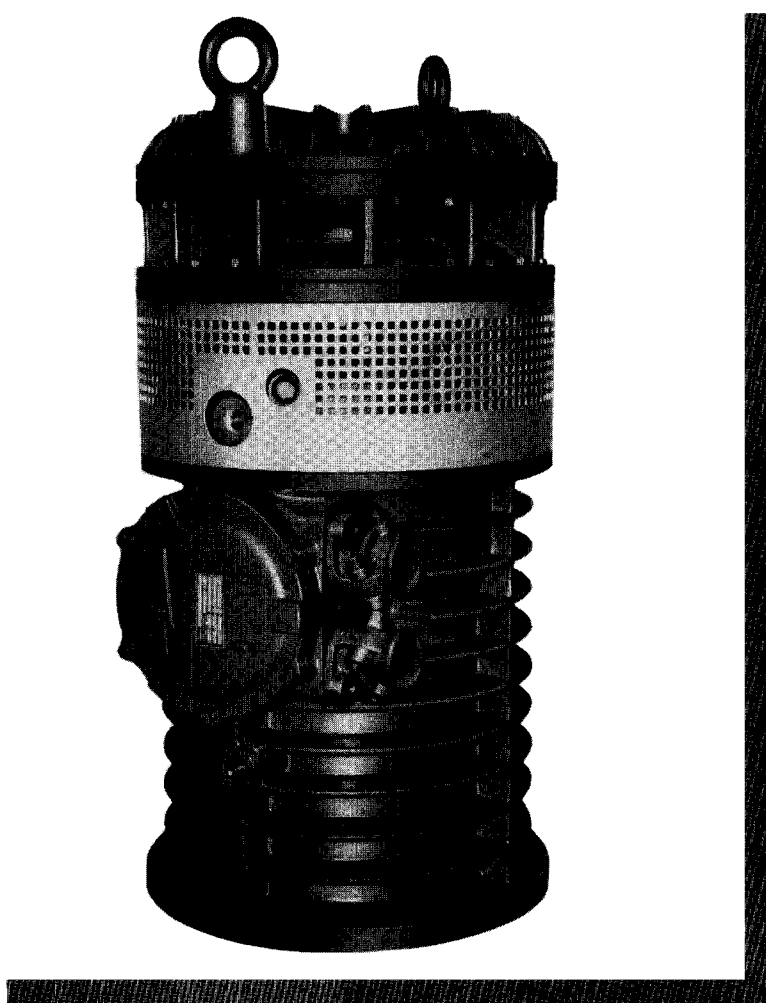

DATA PLATE INTERPRETATION

General data plate

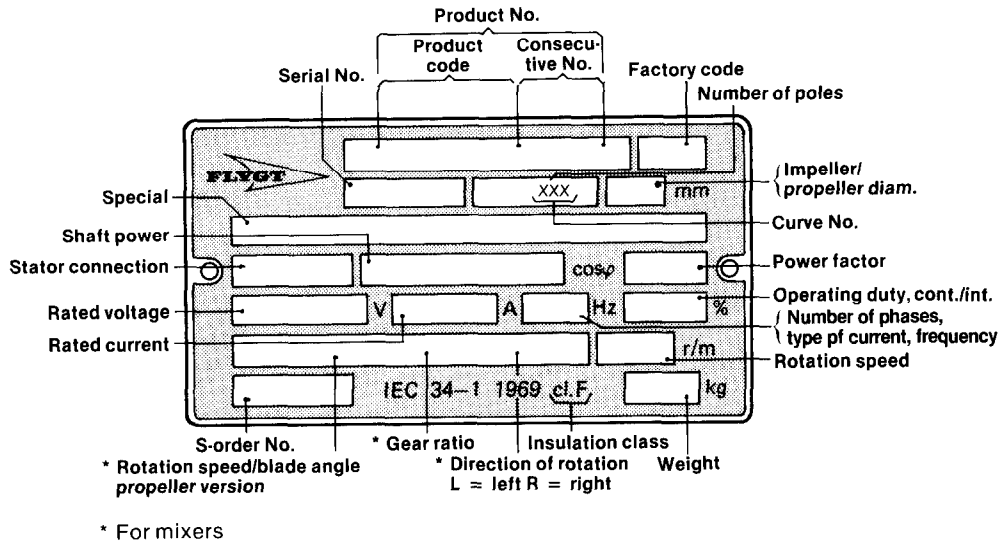

Approval plates see "Care and maintenance"

How to use the workshop manual

This workshop manual describes how pump 2400 is taken apart and put together in connection with service and reconditioning work.

The manual contains numbered pictures — and sometimes drawings — showing different steps in the work. These steps are described on the fold-out pages at the back of the manual.

Information is also provided on special tools that not only facilitate the work but are sometimes necessary for a successful result.

We would also like to point out that the practical work on this pump has been done under very favourable working conditions. We have disassembled and assembled a factory-new pump and worked in a modern, well-equipped workshop.

Pumps that have been in service for some time acquire a "patina" that may necessitate the use of other work methods than those recommended here.

General rules

Wash the outside of the pump thoroughly and blow it dry.

Clean all parts thoroughly — especially O-rings seats — prior to assembly.

Always replace all O-rings, other seals and — in connection with bearing replacement — any lock washers and ring nuts.

Oil moving parts, O-rings and threads — do not touch sealing surfaces of the mechanical shaft seals.

Touch up the anticorrosion coating during service.

Safety precautions

Make sure that the lifting equipment is rated for the load you are going to lift and that it is in good condition.

Do the work on a stable work bench.

Beware of the risk of electrical shock.

Check that the tools are in good condition.

Keep a first-aid kit handy.

Wear safety goggles at hydraulic removing of bearings.

Contents

Technical data	4
Winding resistances	4
Lubricants	5
Tools	5
Impellers	5
Electrical connections	6
Specially approved pump	8
Notes	10
Hydraulic section	
Disassembly	28
Assembly	40
Drive section	
Disassembly	32
Assembly	36
Exploded views	29, 33, 37, 41
Cutted view, seals	45

Technical data

For weights, amperages, voltages, power ratings, rpm, see the pump's data plate.

Tightening torques

Impeller screw	200 Nm (148 ft lb)
Inspection screw	10—20 Nm (7.5—15 ft lb)
Oil screw	20 Nm (15 ft lb)

Oil volume 11.5 l (12 US quarts)

Winding resistances at 20°C (68°F)

Stator No	Resistance Ohm/phase
382 53 38	0.0533
44	0.0620
52	0.0943
59	0.0601
497 39 38	0.0533
48	0.0833
52	0.0943
59	0.0601
560 86 30	0.0386
38	0.0467
40	0.0385
44	0.0556
48	0.0757
52	0.0871
55	0.0989
59	0.0493

Lubricants

Order No	Description
90 20 58	Bearing grease 1 kg (2.2 lb). Mobilith SHC 460
90 17 53	Shell Tellus Oil 32

Tools

Order No.	Description	Remarks
82 30 92	Lifting eye	
83 96 69	Temperature indicator sticks	
83 95 42	Oil drainage pump	
84 13 62	Ball bearing extractor, three-shanked	
84 13 68	Hydraulic jack	
84 20 50	Internal extractor	
84 20 51	Counter stays	
84 13 63	Yoke	
84 15 08	"C" spanner	
332 91 00	Stop spring remover	
432 44 00	Bearing puller set	
453 32 00	Ball bearing puller set	
394 70 00	Stator lifting tool	
398 16 00	Ball bearing extractor	Outer ball bearings
398 53 00	Assembly sleeve	For fitting seal
398 54 00	Assembly sleeve	For fitting seal
398 55 00	Assembly sleeve	For fitting seal
398 56 00	Sleeve	For fitting seal
398 60 00	Assembly sleeve	For adjustment of HT impeller
400 21 00	Adjustment tool	For HT impeller
453 30 00	Adjustment tool	For HT impeller
400 23 00	Sleeve	For fitting seal
400 24 00	Assembly tool	For fitting seal
400 29 02	Heating iron	For ball bearing
462 30 00	Burner set	

Impellers

Impeller Order No	Impeller Code No
MT 385 62 00	231
MT 385 63 00	232
HT 382 86 00	233
HT 382 86 02	243
HT 382 82 00	234
HT 382 82 02	244

Electrical connection

See also "Care and maintenance".

Stator connection

The main stator leads are colour-marked as follows:

- U1 = Red
- V1 = Brown
- W1 = Yellow
- U2 = Green
- V2 = Blue
- W2 = Black

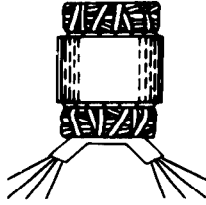

The main stator leads are connected as illustrated in the figures.

Connect the thermal protector leads (white) to the small separate terminal board (T1, T2).

Connection of the motor cable

Connect the motor cable as illustrated in the figures.

NOTE! For safety reasons, the earth lead should be approx 100 mm (4") longer than the phase leads. If the motor cable is jerked loose by mistake, the earth lead should be the last lead to come loose from its terminal. This applies to both ends of the cable.

Connect the control leads from the motor control circuit to the separate small terminal board (T1, T2).

Check on the data plate which connection Y or Δ is valid for the voltage supply. Then, depending upon the mains voltage, fit the closing links between the terminal screws for Y or Δ connection, se figures.

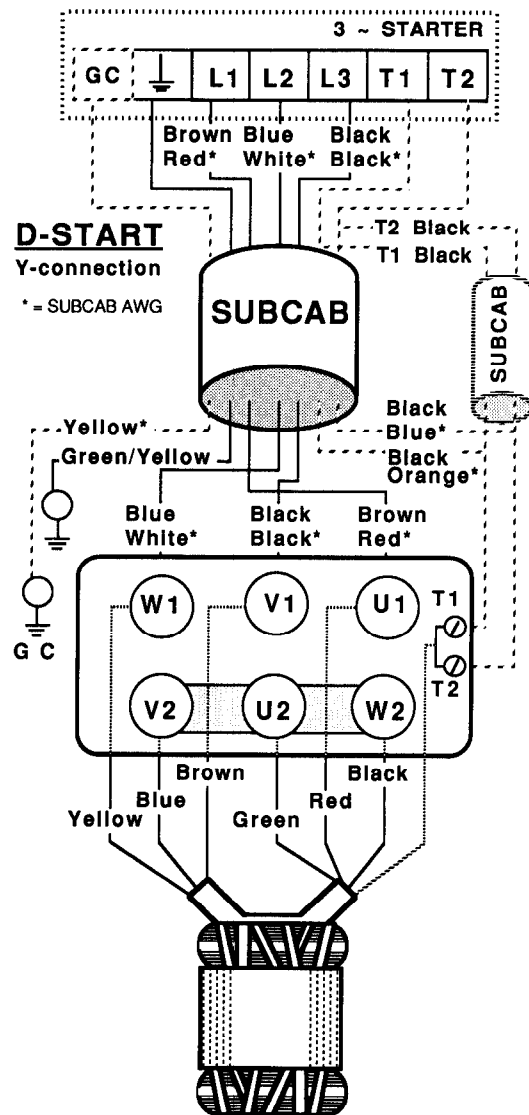
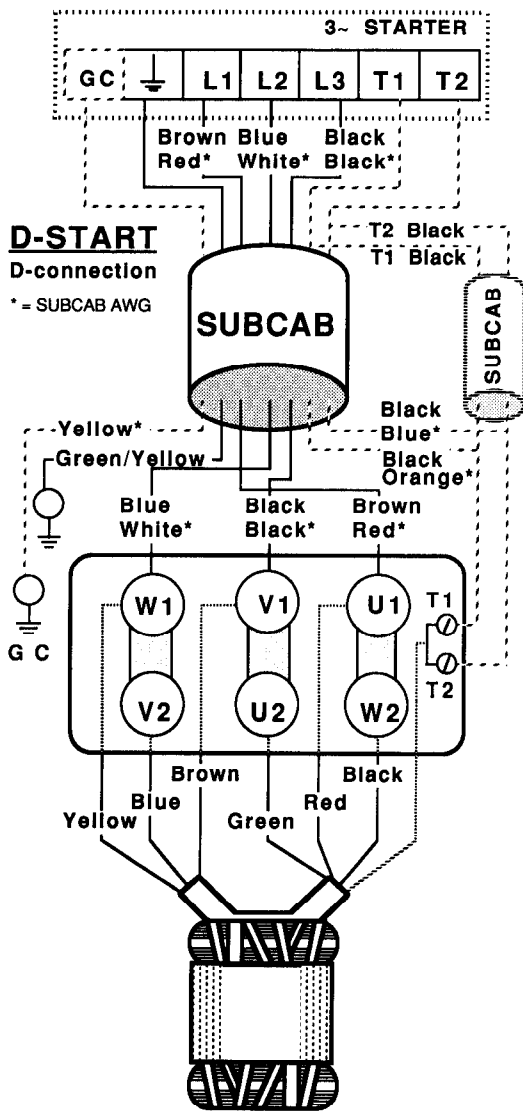

If star-delta start is used, both motor cables are connected as shown below. Closing links are not used with star-delta start.

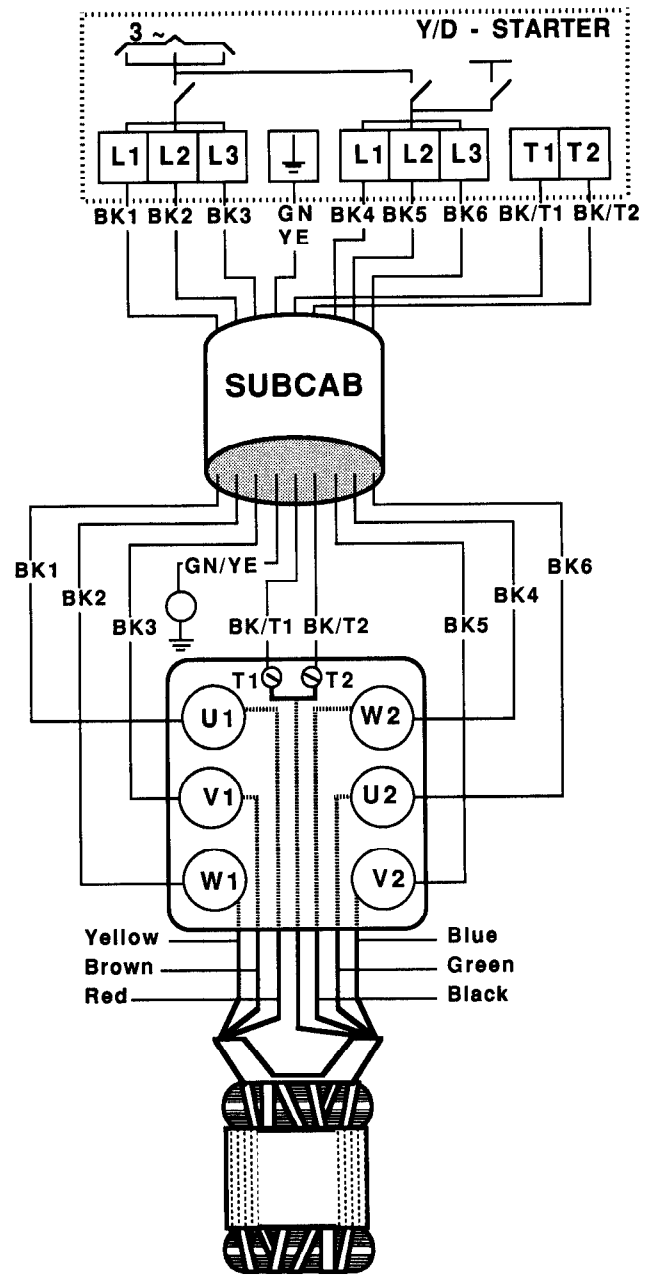
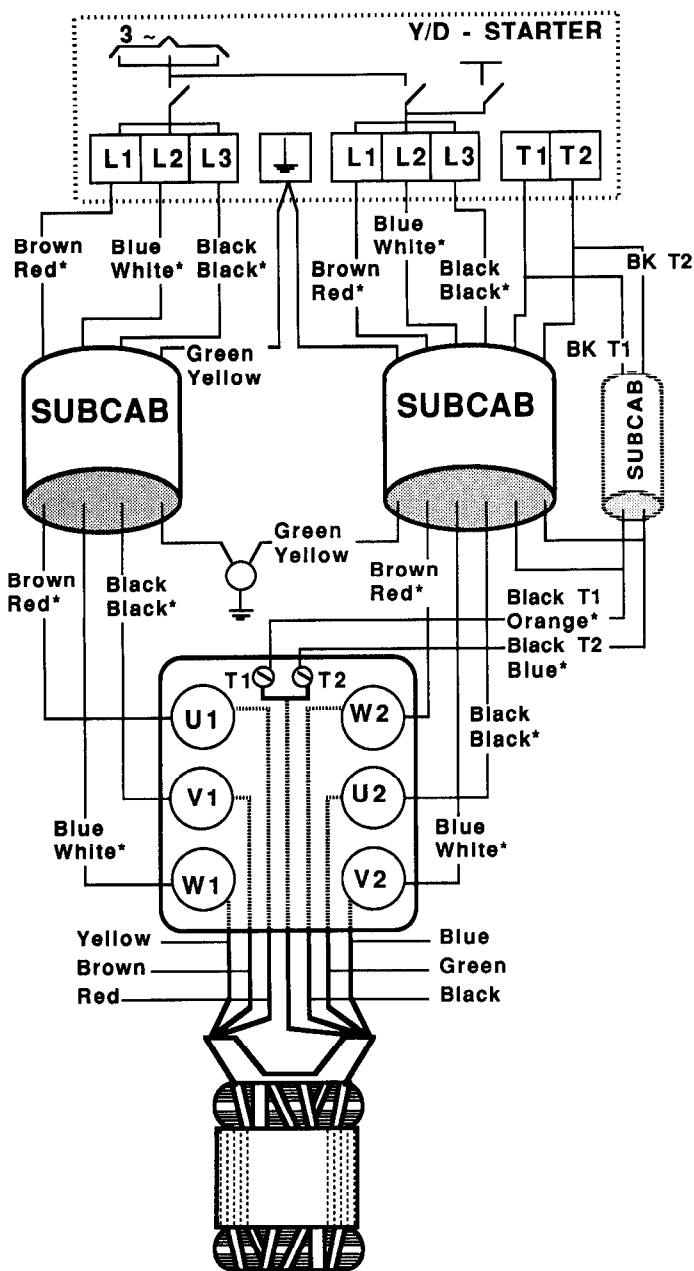

Specially approved pump

NOTE: This workshop manual also describes the specially approved pump versions. For identification, see the pump data plate and approval plate.

To ensure that the pump complies with the regulations and approval of the authorities, use only genuine Flygt spare parts when carrying out repairs.

Specially approved pump may only be repaired and adjusted by Flygt or workshops and/or workshop personnel authorized by Flygt.

Always check the dimensions of vital parts before assembly, see Fig.

Always carry out insulation tests on assembled pumps and run them on test before delivery.

Flame Path	Min Flame Path Width F mm X	Diameter ISO Symbols for tolerances		Flame Path Gap G	
		mm	Deviation mm	max mm	min mm
I	26.5	∅135 H8	+0.063 0	0.169	0.043
		∅135 f8	-0.043 -0.106		
II	—	420 h8 R7		Shrink fit	
III	—	245 ± 0.06 248 ± 0.05			
IV	26	∅430 H8	+0.097 0	0.180	0.020
		∅430 g7	-0.020 -0.083		
V	26.2	∅170 f8	+0.043 -0.106	0.169	0.043
		∅170 H8	-0.063 0		
VI ¹⁾	—	80 h8 81.5		1.546	1.0
VII ¹⁾	33.5	80 h8 B8		0.292	0.200
VII ²⁾	26	∅80.35 M7	0 -0.035	0.363	0.315
		∅80 h5	0 -0.013		
VIII	26	∅275 g8	-0.017 -0.098	0.179	0.017
		∅275 H8	-0.081 0		

¹⁾ 2400.421

²⁾ 2400.590/690

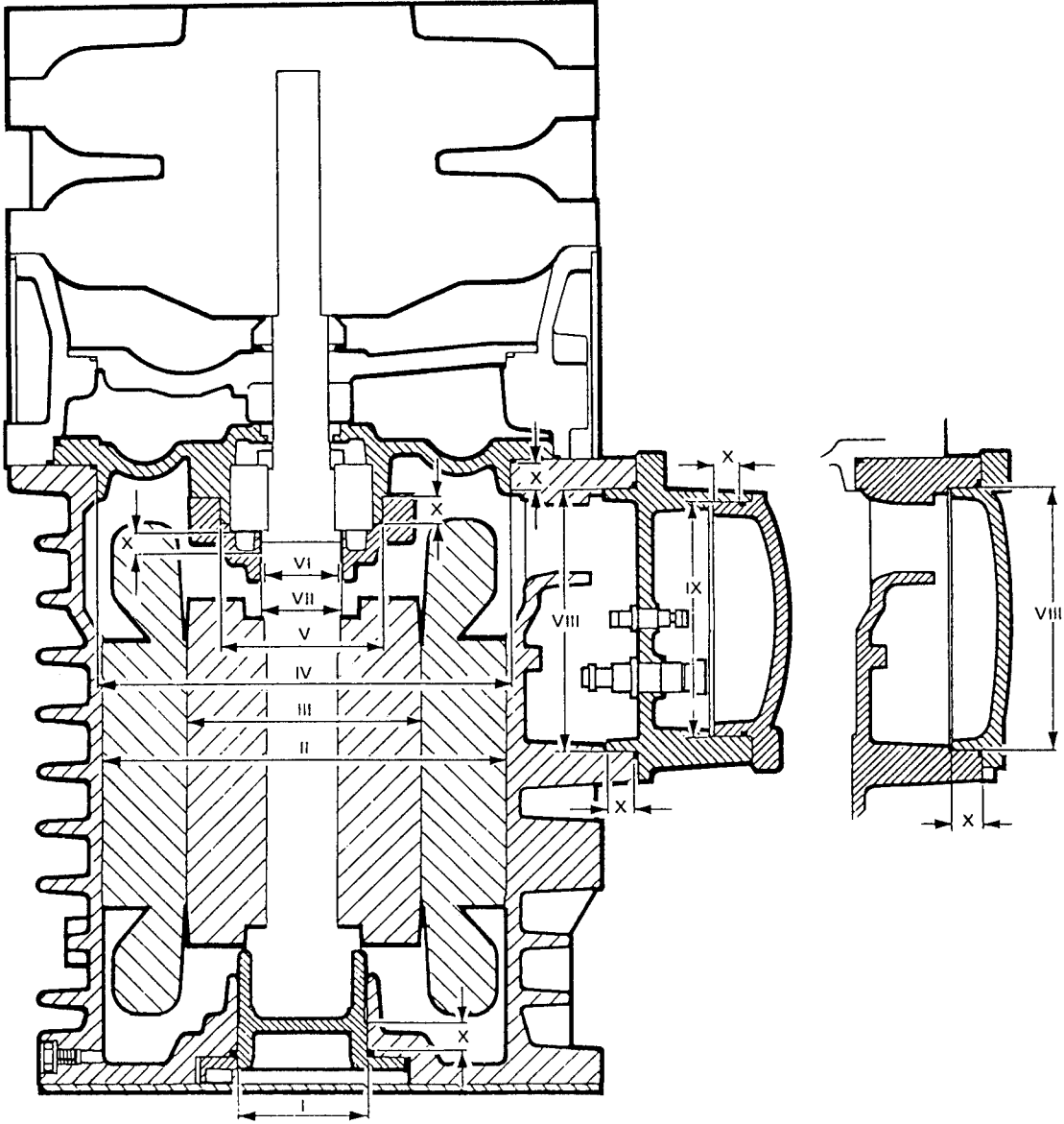

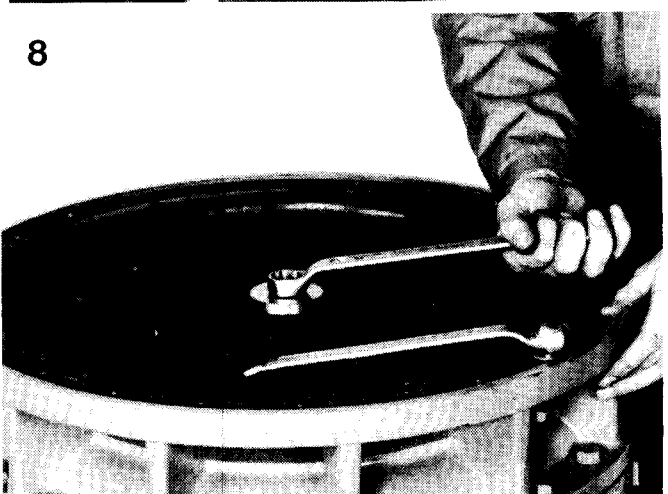
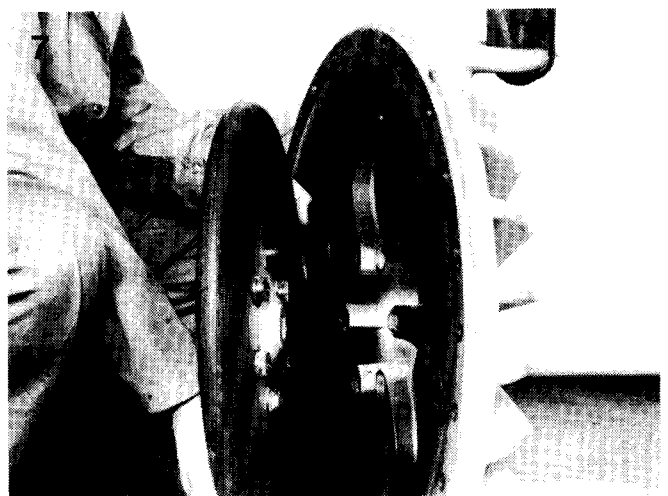
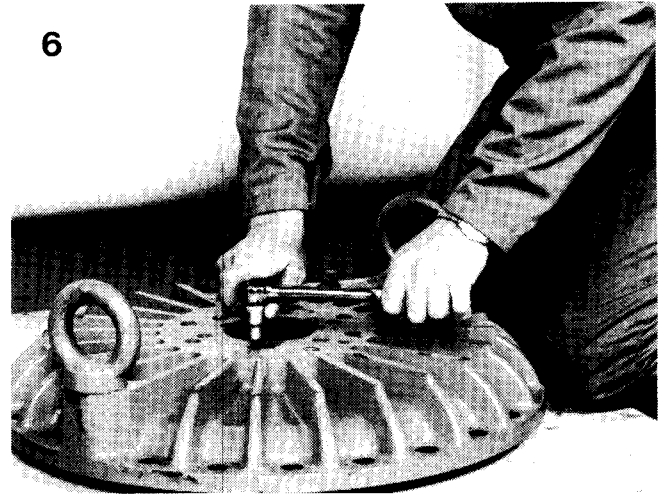
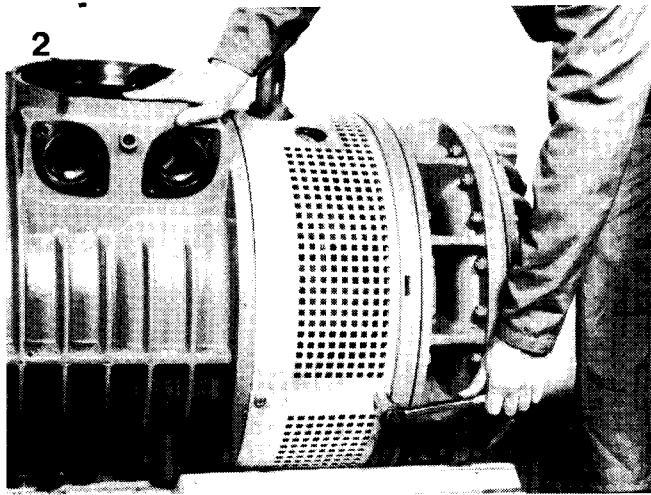
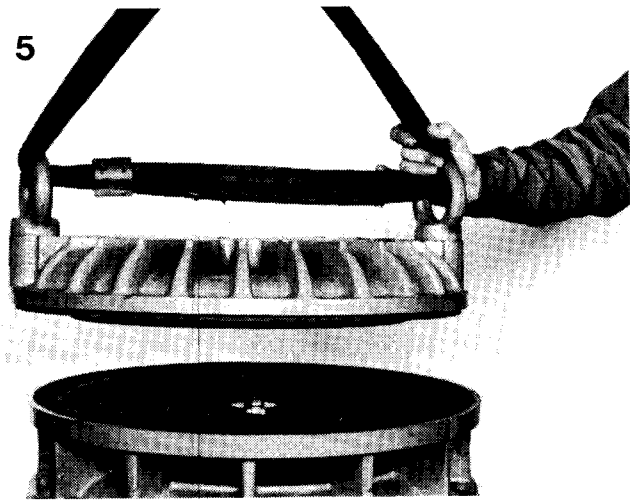
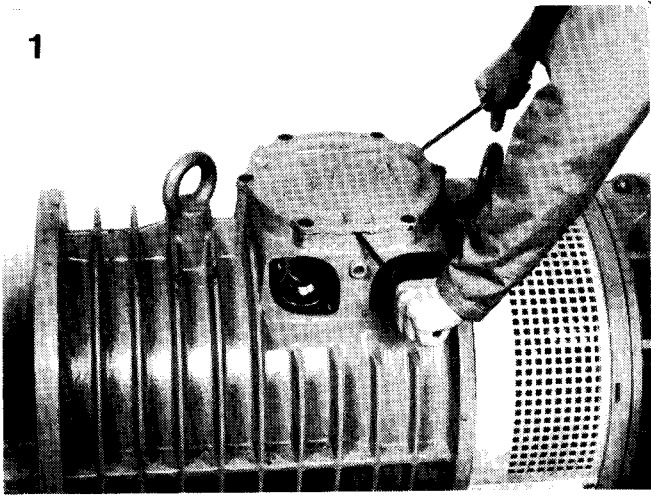

9

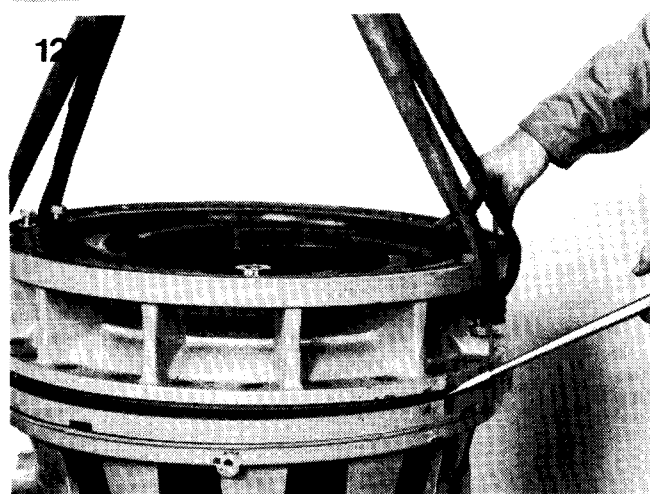
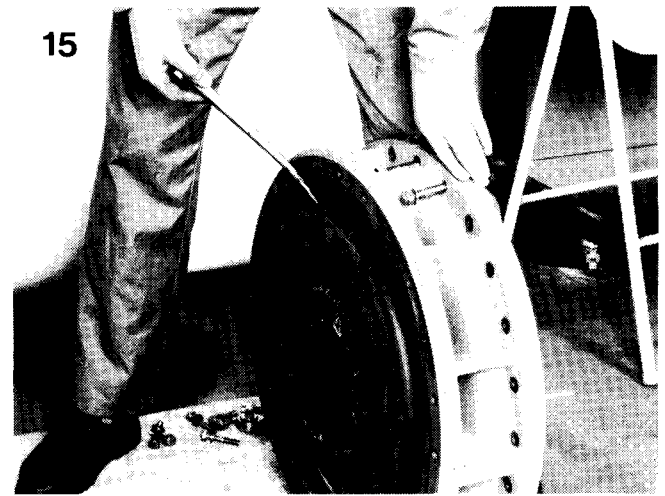
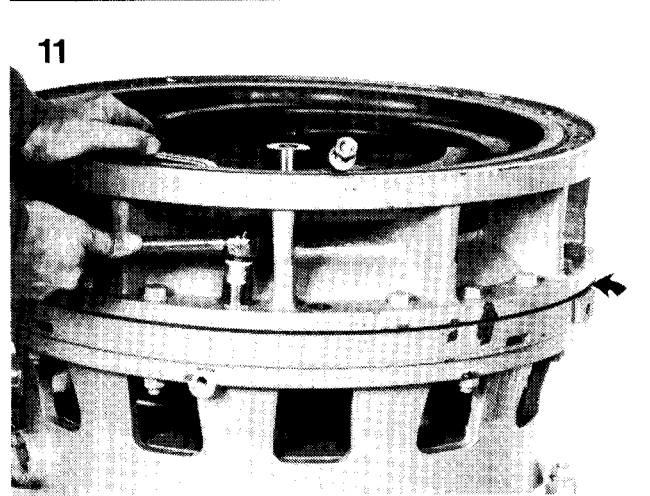
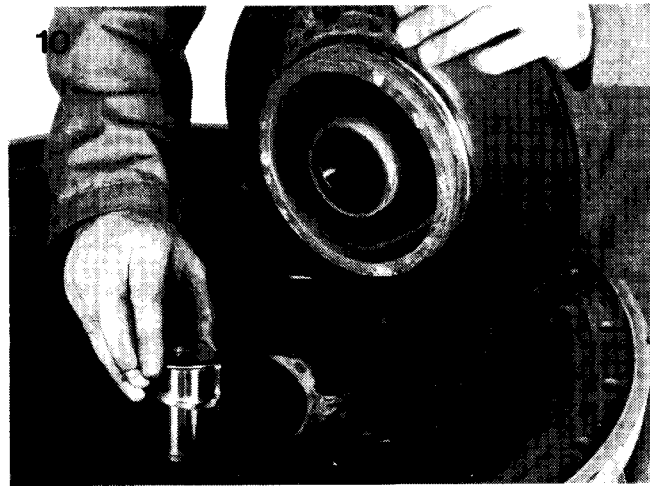
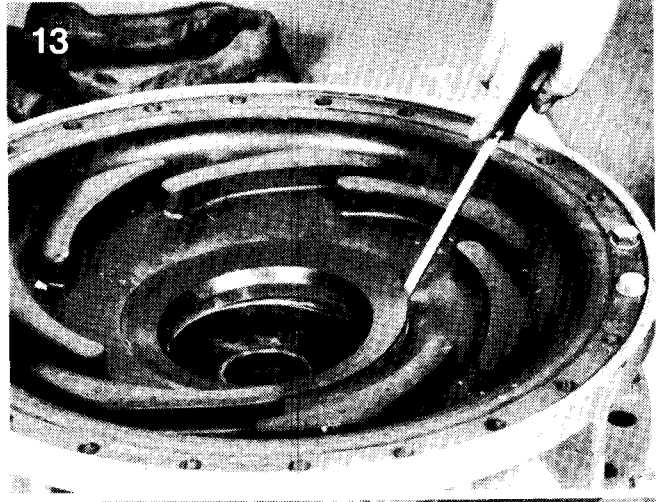
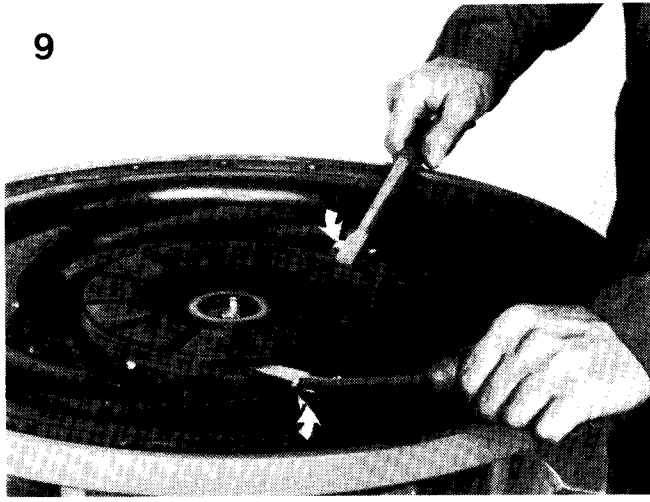

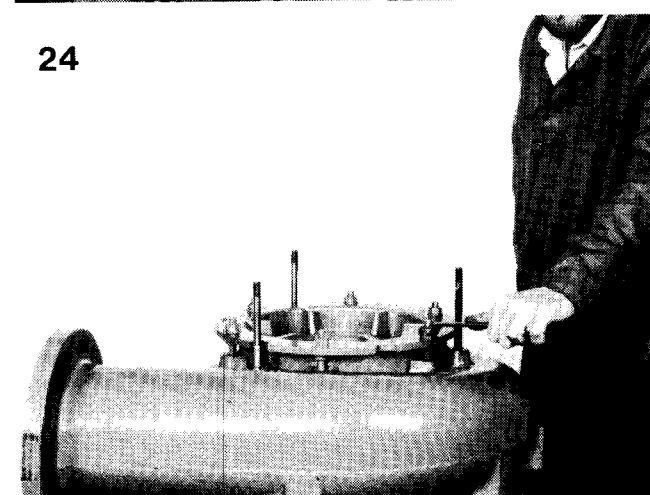
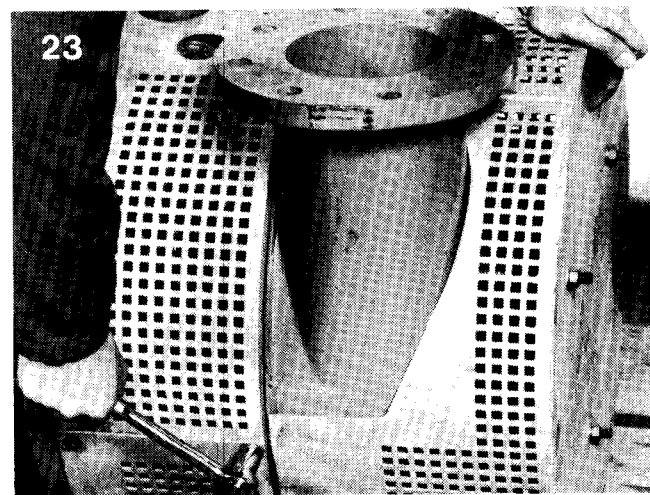
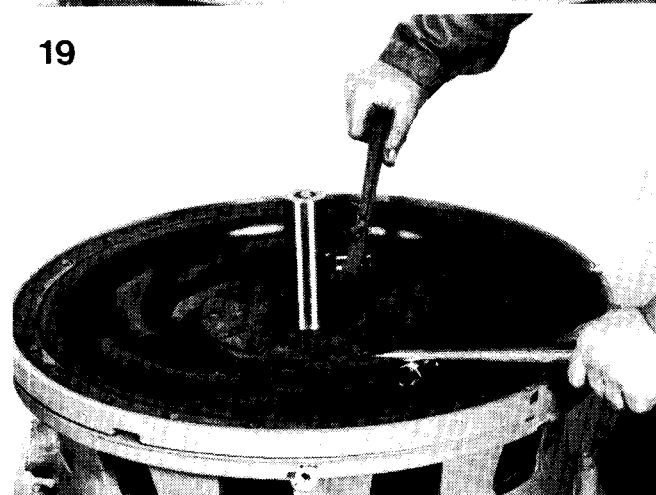
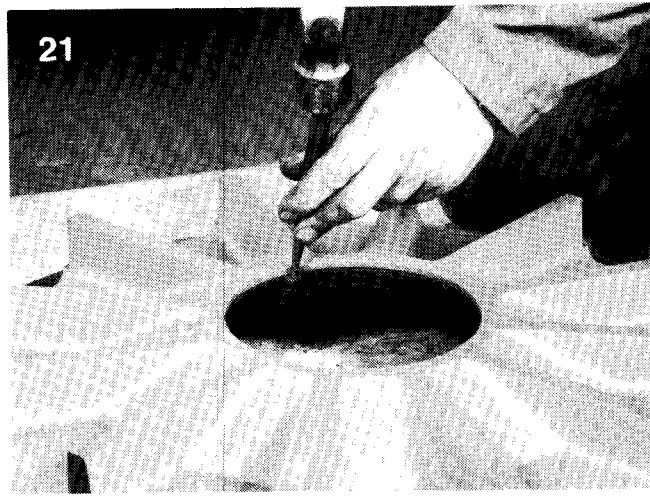

25

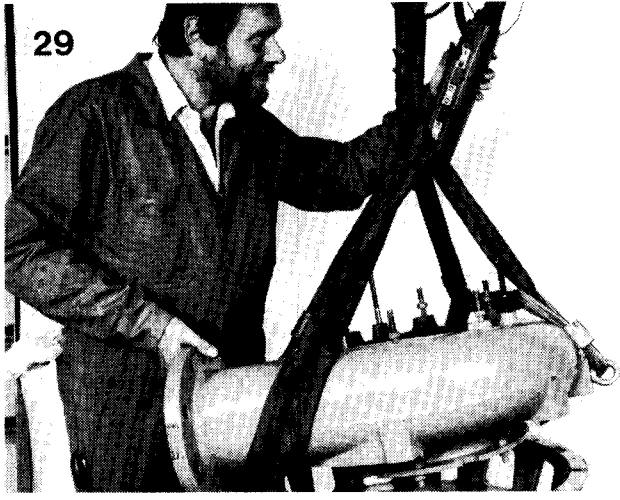

26

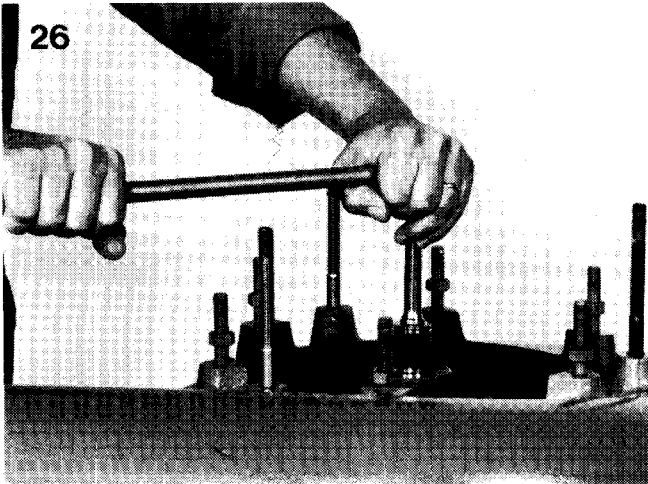

30

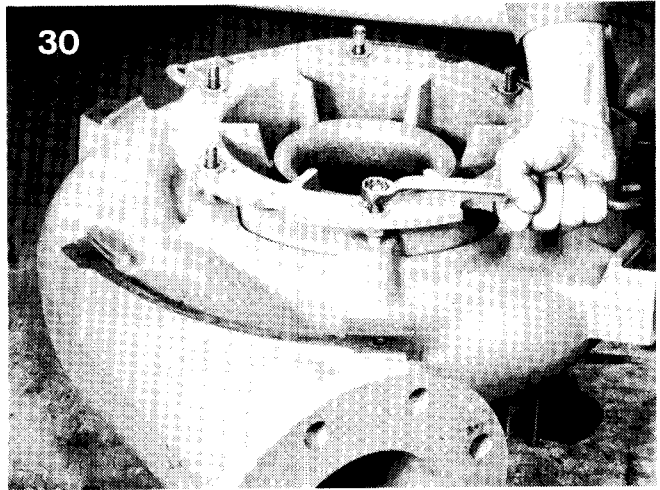

27



31

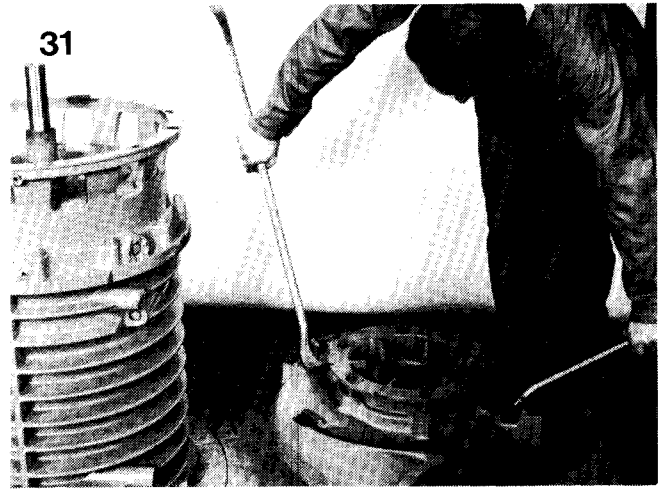

28

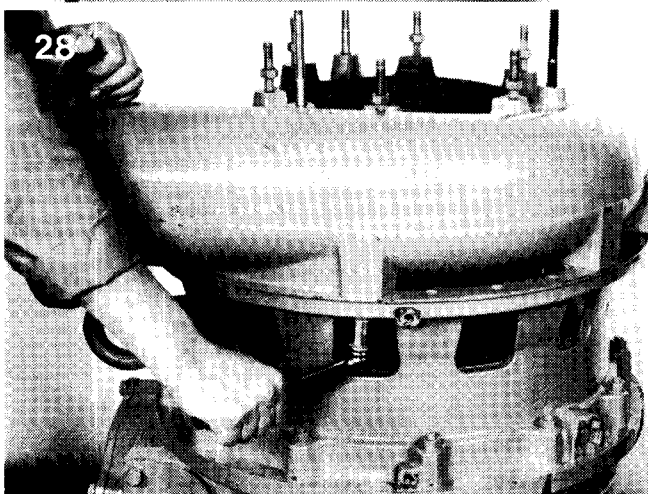

32

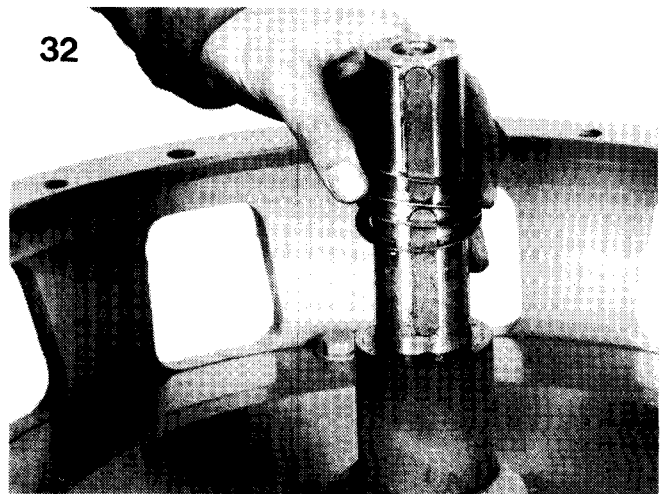

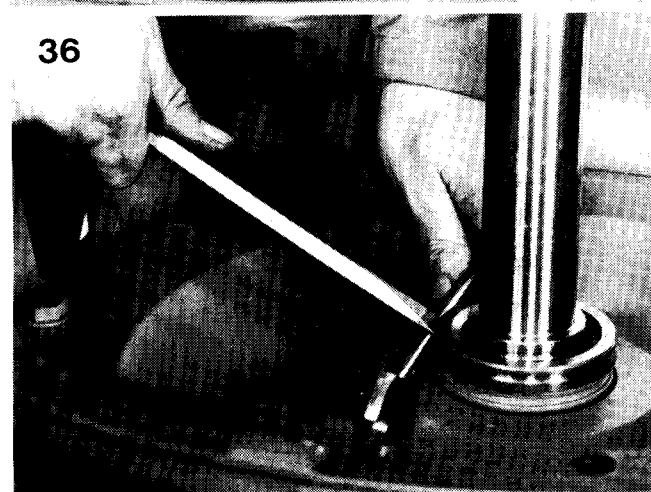
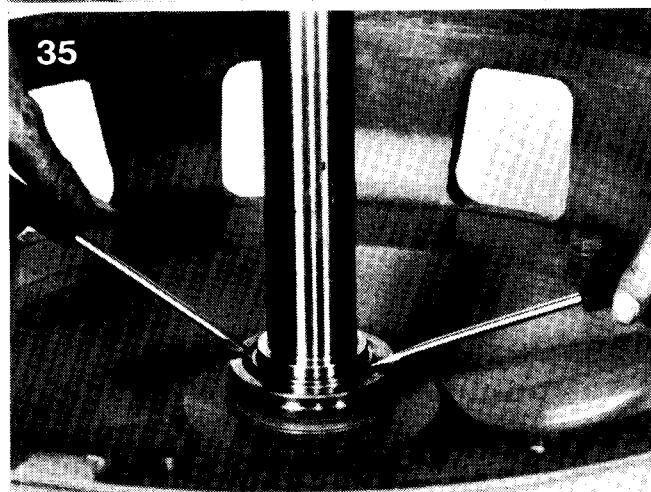
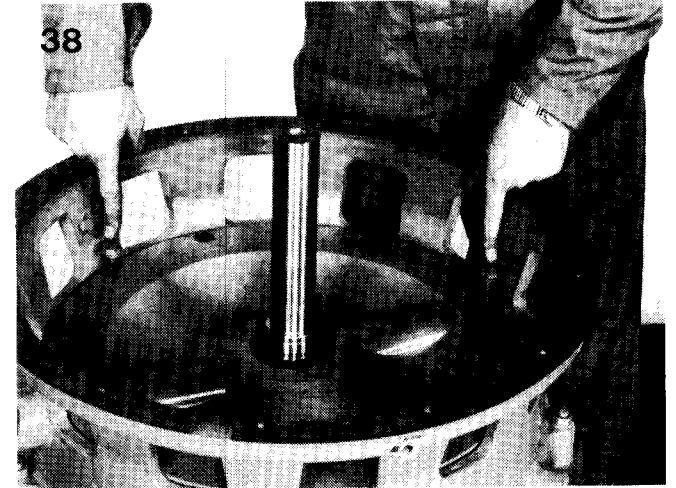
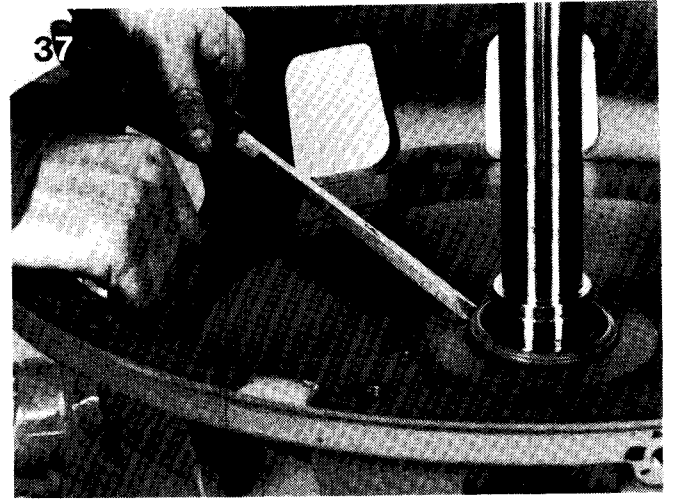
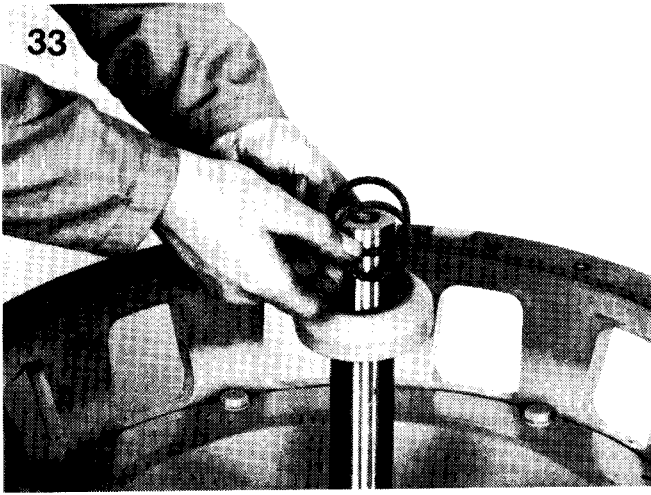

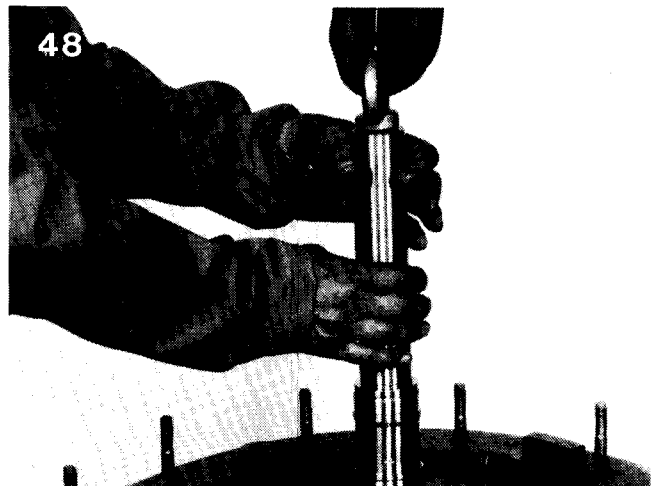
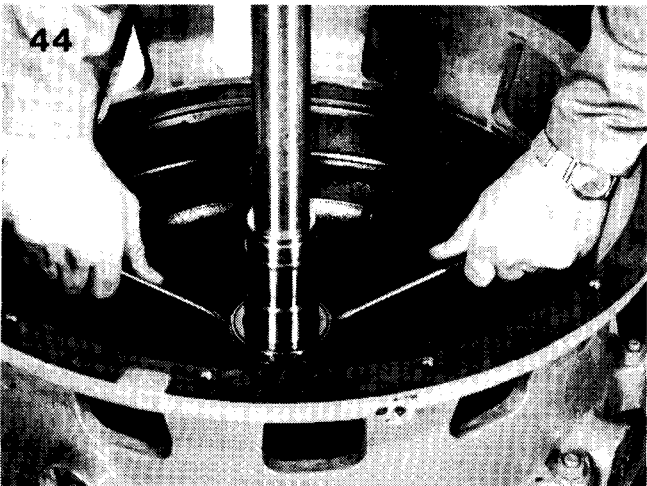
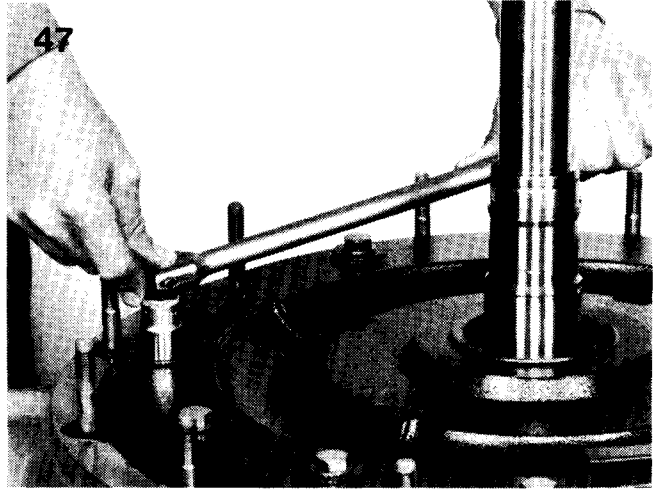
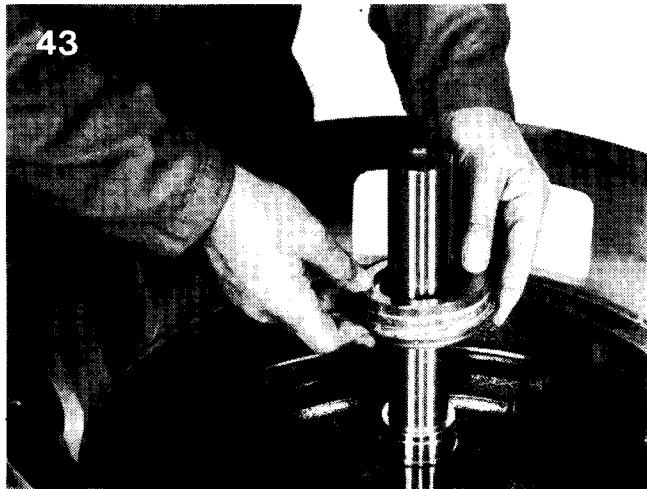
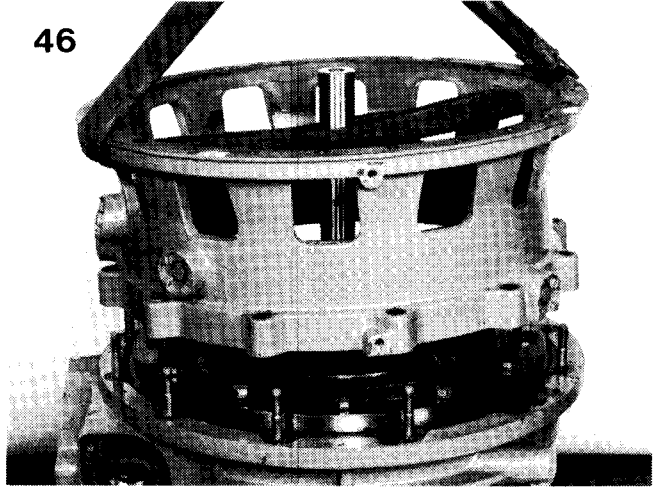
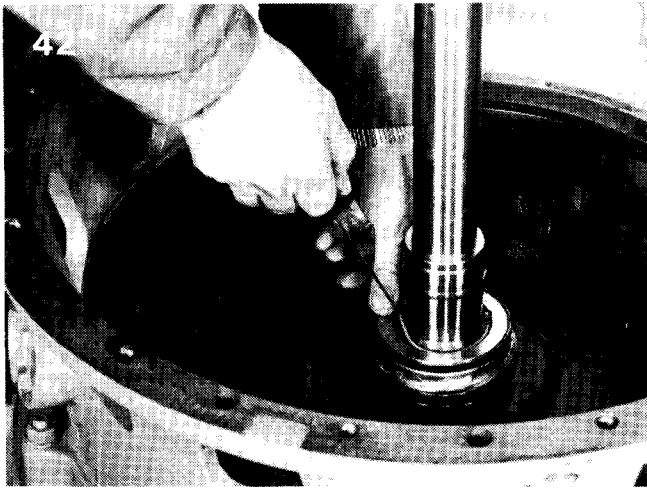
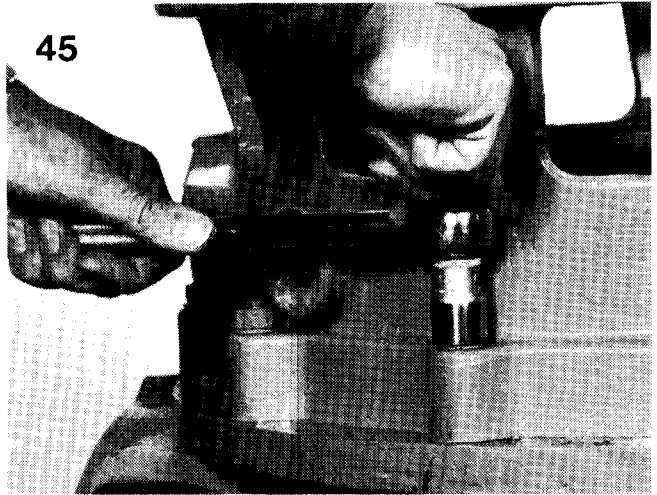
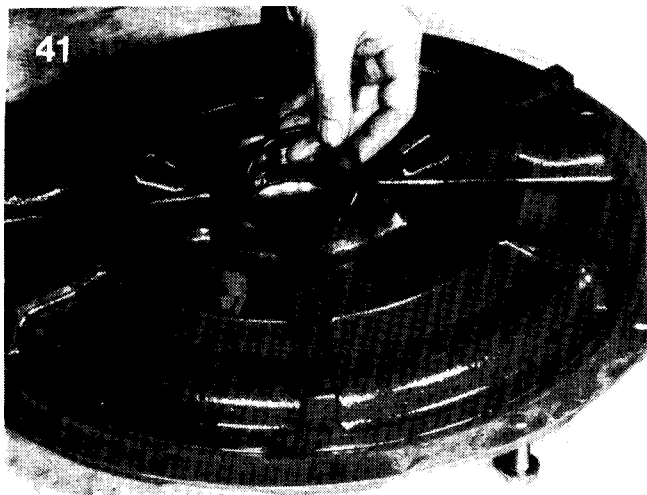

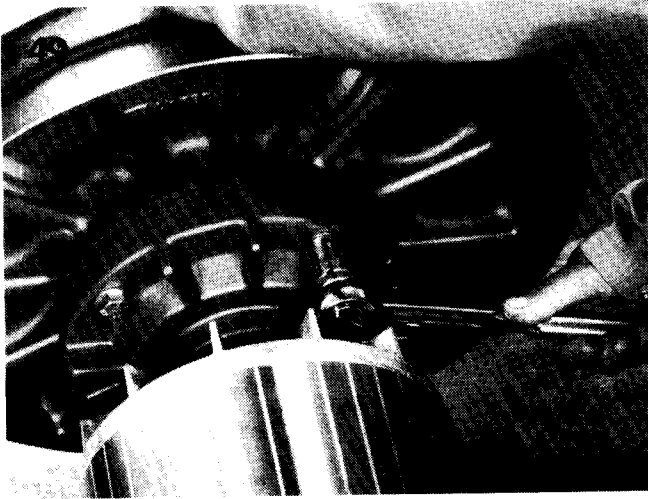

50

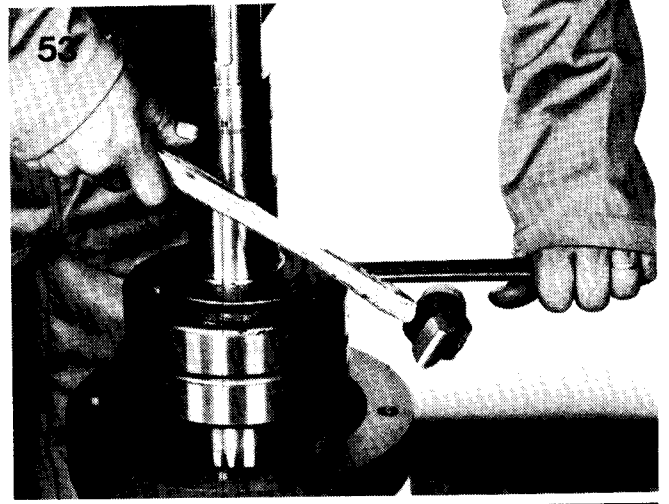

53

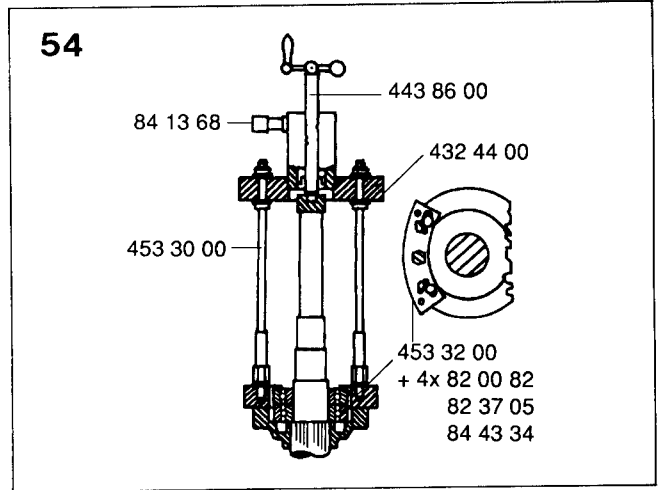
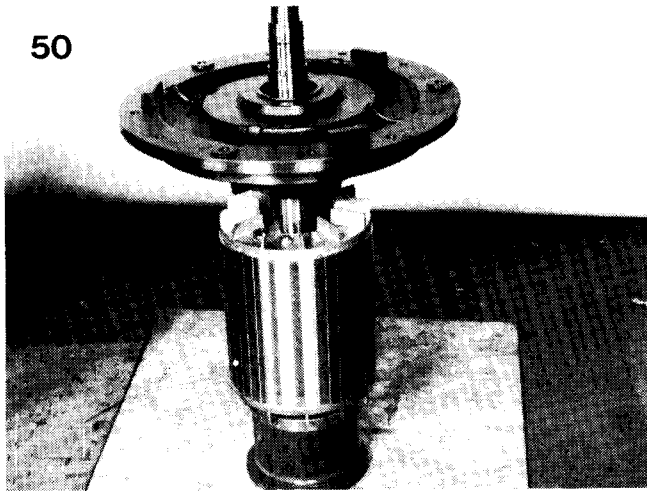

54

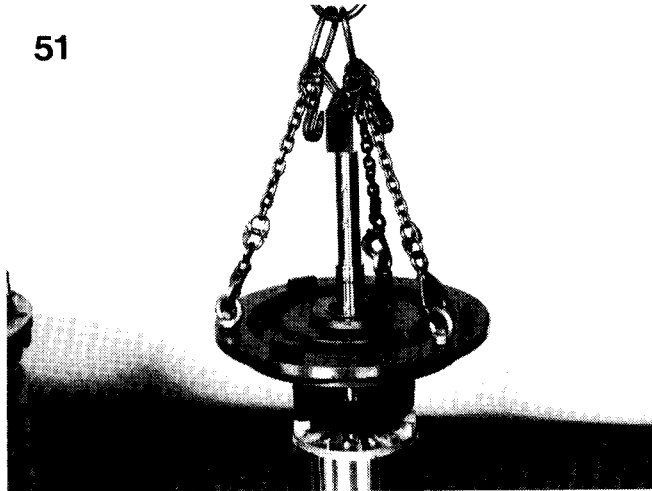

51

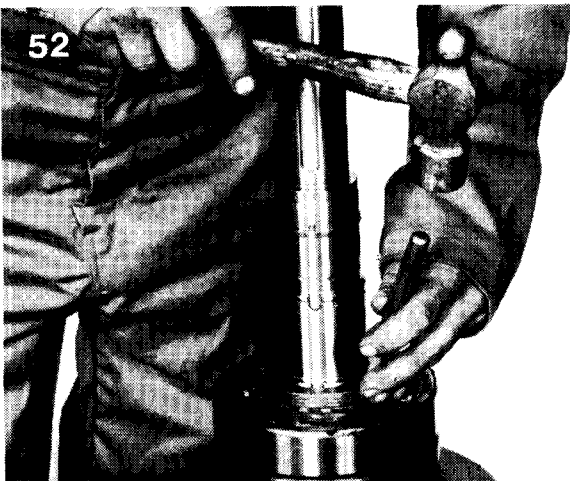
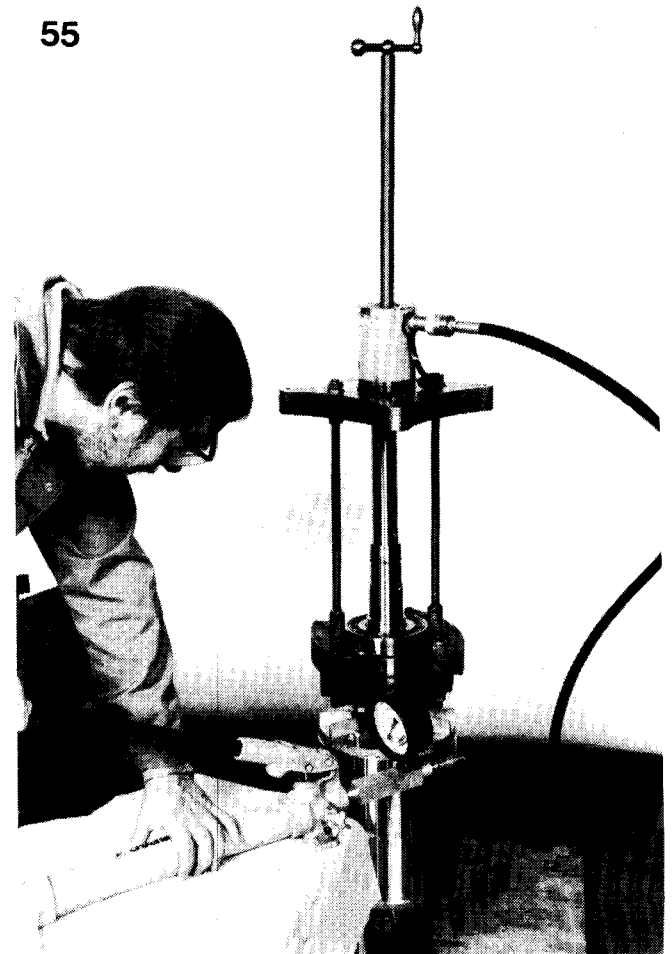

52

55

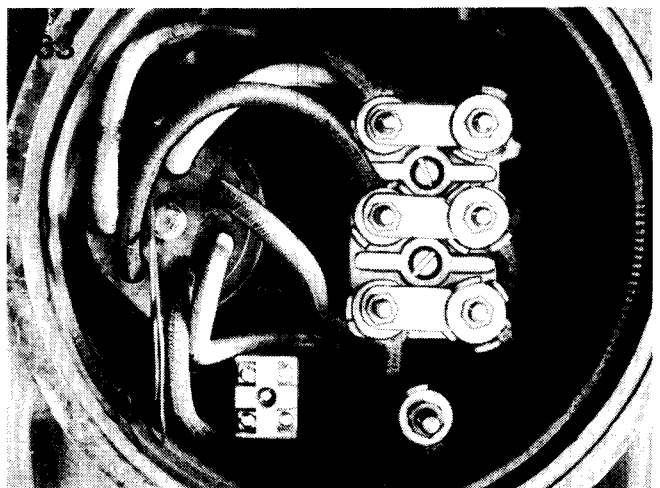
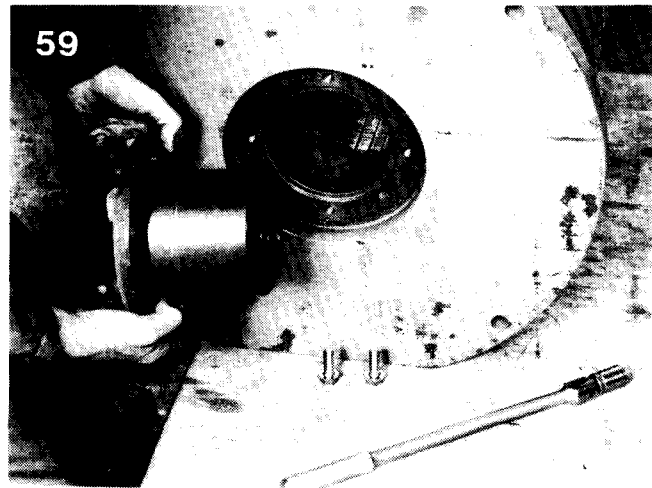
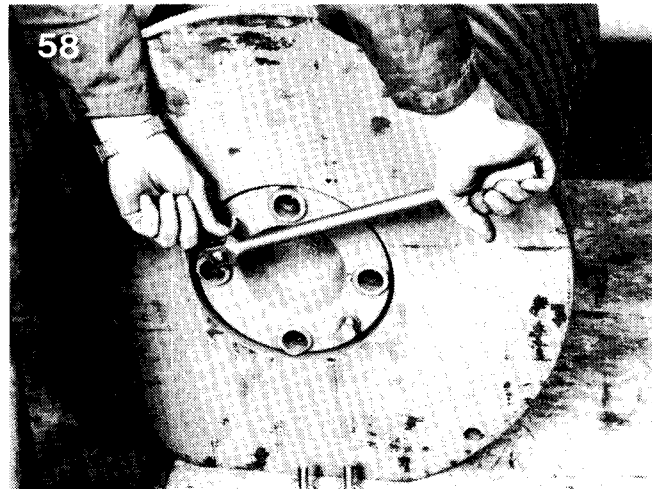
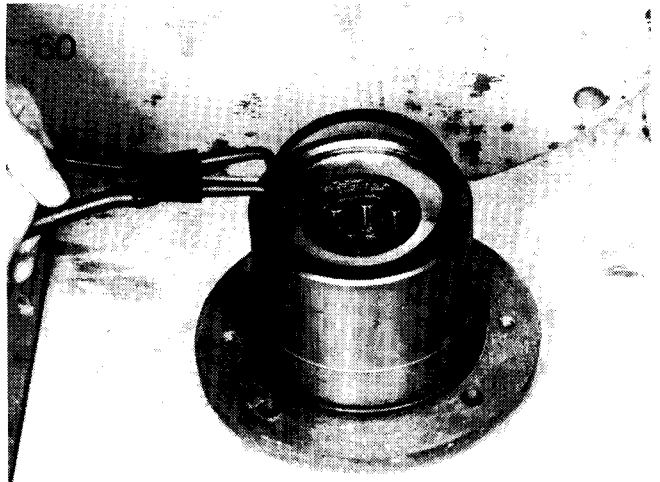
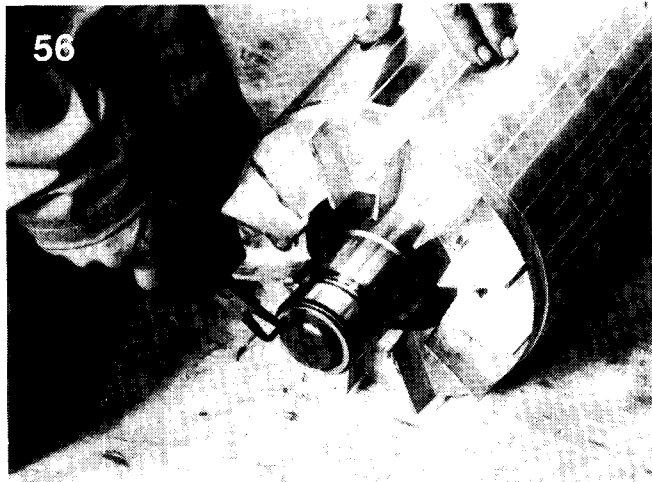

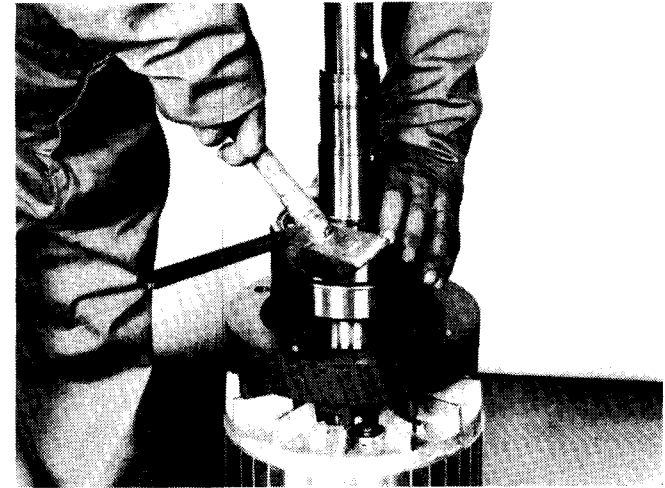
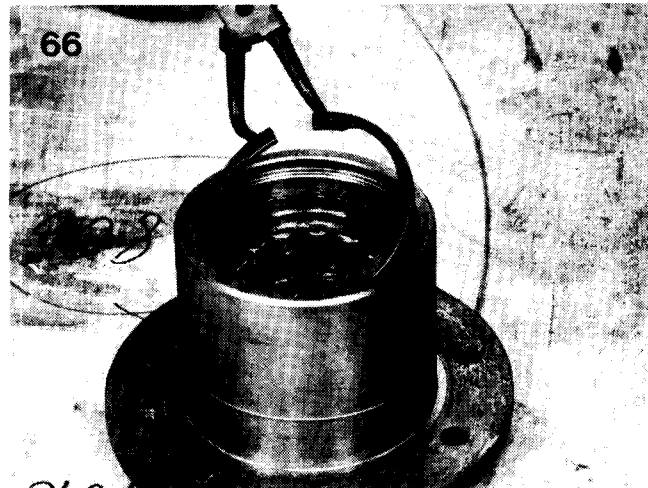
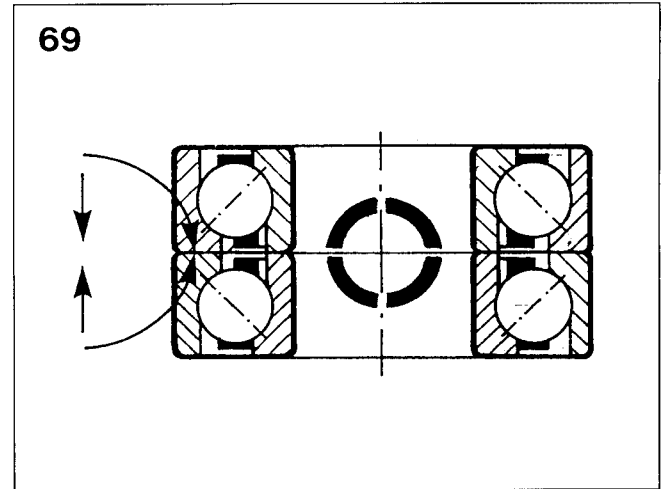
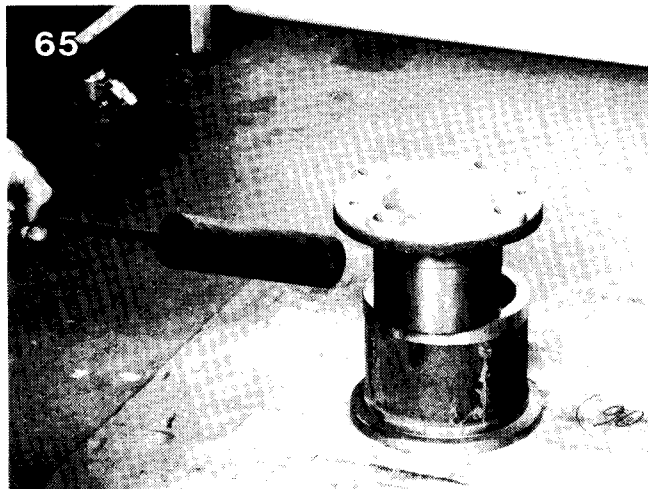
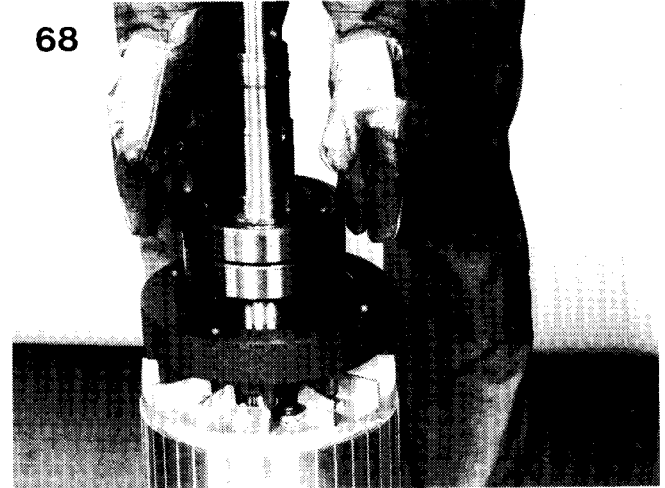
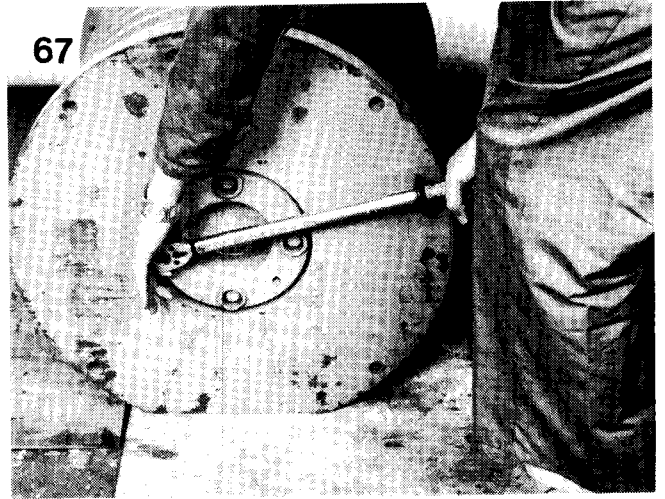
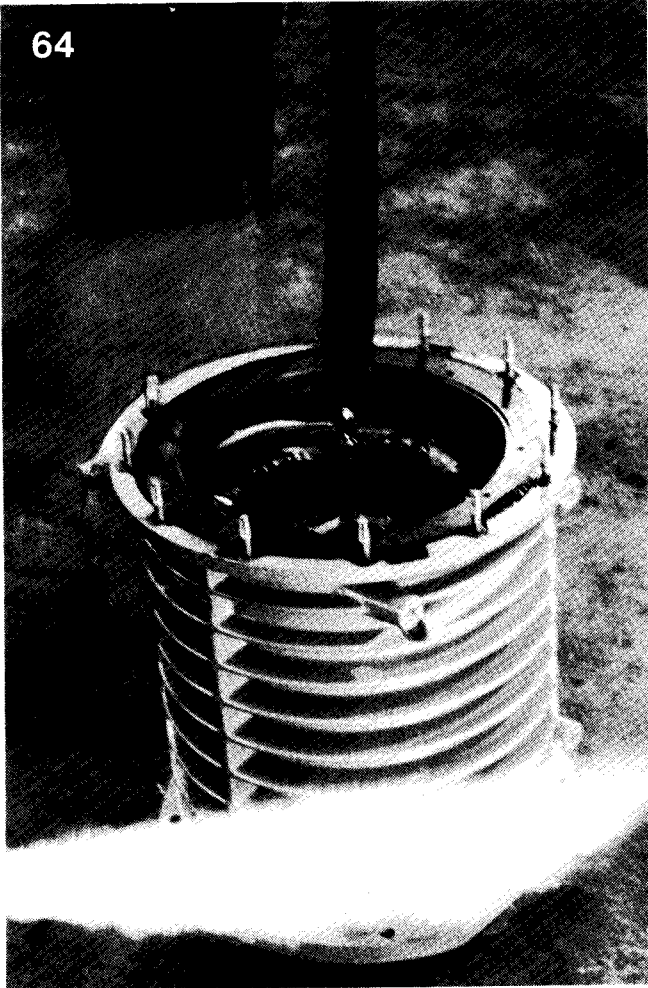

71



75

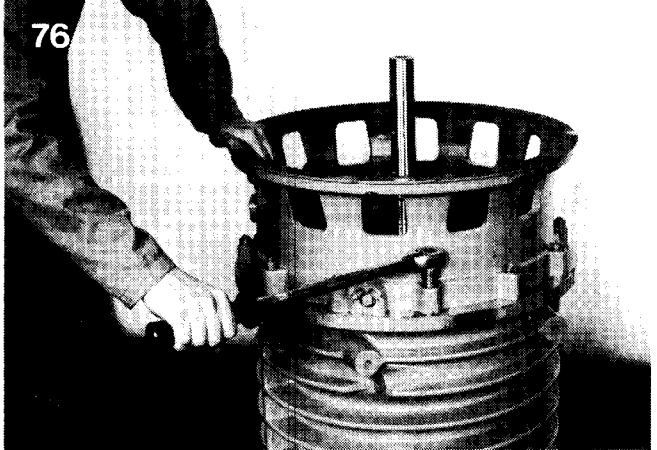
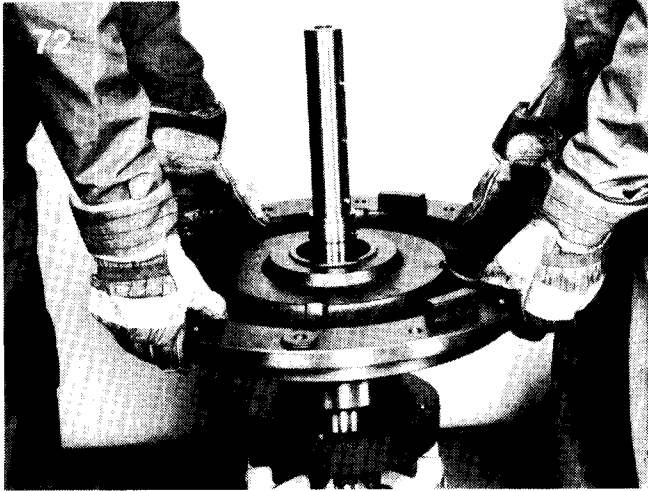
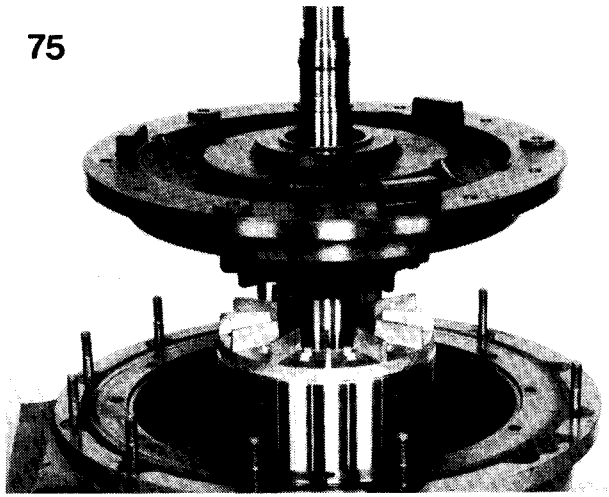

73

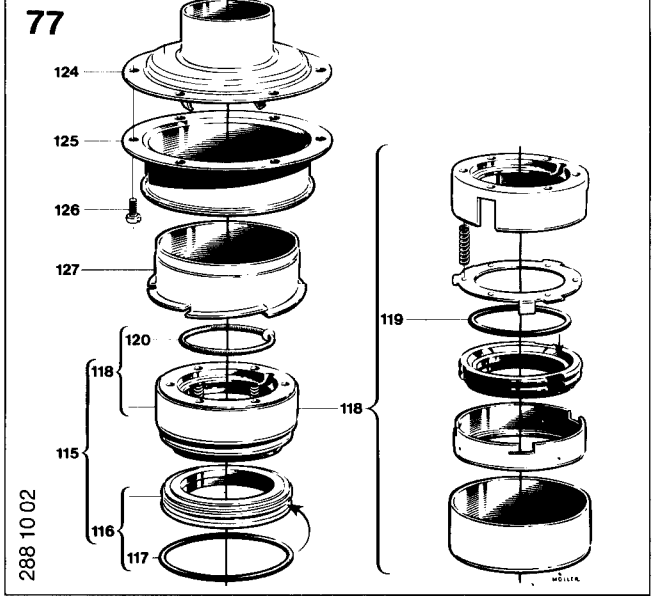
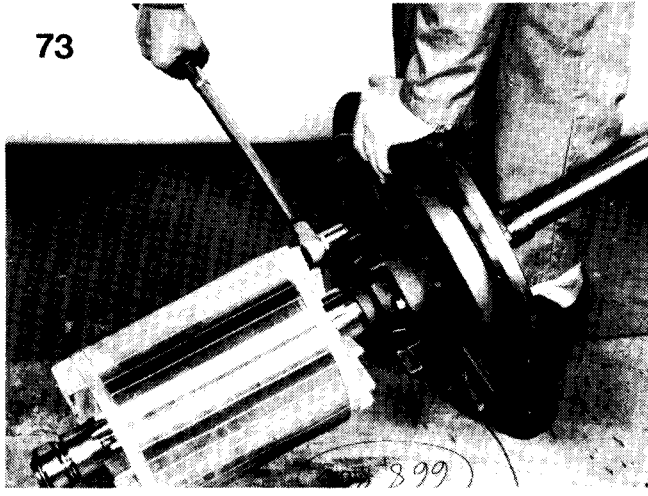

74



78

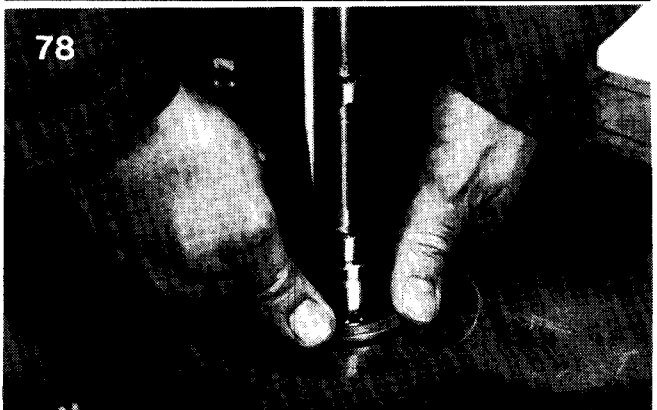

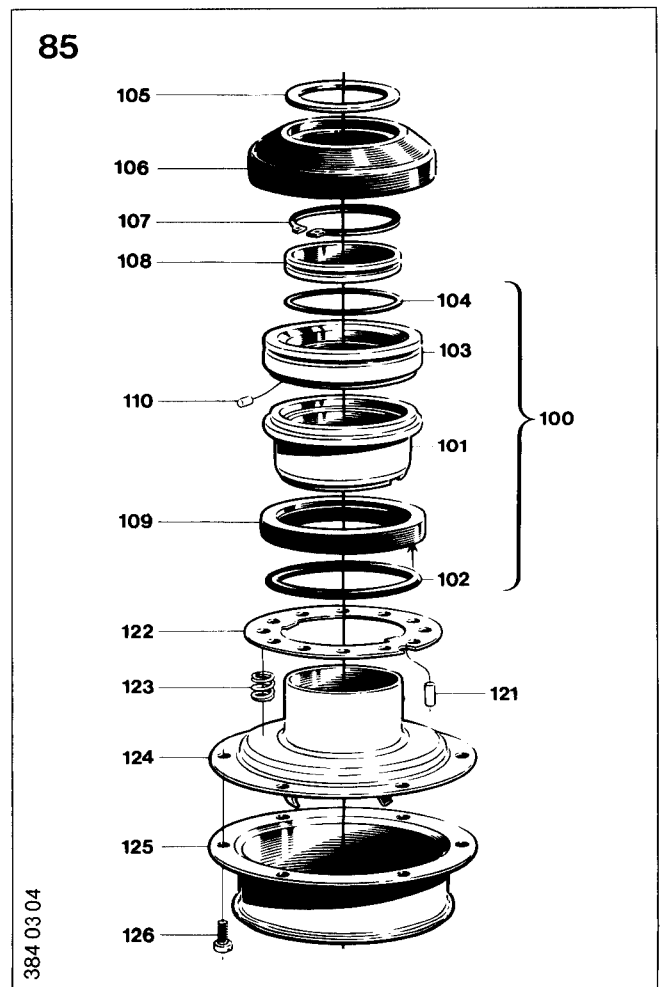
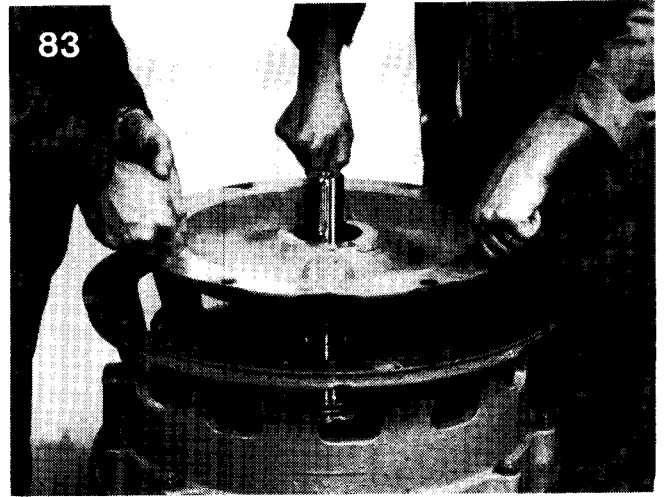
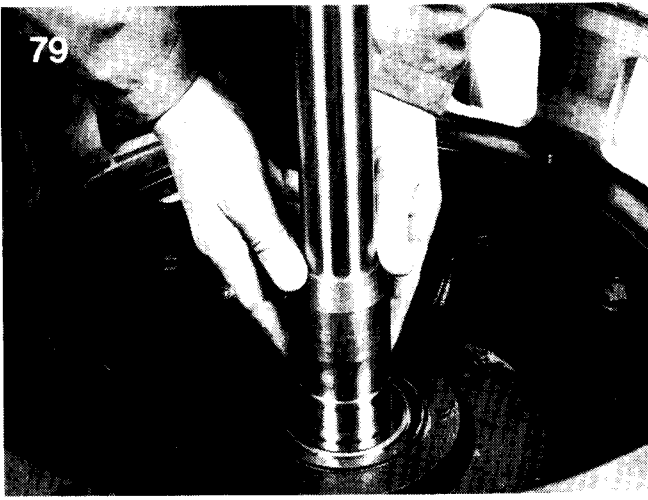

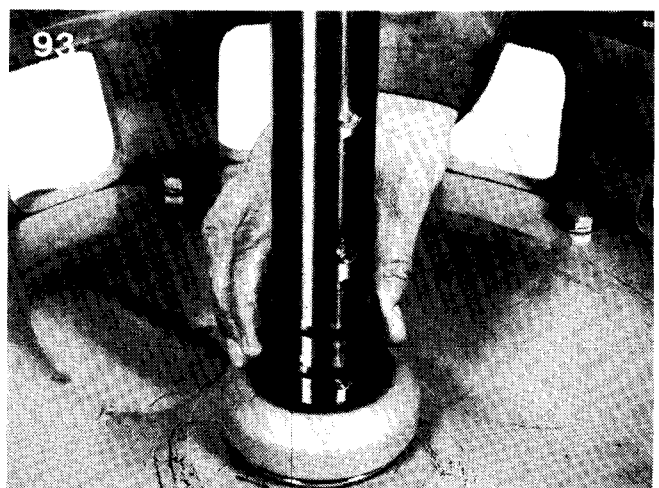
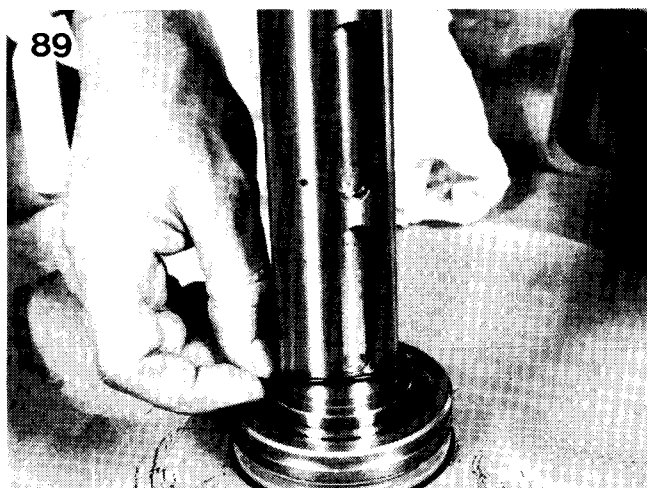
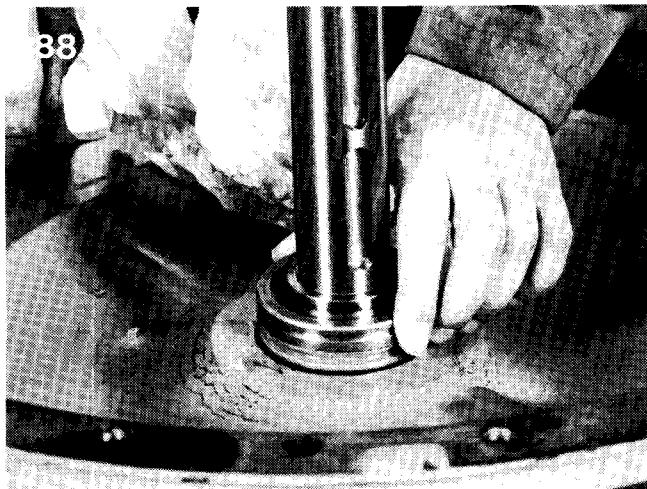
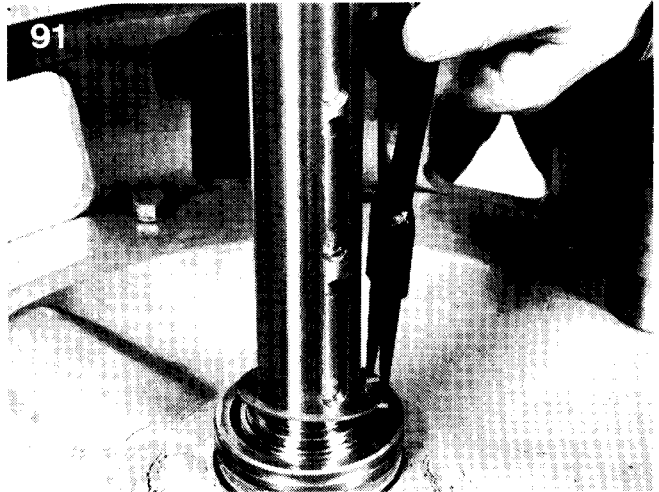
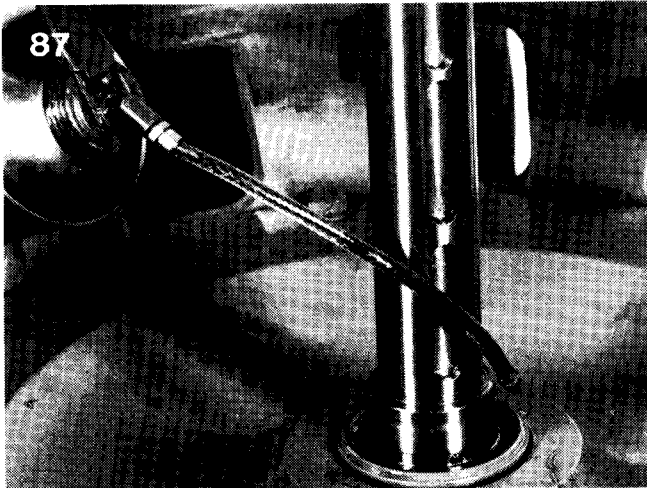
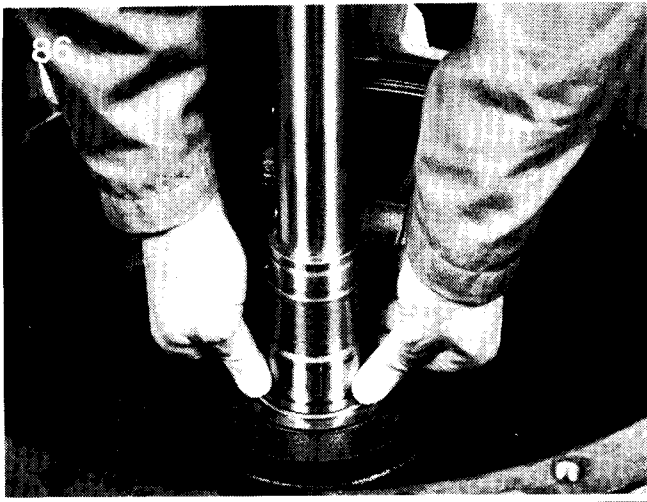

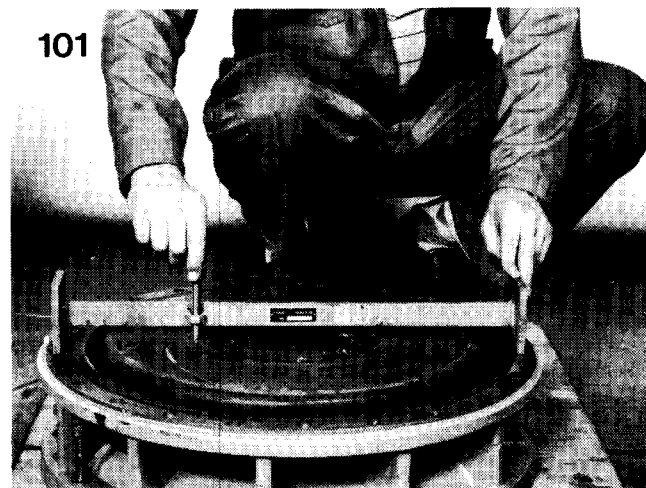
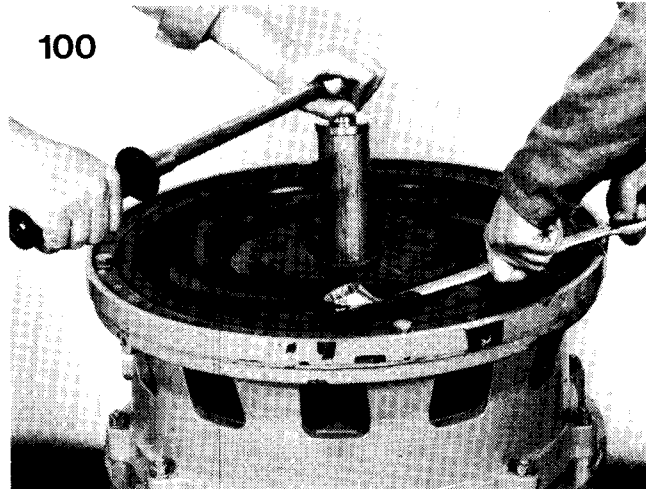
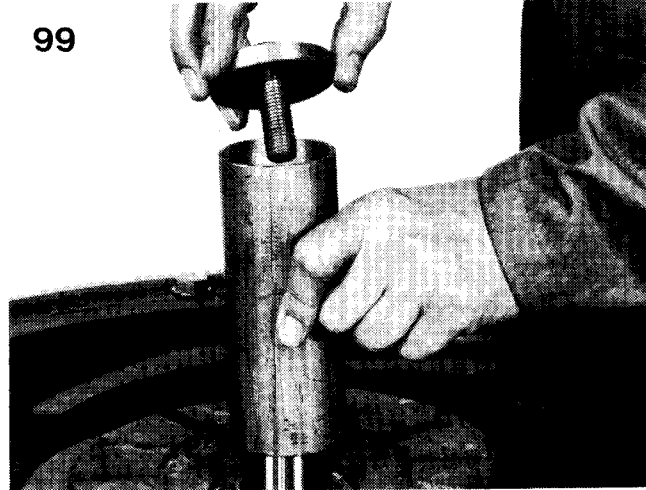
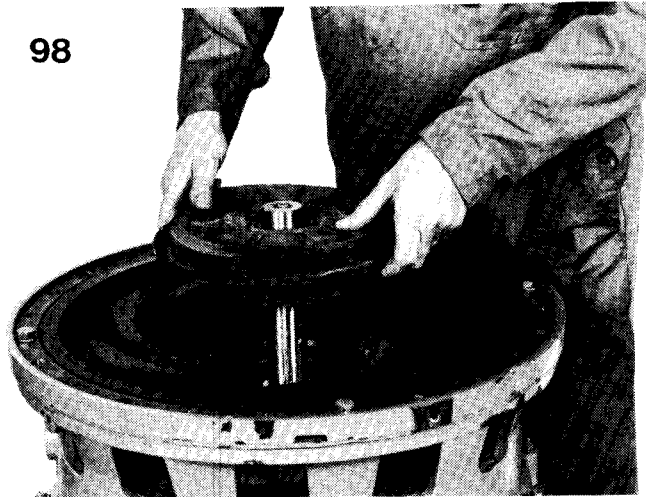
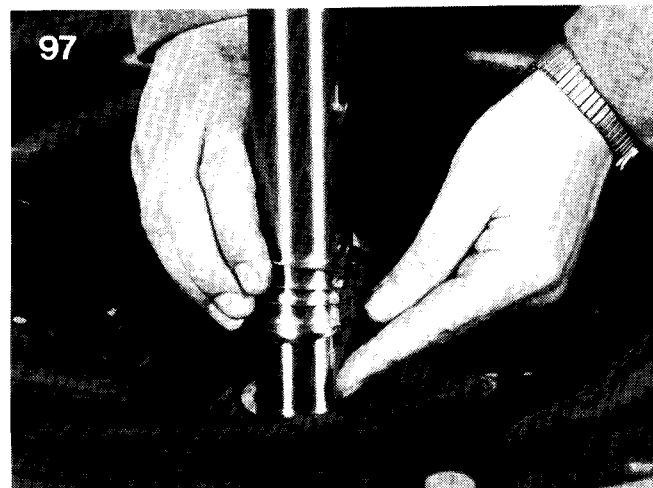
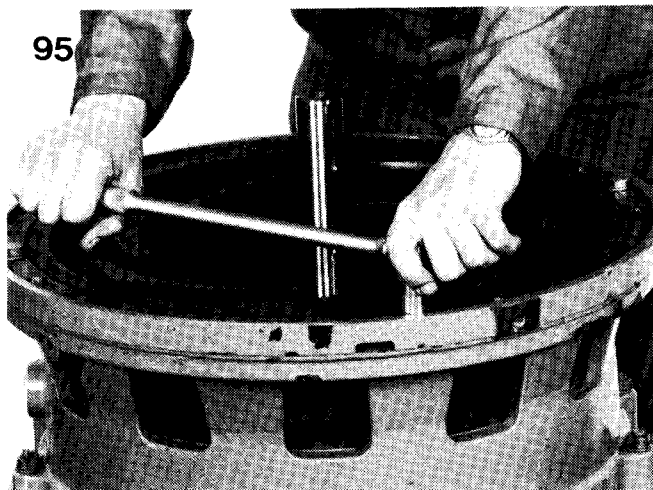
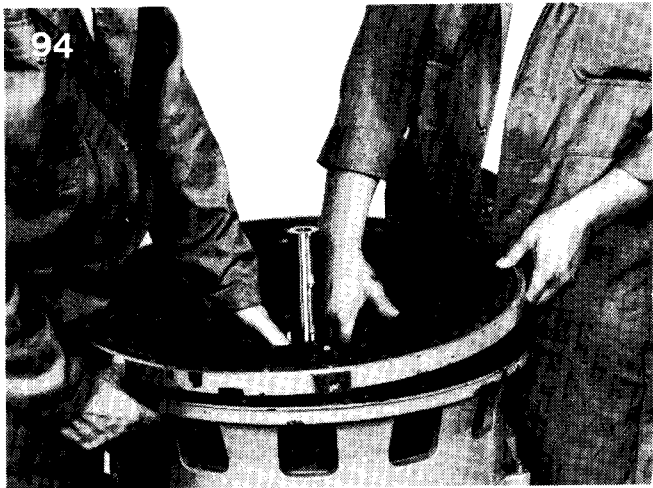

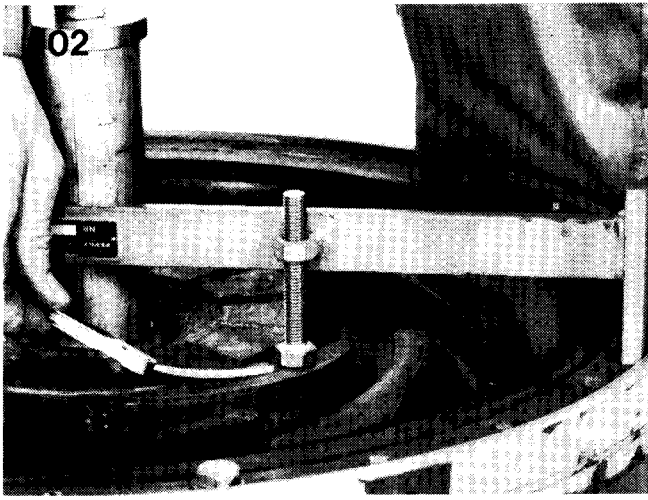

106



103

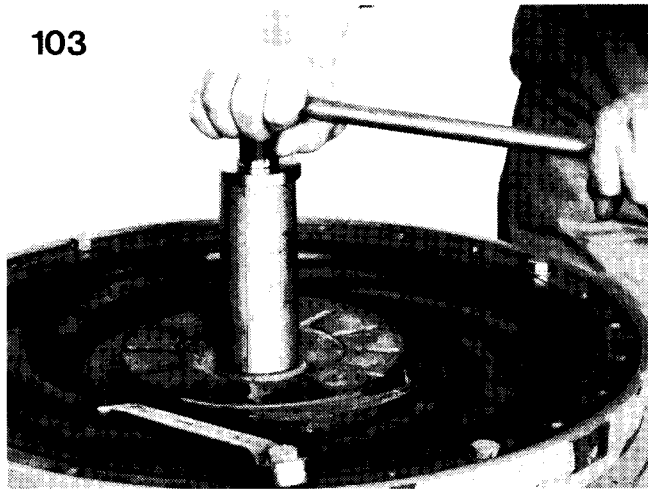

107

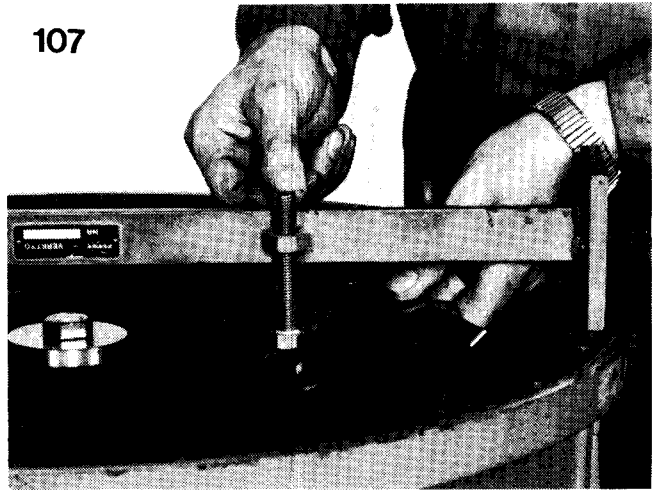

104



108

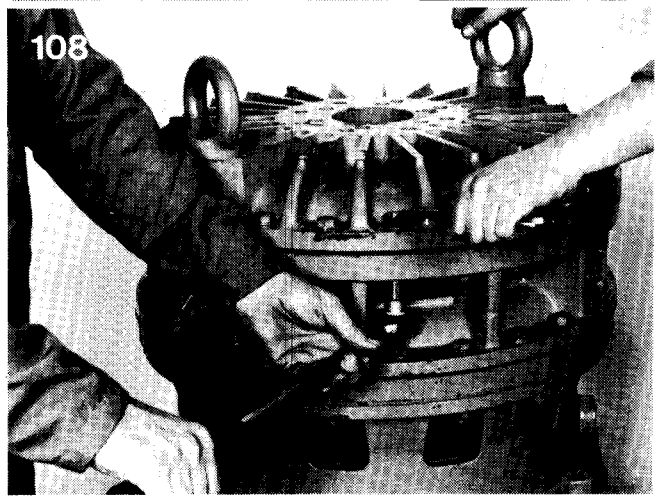

105



109

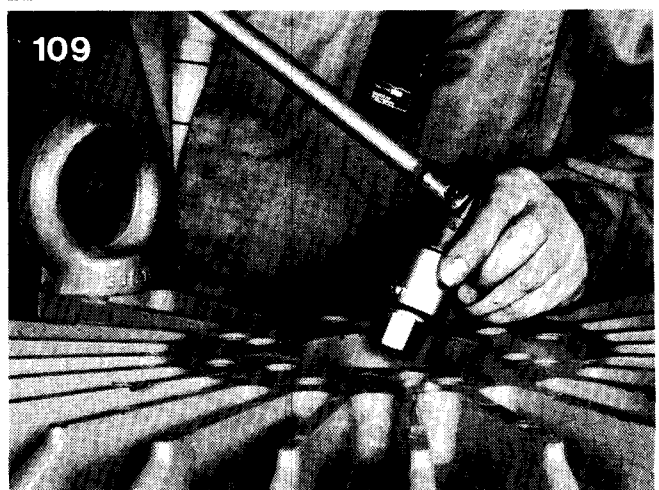

110

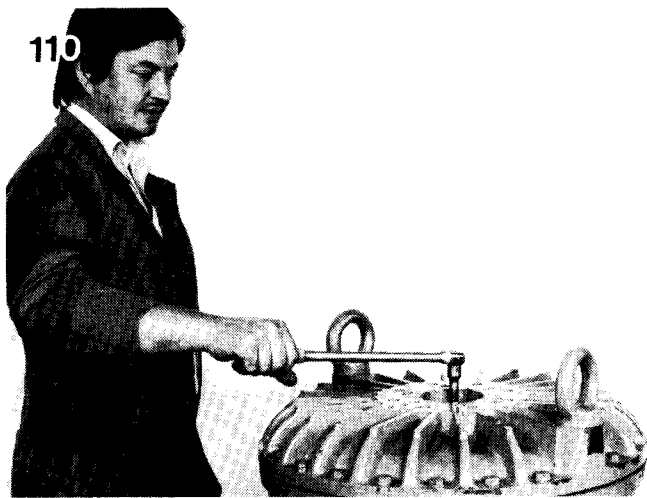

114



111

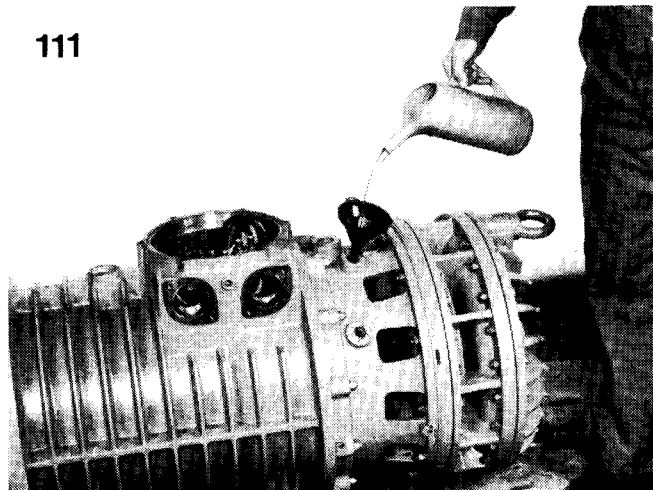

115

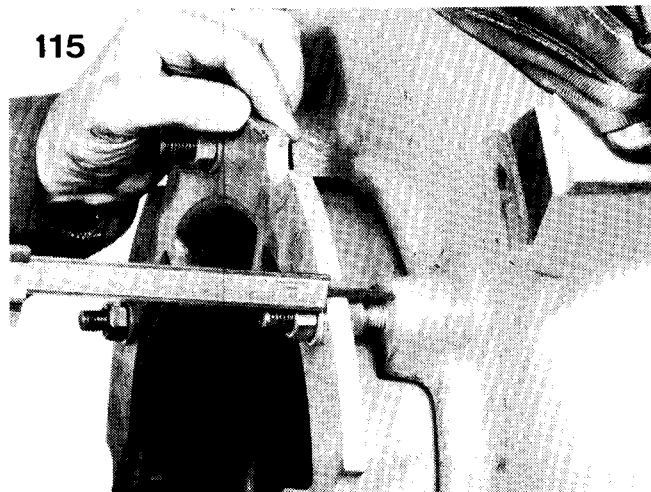

112

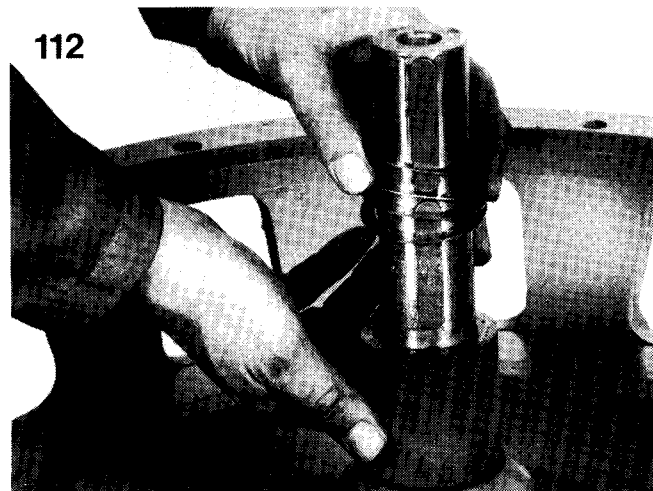

116



113

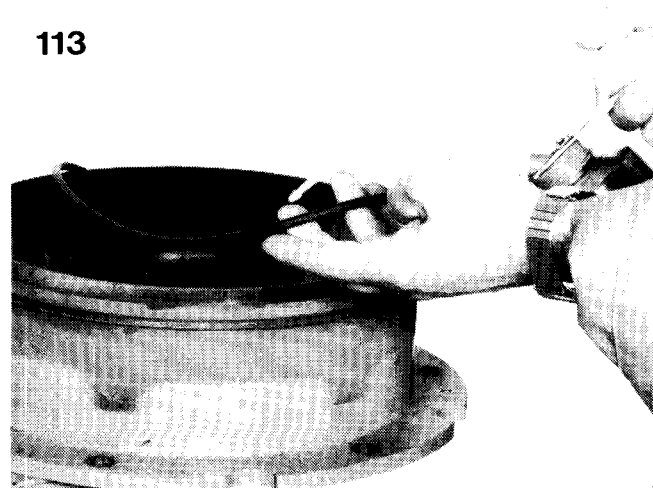

117

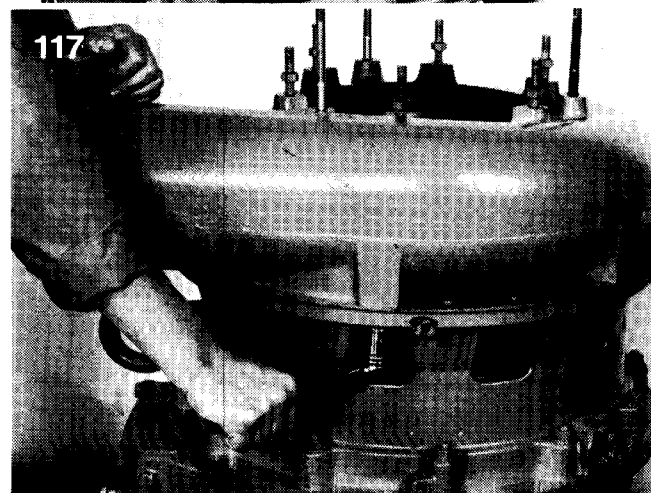

118

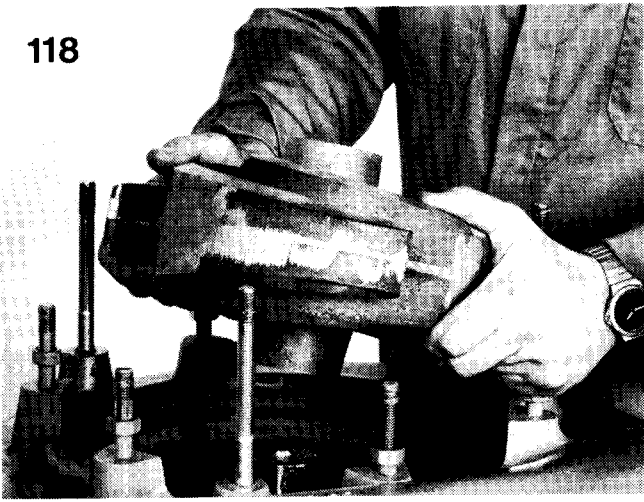

122

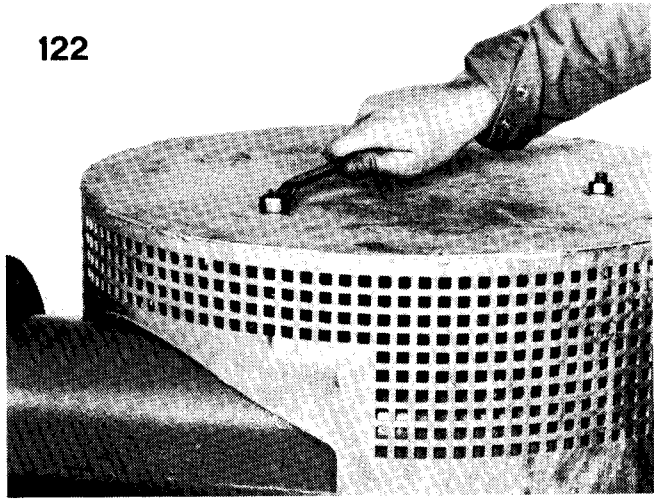

119

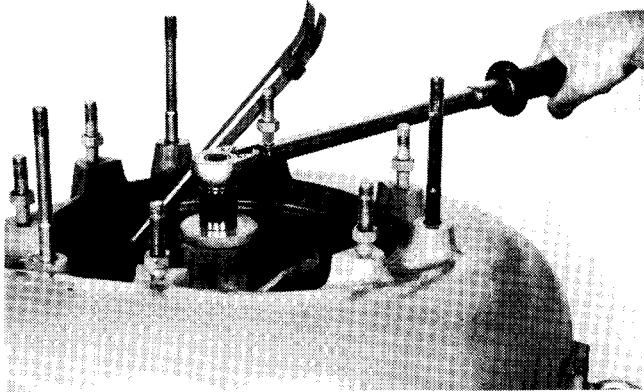

123

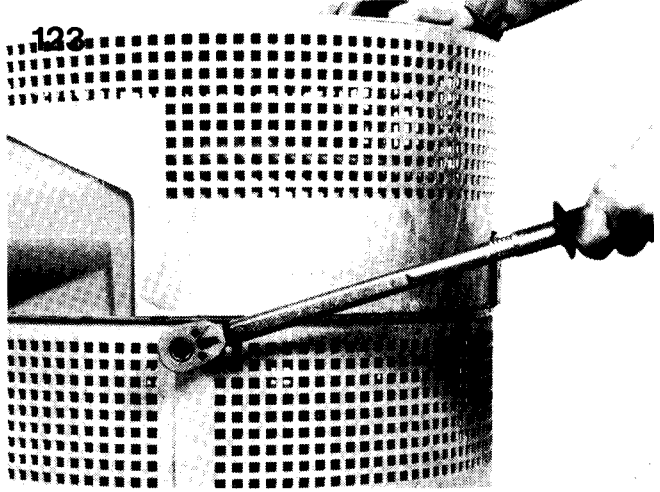

120

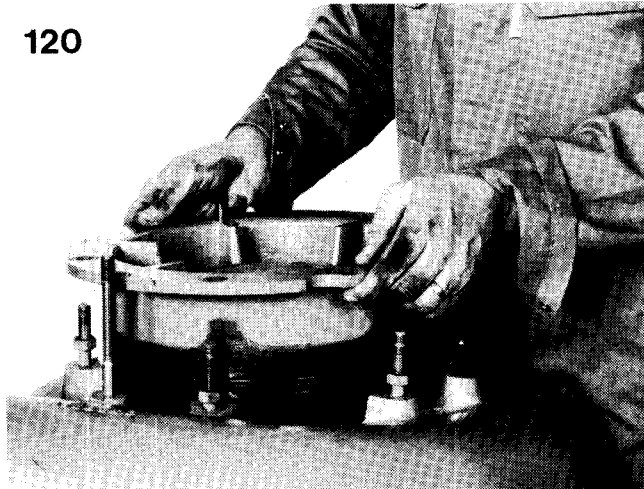

124

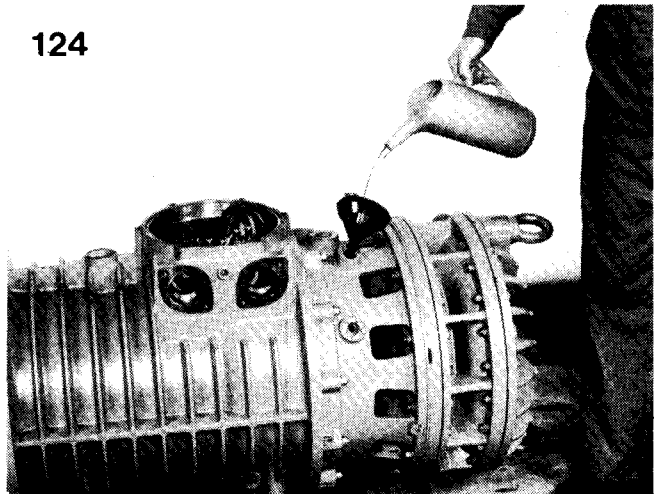

121

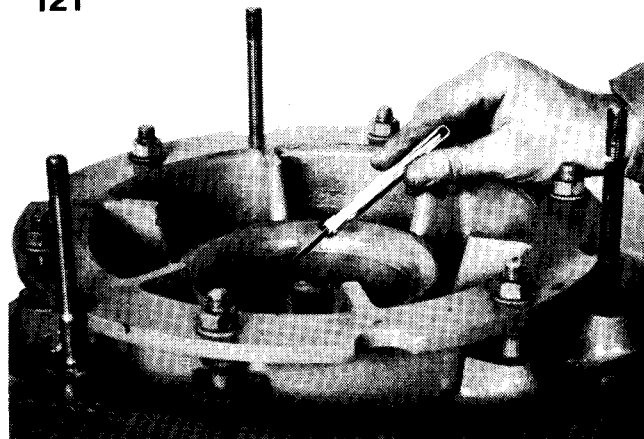

Hydraulic section HT Disassembly

- 1 Remove the six screws on the junction box cover and prize off the cover. Note the O-ring.
- 2 Remove the four screws on the suction strainer, the lifting eye and remove the strainer halves.
- 3 Put the lifting eye back and lift the pump in a sling high enough to place a vessel underneath the pump.
Place a suitable vessel (to hold about 11.5 litres (12 US quarts) of oil) underneath the pump.
Remove the filler plug but hold a rag over the plug before removing it in case the oil in the oil casing is under pressure due to a leaking outer seal.
Remove the drain plug and let all the oil run out. Put back the plug with a new O-ring on it and tighten it. Tightening torque 20 Nm (15 ft lb).
- 4 Mark all main units to be taken apart, for example with a punch.
- 5 Remove the diffuser (22 bolts with nuts).
- 6 Remove the diffuser disc (six screws).
- 7 Fit — if necessary — a new diffuser disc and tighten the screws to 25 Nm (18 ft lb).
- 8 Lock the impeller with e.g. a wrench and screw in the flange and remove the impeller screw with washer.
- 9 Prize off the impeller with the aid of two crowbars, with the support of e.g. sockets (or use a suitable puller).
- 10 Lift off the impeller — remove the washers and knock out the key.
- 11 Remove the diffuser (22 bolts of which every other one is threaded into the casing, every other has a nut).
12. Note: The diffuser separates at the top.
- 13 Prize up the edge of the wear ring in the diffuser and remove the wear ring.
- 14, 15 Remove the six screws on the diffuser disc and prize it loose.
- 16 Fit a new diffuser disc and tighten to 25 Nm (18 ft lb).
17. Press in a new wear ring.
- 18 Remove the sleeve. Note! The upper part is of silicon carbide (grey) and shall face up.
- 19 Prize up the impeller (or use a suitable puller) — remove shims and shaft key.
- 20 Prize loose and remove the diffuser.
21. Knock out the wear ring.
22. Fit a new wear ring.

Hydraulic section MT Disassembly

- 23 Remove the strainers.
- 3 Drain the oil, see HT.
- 24 Remove the outer suction cover (six bolts). Prize loose or use adjusting nuts as puller.
25. Note the O-ring.
- 26 Lock the impeller against the pump casing outlet and remove the impeller screw and washer.
27. If necessary, fit puller 84 13 63 and pull off the impeller.
- 28, 29. Remove the pump casing (six bolts)
- 30, 31. Remove the inner suction cover (six bolts). Prize loose or use the adjusting nuts as pullers.
Note the O-ring.
32. Remove the shaft key, the shims and the sleeve.

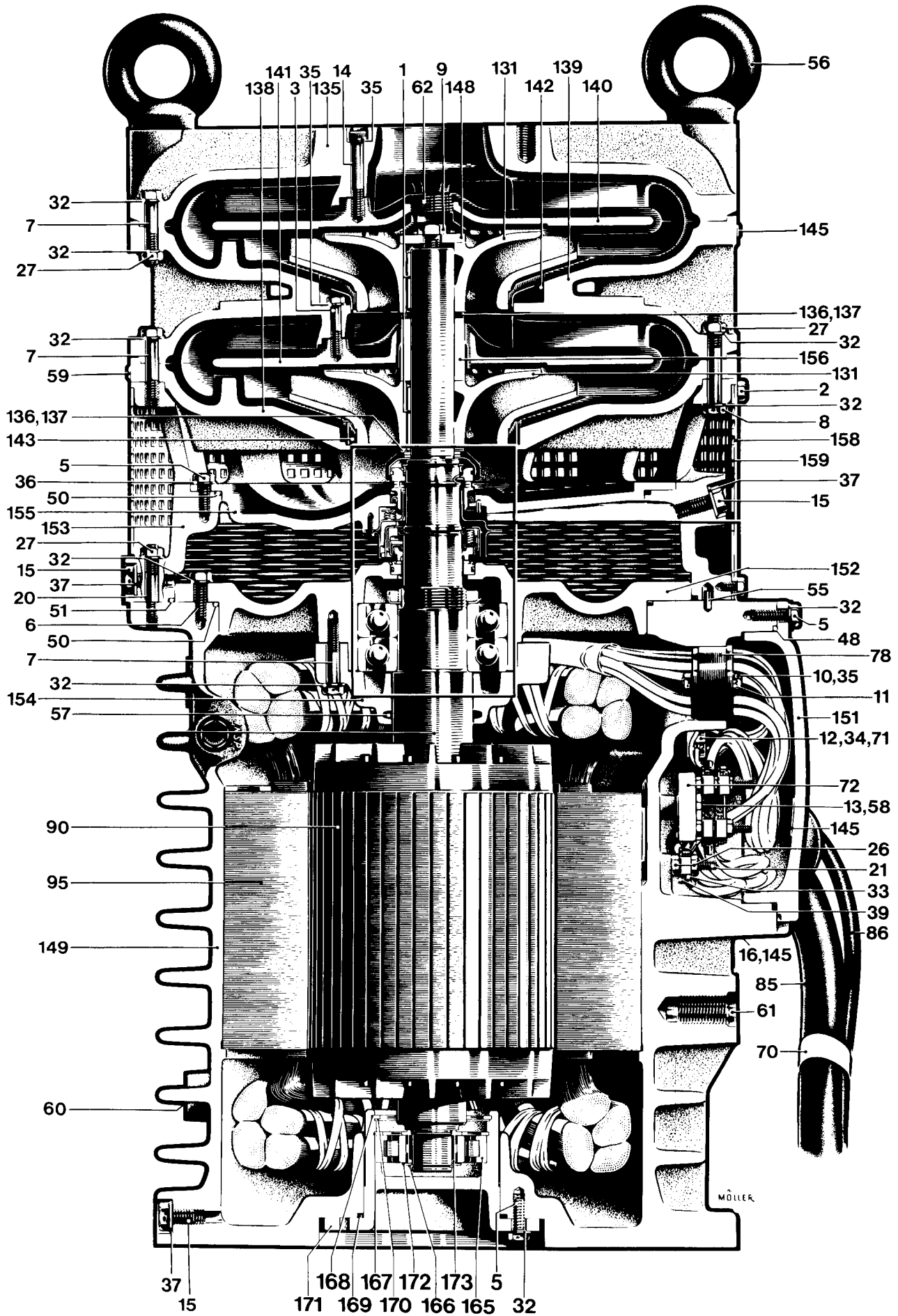

Drive section, HT and MT Disassembly

(see also the exploded drawings for the mechanical seals 77, 85).

33. Remove the spacer washers and the wear protection for the outer seal.
34. Remove the retaining ring.
35. Remove the ring — prize carefully in the groove. Note the location, the shorter groove part shall face up.
36. Prize up the rotating seal ring. Prize in the groove, never between the sealing surfaces. Remove the O-ring.
37. Remove the stationary seal ring.
38. Remove the six screws on the oil casing cover — insert three splitting screws and pull off the cover. Note the O-ring.
- 39, 40. Remove — if necessary — the spring housing for the outer seal.
41. Remove the O-ring — clean the groove and other surfaces — check the replaceable wear cover, replace it if necessary.
42. Remove the inner seal by pushing down the spring housing — grip hold of the locking spring eyes with tool 332 91 00 and carefully pull up the locking spring.
43. Pull up the inner mechanical seal.
44. Remove the stationary seal ring.
- 45, 46. Remove the oil casing (12 studs). Note the O-ring.
47. Remove the 12 screws on the lower bearing housing — fit a lifting eye (M16) in the motor shaft.
48. Rotate the shaft by hand and lift away the unit.
- 49, 50. Remove the four screws on the bearing cover — raise the unit in the lifting eye and block up under the rotor.
51. Fit 3 lifting eyes to the bearing housing and lift it away. Note the O-ring. A few light taps on the shaft end with a plastic/lead mallet may sometimes be required.
52. Knock out the lock tab on the lock washer.
53. Remove the ring nut with a hook wrench — remove the lock washer.
- 54, 55. Rig up the hydraulic puller on the bearing cover — see figure and picture — and pump carefully until the bearings have been pulled off.
Remove the bearings and bearing cover.
Warning! Wear safety goggles — risk of oil splatter .
56. Remove the lock ring and washer for the roller bearing's inner race.
57. Fit a puller and pull off the bearing inner race.
Note! The sleeve (located between the inner race and the shaft) shall not be removed. If it comes off, replace it with a new one.
58. Lay down the stator casing and remove the 4 screws for the roller bearing housing — insert 2 splitting screws and loosen the bearing housing.
59. Pull out the bearing housing. Note the O-ring.
60. Remove the outer retaining ring — and the washer.
61. Remove the inner retaining ring.
62. Remove the roller bearing with puller 84 20 51 + 84 20 50 or another suitable puller.

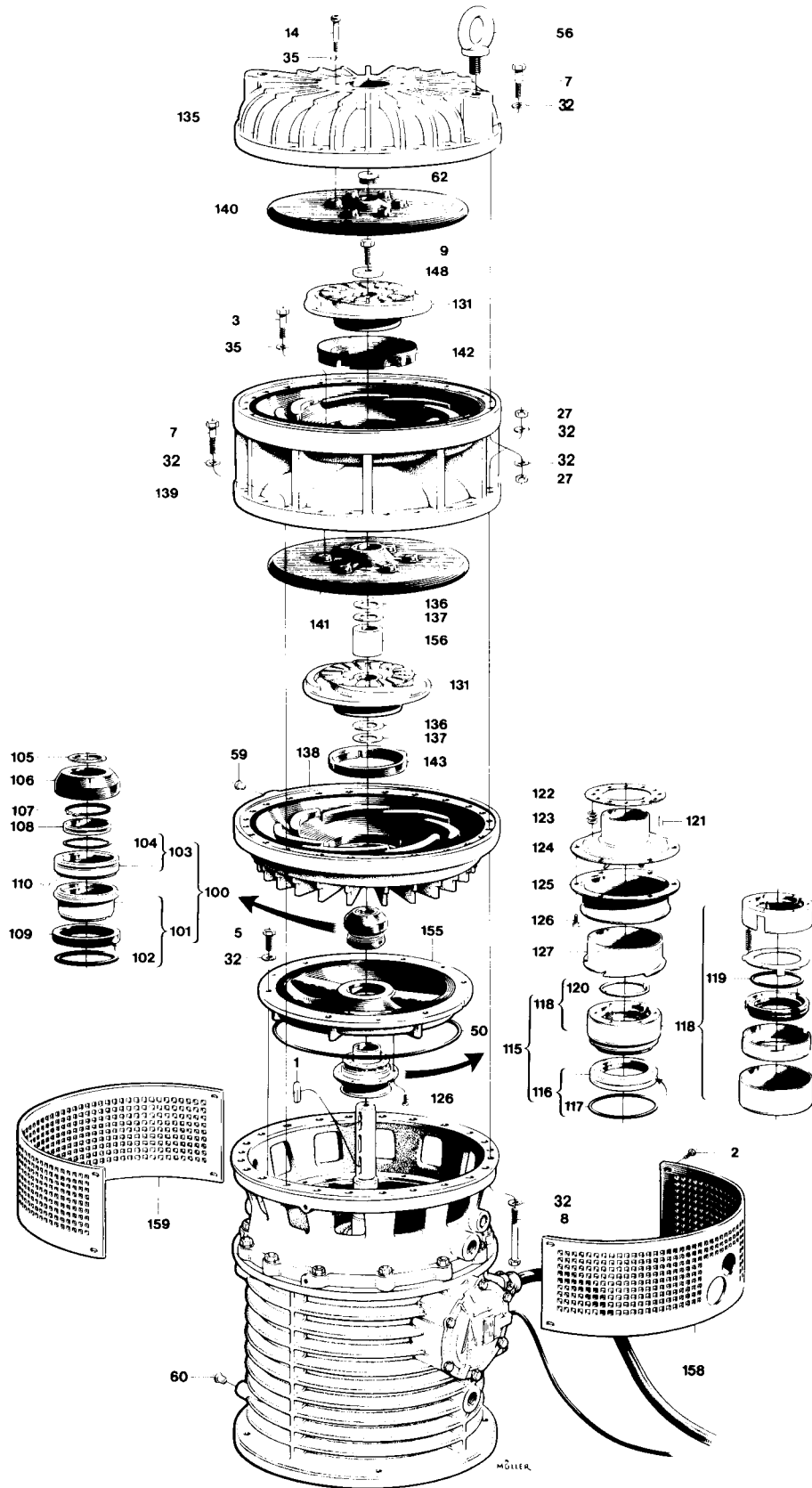

Replacing the stator

Terminal boards.

63. Disconnect the stator leads from the main terminal board and the thermal protector leads from the small terminal board. Loosen the centre screw in the stator lead rubber bushing. Take out the two small screws holding the bushing and pull it off from the stator leads. Pull the leads into the stator casing. Remove the two inspection screws and their O-rings from the stator casing.

Stator

64. Use the special lifting tool 394 70 00 when replacing the stator.
- Place the tool inside the stator core and expand it by turning the centre rod clockwise. The tool should grip in the upper half of the stator. Tighten the rod firmly to ensure a good grip of the tool.
- Lift the stator casing (with stator) up about one inch above the floor with the aid of the stator lifter. Heat the casing rapidly with LP-gas burners to about 150°C (300°F). Concentrate the heat where the stator is seated. When the casing drops to the floor quickly lift the stator out of the casing. Fit the new stator while the stator casing is still hot.
- NOTE: There is a pin that prevents the stator from rotating. Make sure that it fits into the groove in the stator casing.
- Put back the two inspection screws with new O-rings. Tightening torque 20 Nm (15 ft lb).
- IMPORTANT!** If the stator has been rewound, it should have been high voltage tested before the installation. Testing voltage should be twice the rated voltage of the stator + 1000 V.
- Measure the insulation resistance between all the three phases and between the phases and earth with a megger. The reading should be infinity.

Drive section, HT and MT Assembly

65. Heat the bearing housing and fit the roller bearing (always change the inner race and the bearing at the same time).
66. Fit the inner retaining ring — grease the bearing, about 50 g plus about 200 g in the space around the bearing. Put the washer in place and then the outer retaining ring.
67. Fit the roller bearing housing. Note the O-ring. Tighten to 57 Nm (42 ft lb).
- 68, 69. Check the condition of the felt strip in the groove of the bearing cover (Only 402/421). If necessary replace it. Fit a new rubber lip seal ring on to the cover.
- Place the bearing cover on the rotor shaft.
- Extremely important:** Before sliding the bearings on to the shaft observe the correct way of fitting them. The bearings should be mounted back-to-back.
- Heat the bearings to max. 110°C = 230°F and slide them on the shaft.
70. Fit and tighten the shaft nut without the lock washer. Retighten when the bearings have cooled down. Then remove the shaft nut once again and put the locking washer in place. Fit the nut, tighten slightly and bend up a suitable lock-tab on the washer. Grease the bearings, about 60 g on each bearing and about 100 g in the space above and below each bearing.
- 71, 72. Heat the bearing housing slightly and fit it on the main bearings.
73. Tighten the screws holding the bearing cover to 57 Nm (42 ft lb).
74. Check if the sleeve is in place on the shaft. If not, slightly heat a new sleeve and slide it on to the shaft end. Slightly heat the roller bearing race and slide it on to the shaft end. Fit the washer and retaining ring.
75. Lower the rotor assembly into the stator casing. Note the O-ring. Rotate the shaft not to damage the bottom roller bearing. Tighten the screws to 57 Nm (42 ft lb).
76. Fit the oil casing — Note the guide pin and the O-ring. Tighten to 57 Nm (42 ft lb).
77. Seal unit, inner (288 10 02).

2400 MT

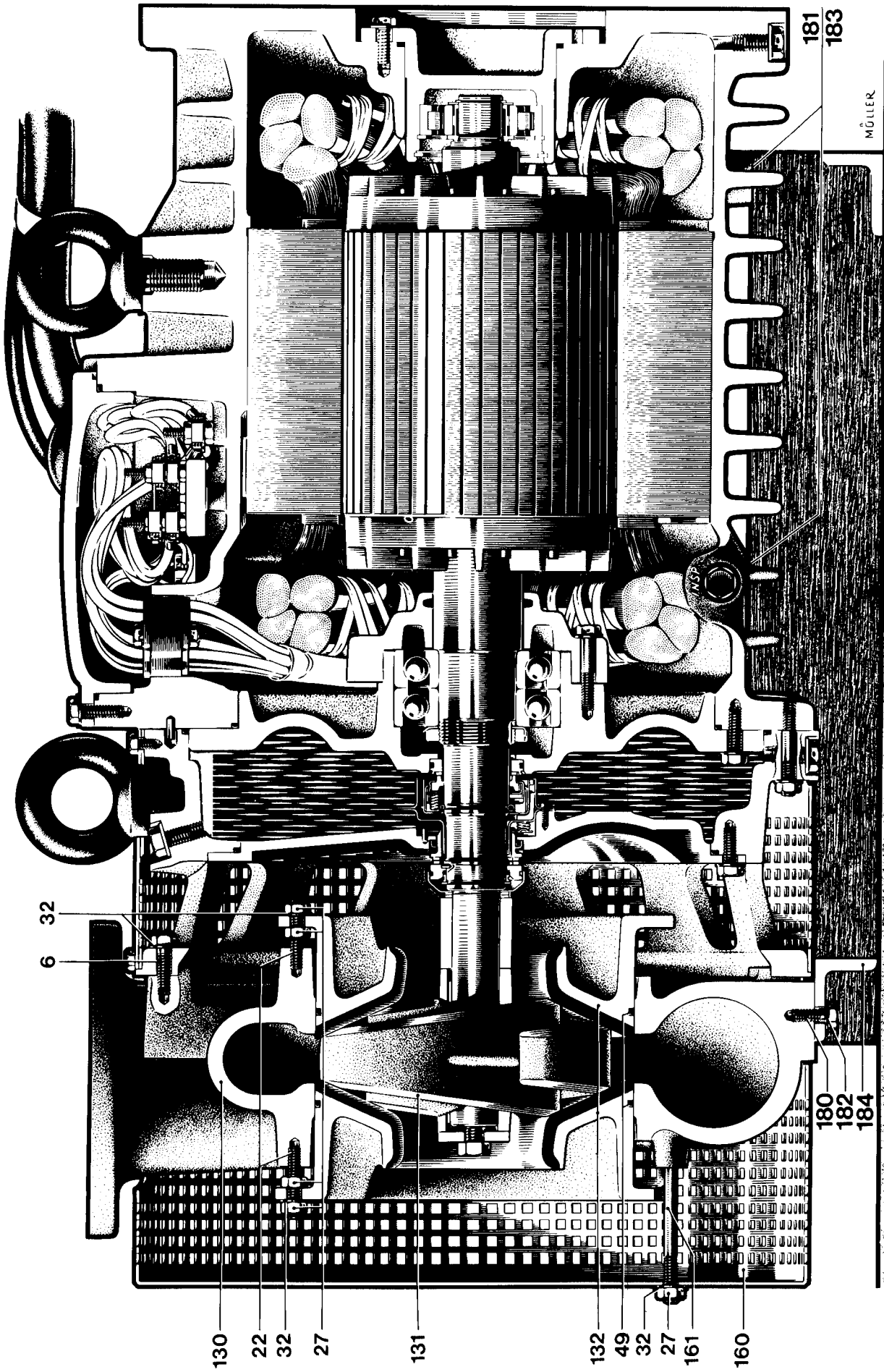

78. Oil or grease the O-ring on the stationary seal ring and press it down by hand.
79. Put assembly sleeve 398 53 00 on the shaft - oil the sleeve.
80. Check that the seal ring surfaces are clean. Oil the seal assembly including the seal ring surfaces and press it down against the stationary seal ring.
81. Note that the recess in the seal assembly (for the ball on the stop spring) lines up with the recess in the shaft. Place the stop spring on the sleeve.
82. Press the spring into position with assembly sleeve 398 54 00.
83. Fit the oil housing cover. Note the O-ring. If preferred, fresh oil should at this point be filled into the oil housing (up to the oil level screw), before the cover is fitted.
84. Rotate the shaft and check that the oil pump impeller runs freely and no scraping sound is heard.
85. Seal unit, outer (384 03 04)
86. Oil and press in the stationary ring. Press and turn until a clicking sound is heard.
87. Oil the sealing surface.
88. Fit the rotating seal ring. Note the pin on the shaft.
- 89, 90. Oil the groove — fit the O-ring and then press in the ring (groove up) with the aid of sleeve 398 53 00.
- 91, 92. Fit the retaining ring — press it down into position with a screwdriver or a sleeve.
93. Fit the protection cover and the spacer washers.

Hydraulic section HT Assembly

- 94, 95. Lift on the lower diffuser, screw in and tighten 4 screws temporarily.
- 96, 97. Fit the shaft key in the lower keyway and put on the shims (7).
98. Apply Thread EZE A or Iloform BWN 205 to the shaft with a brush. Fit the impeller.
99. Fit sleeve 398 60 00 to the shaft, then the shaft washer and screw.
100. Lock the impeller and press it down by tightening the shaft screw.
101. Place gauge 400 21 00 on the lower diffuser disc and screw down the screw until it is flush up against the disc.
102. Turn the tool upside down and place it on the lower diffuser. Measure with a feeler gauge between the screw head and the impeller. The right clearance is 0.2—0.4 mm (0.008—0.16 in). Adjust with adjusting washers underneath the impeller to obtain the right clearance.
103. Remove the shaft screw (lock the impeller), washer, sleeve and the temporarily inserted screws.
104. Fit the spacer sleeve with the silicon carbide part (darker part) facing up.
105. Lift on the middle diffuser and tighten the joint to 57 Nm (42 ft lb).
Fit key and washers on the shaft.
106. Put on the upper impeller, washer and shaft screw.
107. Place the gauge on the upper diffuser disc and measure in the same way as before. Adjust the impeller with adjusting washers to the right clearance. Lock the impeller and tighten it to 200 Nm (148 ft lb)
108. Lift on the upper diffuser and tighten to 57 Nm (42 ft lb).
- 109, 110. Remove the plug in the upper diffuser disc. Check with a socket wrench on the shaft screw that the pump shaft can easily be rotated. If not, the impellers are not free-running and have to be readjusted. Finally fit the plug in the upper diffuser disc.
Fit the strainer halves and tighten to 33 Nm (24 ft lb).
111. If it hasn't already been done (see # 83), fill up with fresh oil to the oil level screw.
Place the screw and a new O-ring back in.
Tightening torque 20 Nm (15 ft lb).

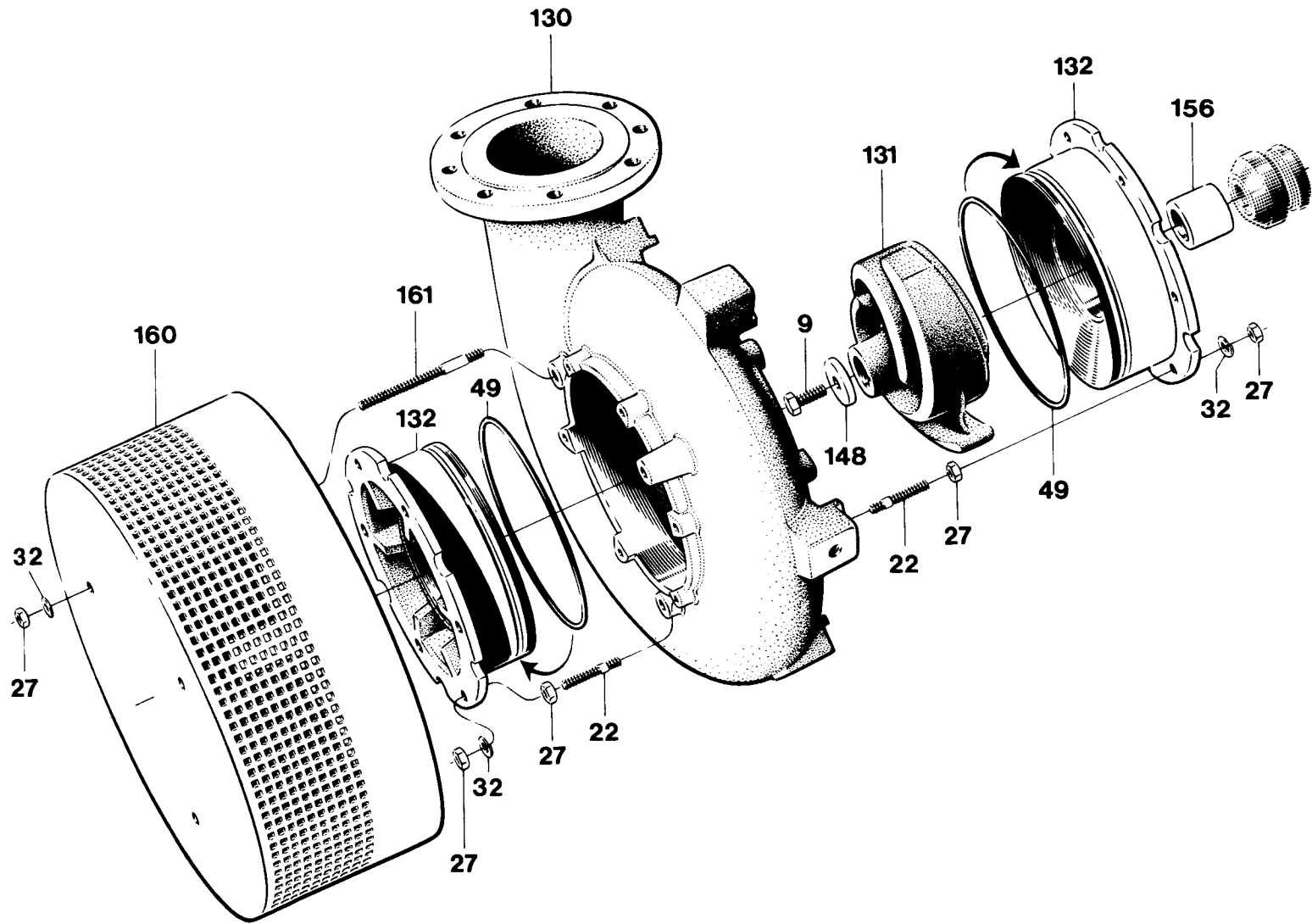

Hydraulic section MT Assembly

112. Fit sleeve, adjusting washers and shaft key.
113. Fit a new, oiled O-ring on the inner suction cover. Clean and oil the suction cover's outer surface.
114. Press the cover into the pump casing to the point where the edge sticks about 2 mm into the casing.
115. Raise the pump casing upright in a sling and make a rough adjustment by measuring that the distance is equal between the flange of the suction cover and the bolt mounts.
116. Lift the pump casing with suction cover.
117. Screw the casing tight — 57 Nm (42 ft lb).
118. Apply Thread EZE A or Iloform BWN 205 to the shaft with a brush. Put on the impeller with the longer hub end facing the motor. Measure the clearance between the impeller vanes and the inner suction cover. It should be approximately 0.2—0.3 mm (0.008—0.012 in) all around. Remove or add an appropriate number of adjusting washers in order to gain the proper clearance.
119. Put the washer and the shaft screw on and tighten the shaft screw to 200 Nm (148 ft lb).
120. Fit a new oiled O-ring on the outer suction cover. Clean and oil the suction cover's outer surface. Press the suction cover into the pump casing against the impeller.
121. Measure the clearance between the impeller vanes and the outer suction cover. It should be approximately 0.2—0.3 mm (0.008—0.012 in) all around. If necessary, adjust with the adjusting nuts and then tighten them.
122. Fit the bottom strainer and tighten (not so hard that the sheet metal is deformed).
123. Fit the strainer halves and tighten to 33 Nm (24 lbf ft).
Regarding oil filling and electrical connections, see HT.
124. Fill up with fresh oil, SAE 10W-30, 11.5 litres (12 US quarts).
Place the screw and a new O-ring back in. Tightening torque 20 Nm (15 lb ft).

Electrical leads

Connect the electrical leads — see the care and maintenance instructions — fit the junction box cover.

Install the motor cable and the control cable.

To avoid leakage into the pump, check:

- that the cable entry seal sleeve and washers conform to the outside diameter of the cable.
See the parts list.
- that the outer jacket on the cable is not damaged. When refitting a cable which has been used before, **always** cut off a short piece of the cable so that the cable entry seal sleeve does not close around the cable at the same point again.

NOTE! For safety reasons, the earth lead should be approx. 100 mm (4.0") longer than the phase leads.

Connect the motor cable to the terminal board connections U1, V1, W1 and earth.

Connect the control leads from the motor control circuit to T1 and T2.

