



Installation, care and maintenance

2102.220



Flygt



GUARANTEE

Flygt undertakes to remedy faults in products sold by Flygt provided:

- that the fault is due to defects in design, materials or workmanship;
- that the fault is reported to Flygt or Flygt's representative during the guarantee period;
- that the product is used only under conditions described in the care and maintenance instructions and in applications for which it is intended;
- that the monitoring equipment incorporated in the product is correctly connected;
- that all service and repair work is done by a workshop authorized by Flygt;
- that genuine Flygt parts are used.

Hence, the guarantee does not cover faults caused by deficient maintenance, improper installation, incorrectly executed repair work or normal wear and tear.

Flygt assumes no liability for either bodily injuries, material damages or economic losses beyond what is stated above.

Flygt guarantees that a spare parts stock will be kept for 10 years after the manufacture of this product has been discontinued.

The manufacturer reserves the right to alter performance, specification or design without notice.

DATA PLATE INTERPRETATION

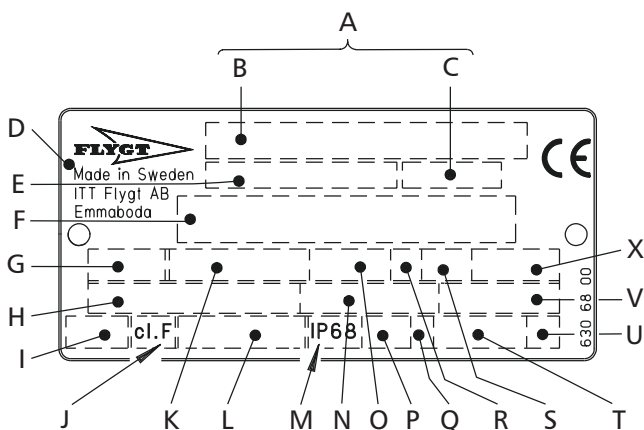

- A Serial number
- B Product code + Number
- C Curve code / Propeller code
- D Country of origin
- E Product number
- F Additional information
- G Phase; Type of current; Frequency
- H Rated voltage
- I Thermal protection
- J Thermal class
- K Rated shaft power
- L International standard
- M Degree of protection
- N Rated current
- O Rated speed
- P Max. submergence
- Q Direction of rotation: L=left, R=right
- R Duty class
- S Duty factor
- T Product weight
- U Locked rotor code letter
- V Power factor
- X Max. ambient temperature

CONTENTS

Product description _____	3	Care and maintenance _____	12
Applications _____	3	Safety precautions _____	12
Motor data _____	3	Inspection _____	12
Dimensions and weights _____	3	Changing the oil _____	14
Materials _____	3	Replacing the impeller _____	15
Performance curves _____	4	Replacing the mechanical seal _____	17
Installation _____	4	Main parts _____	18
Electrical connections _____	5	Service log _____	19
Operation _____	12		

PRODUCT DESCRIPTION

Applications

2102.220 is intended to be used for:

- pumping of water which may contain abrasive particles.

The pump is available in the following versions:

MT = medium-head version

HT = high-head version

Liquid temperature: max. 40°C (105°F).

Liquid density: max. 1100 kg/m³ (9.2 lb per US gal.).

The pumped liquid may contain particles up to a size which corresponds to the openings in the strainer (492 holes @ diameter 8 mm).

The pH of the pumped liquid: 5—8.

Depth of immersion: max. 20 m (65 ft).



WARNING!
The pump may not be used in an explosive or flammable environment or for pumping flammable liquids.

For other applications contact your nearest Flygt representative for information.

Dimensions and weights

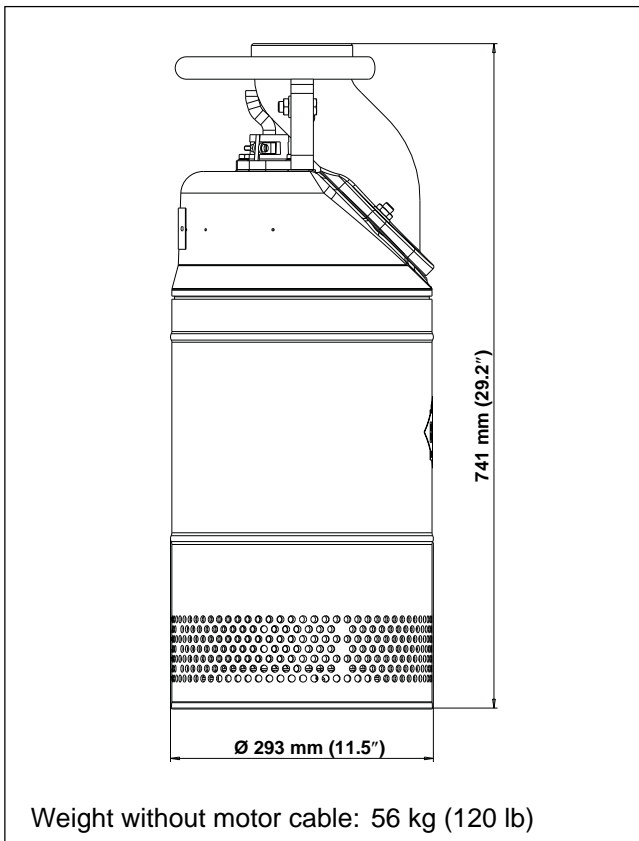

Motor data

Motor type: Squirrel-cage 3-phase induction motor for 50 Hz markets.

2102.220

**Rated output 3.7 kW
3~ 50 Hz, 2800 r/min**

Voltage V	Rated Current A	Starting Current A
400	7.6	40
415	7.1	41
440	6.7	44

**Rated output 5.2 kW
3~ 50 Hz, 2835 r/min**

Voltage V	Rated Current A	Starting Current A
400	10	66
415	10	69
440	9.4	73

Materials

Denomination	Material	EN	ANSI
Major castings:	Aluminium alloy	EN 1706 AC-43100-SF	—
Outer casing, cooling jacket:	Stainless steel	EN 10088-2 — 1.4301	ASTM AISI 304
Lifting bolts:	Galvanised steel	EN 10025 — 1.0038	ASTM A36
Shaft:	Stainless steel	EN 10088-3 — 1.4021	420
Impeller:	High chrome alloyed white cast iron	EN-12513 1996-JN2080	ASTM 532-80 Alloy 111 A
Wear parts:	Nitrile rubber	—	—
Strainer:	Stainless steel	EN 10088-2 — 1.4301	ASTM AISI 304
Bushing for cable entry:	Chloroprene rubber	—	—
Screws, studs and nuts:	Stainless steel	EN 10088-3	313L
O-rings:	Nitrile rubber	—	—
Grease:	Esso Grease Unirex 3	—	—
Mechanical face seals:	Inner rotating ring Outer rotating, Inner & outer stationary rings	Tungsten carbide Tungsten carbide	— —

PERFORMANCE CURVES

Each pump is tested in accordance with ISO 9906.

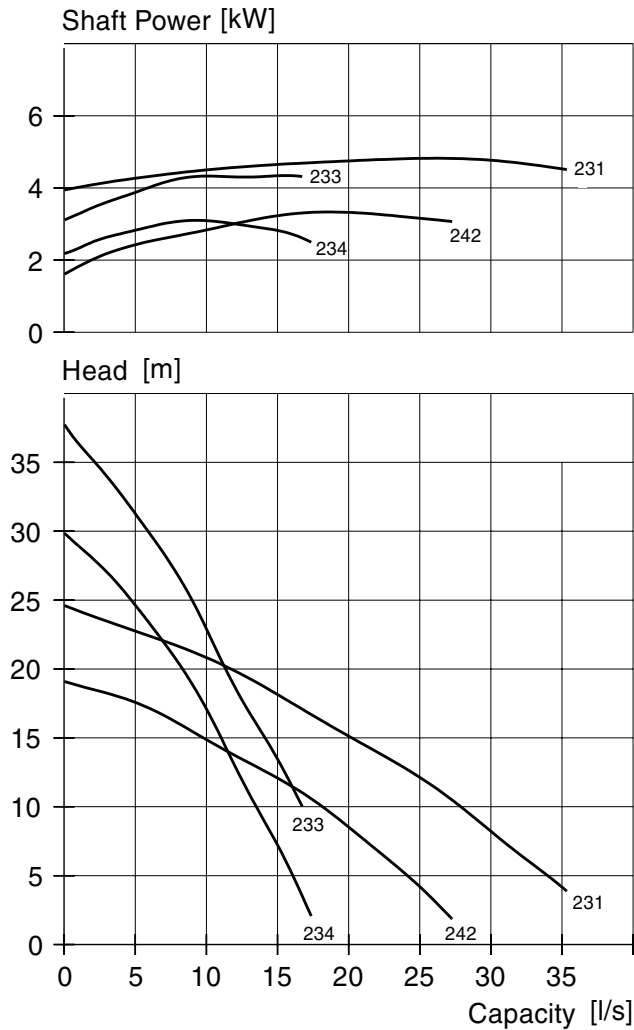

INSTALLATION

Pump installation

Run the cables so that they do not have any sharp bends and are not pinched.

Connect the discharge connection and motor cable. See "Electrical connections".

Lower the pump into the sump.

Place the pump on a base which will prevent it from sinking into a soft sump bottom. Alternatively, the pump can be suspended by its eye-bolts just above the sump bottom.



NOTE!

Where required by local authorities an acceptable motor-circuit switch or other disconnecting device shall be provided at the time of installation.



NOTE!

At certain installations and operation points on the pump curve the noise level 70 dB, or for the actual pump specified noise level, can be exceeded.

ELECTRICAL CONNECTIONS



WARNING!
All electrical equipment must be earthed (grounded). This applies to both pump equipment and any monitoring equipment. Failure to heed this warning may cause a lethal accident. Make sure that the earth (ground) lead is correctly connected by testing it.



NOTE!
Make sure that the monitoring equipment incorporated in the product is correctly connected.

All electrical work shall be carried out under the supervision of an authorized electrician.

Local codes and regulations shall be complied with.

Check that the mains voltage and frequency agree with the specifications on the pump data plate.

NOTE! For safety reasons, the earth (ground) lead should be approx. 70 mm (2¾") longer than the phase leads. If the motor cable is jerked loose by mistake, the earth (ground) lead should be the last lead to come loose from its terminal. This applies to both ends of the cable.

Make sure that the pump is correctly earthed (grounded).

SUBCAB/SUBCAB AWG*:

Mains	Lead	Pump terminal board
L1	Brown (Red*)	U1
L2	Blue (White*)	W1
L3	Black (Black*)	V1
Earth (PE)	Yellow/Green	PE
Groundcheck	Yellow*	GC
T1	Black (Orange*)	T1
T2	Black (Blue*)	T2

The stator leads are colour-marked as follows:

- U1, red
- V1, brown
- W1, yellow
- V2, blue
- W2, black
- U2, green

Connect the control leads from the motor control circuit to T1 and T2.

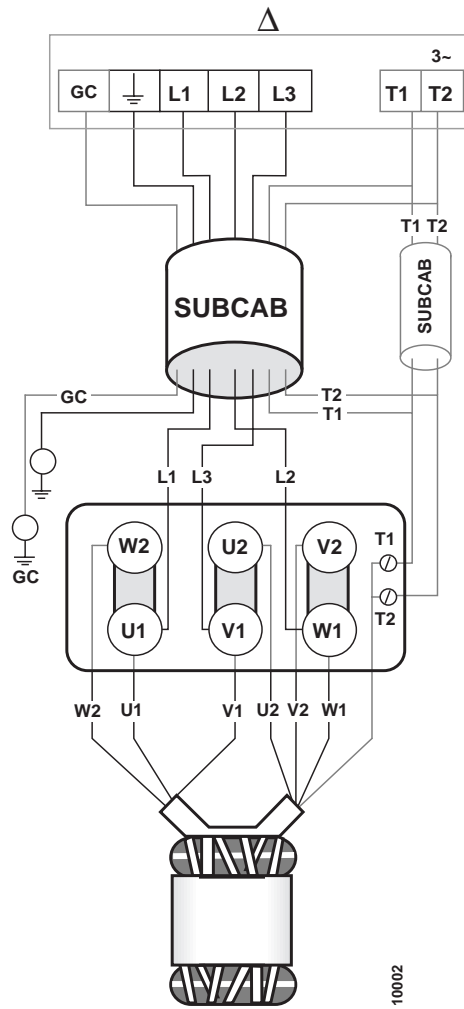
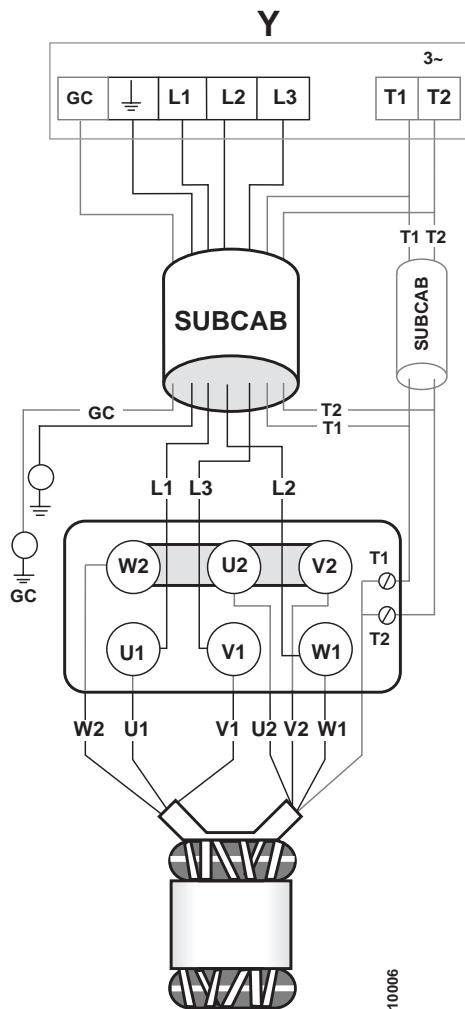

50/60 Hz, 3~ with contactor unit

Connections valid for: **2102.220**

SUBCAB/SUBCAB AWG*

Mains	Lead	Pump contactor
L1	Brown (Red*)	1
L2	Blue (White*)	5
L3	Black (Black*)	3
Earth (PE)	Yellow/Green	PE

The stator leads are colour-marked as follows:

red	— 2	white	— 3
brown	— 4	white	— A2
yellow	— 6		
green	} — separate Y-terminal		
blue			
black			

In the case of delta connection (D), the stator leads are connected to the contactor as follows:

red	} — 2	yellow	} — 6
black		blue	
brown	} — 4	white	— 3
green		white	— A2

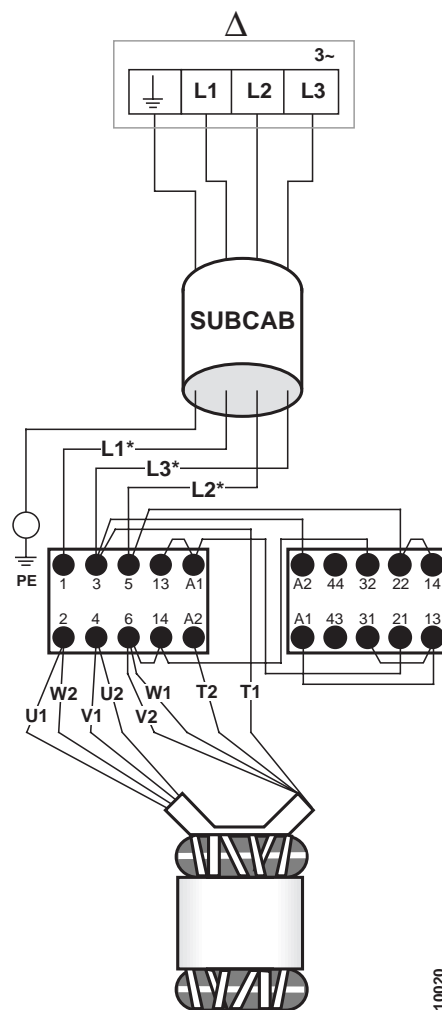
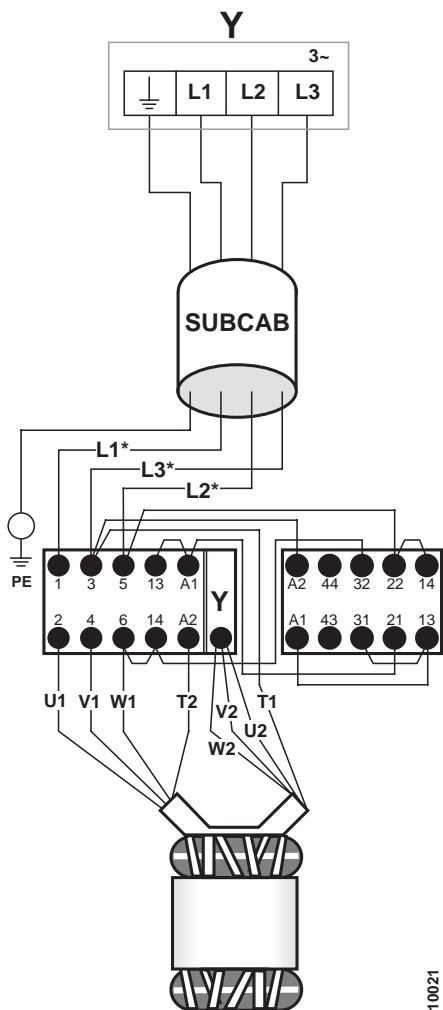

50/60 Hz, 3~ with terminal board

Connections valid for: **2102.220**

SUBCAB/SUBCAB AWG*:

Mains	Lead	Pump terminal board
L1	Brown (Red*)	U1
L2	Blue (White*)	W1
L3	Black (Black*)	V1
Earth (PE)	Yellow/Green	PE
Groundcheck	Yellow*	GC
T1	Black (Orange*)	T1
T2	Black (Blue*)	T2

The stator leads are colour-marked as follows:

- U1, red
- V1, brown
- W1, yellow
- U2, green
- V2, blue
- W2, black
- U5, red
- V5, brown
- W5, yellow

Connect the control leads from the motor control circuit to T1 and T2.

**9-leads
500V Y//
230V Y//**

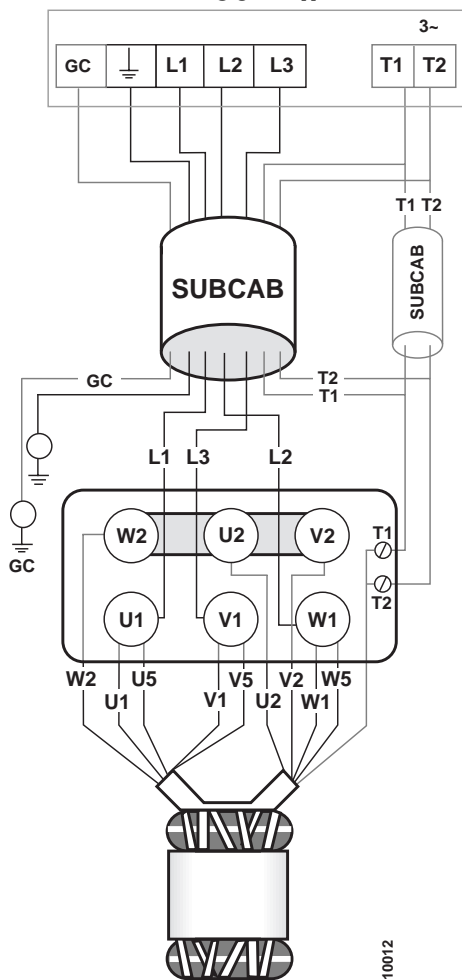

10012

**9-leads
1000V Yser.
460V Yser.**

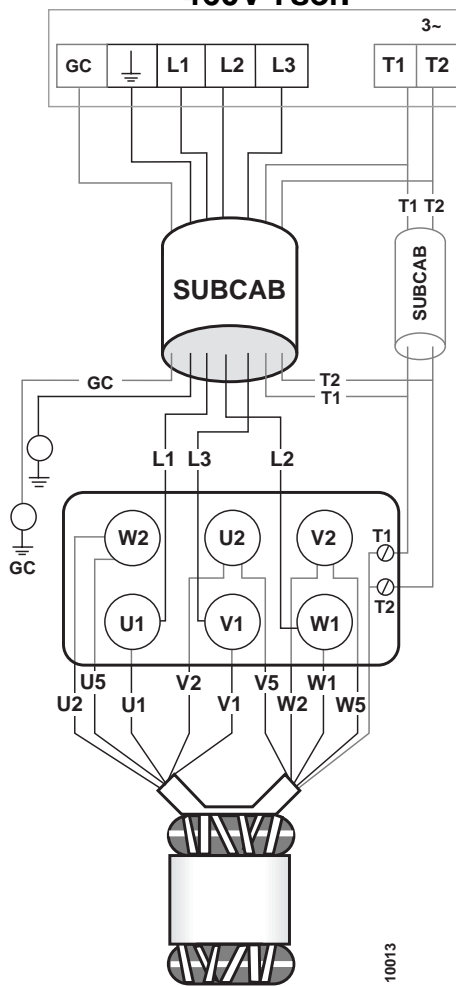

10013

50/60 Hz, 3~ with terminal board

Connections valid for: **2102.220**

SUBCAB/SUBCAB AWG*:

Mains	Lead	Pump terminal board
L1	Brown (Red*)	U1
L2	Blue (White*)	W1
L3	Black (Black*)	V1
Earth (PE)	Yellow/Green	PE
Groundcheck	Yellow*	GC
T1	Black (Orange*)	T1
T2	Black (Blue*)	T2

Connect the control leads from the motor control circuit to T1 and T2.

The stator leads are colour-marked as follows:

- U1, red
- V1, brown
- W1, yellow
- U2, green
- V2, blue
- W2, black
- U5, red
- V5, brown
- W5, yellow
- U6, green
- V6, blue
- W6, black

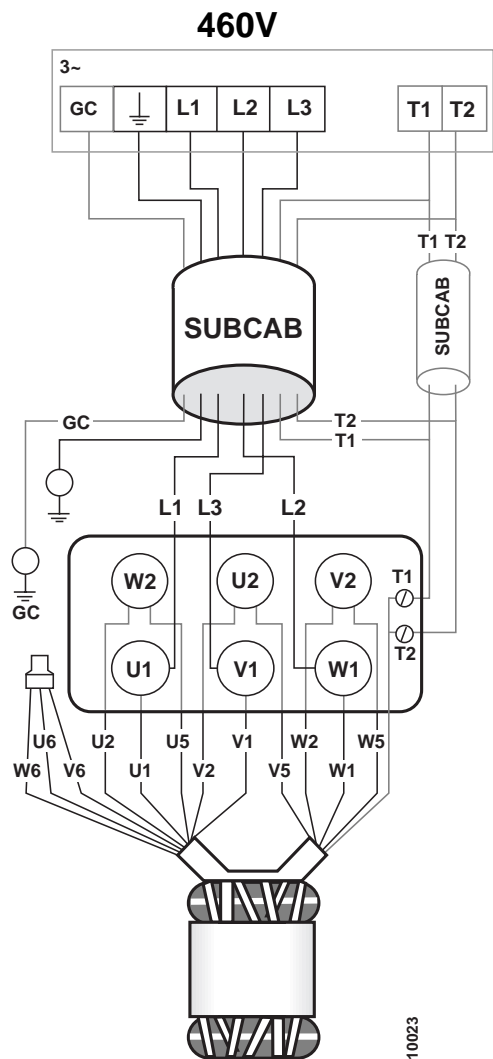
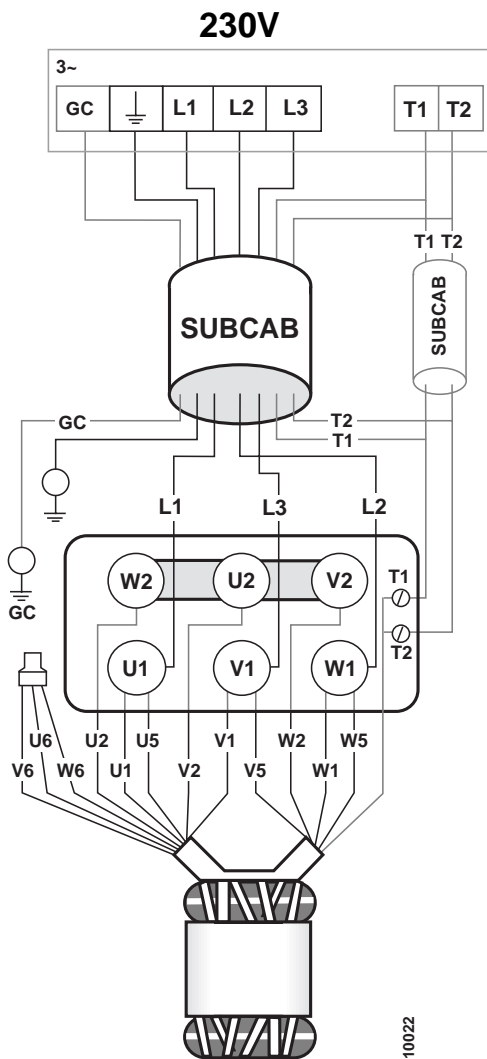

60 Hz, 1~ with terminal board

Connections valid for: **2102.220**

SUBCAB/SUBCAB AWG*:

Mains	Lead	Pump terminal board
1	Brown (Red*)	U1
2	Black (Black*)	V1
3	Blue (White*)	W1
Earth (PE)	Yellow/Green	PE

The stator leads are colour-marked as follows:

- U1, red
- V1, brown
- W1, yellow
- U2, green
- V2, blue
- W2, black
- U5, red
- V5, brown
- W5, yellow
- U6, green
- V6, blue
- W6, black

**12-leads
230V**

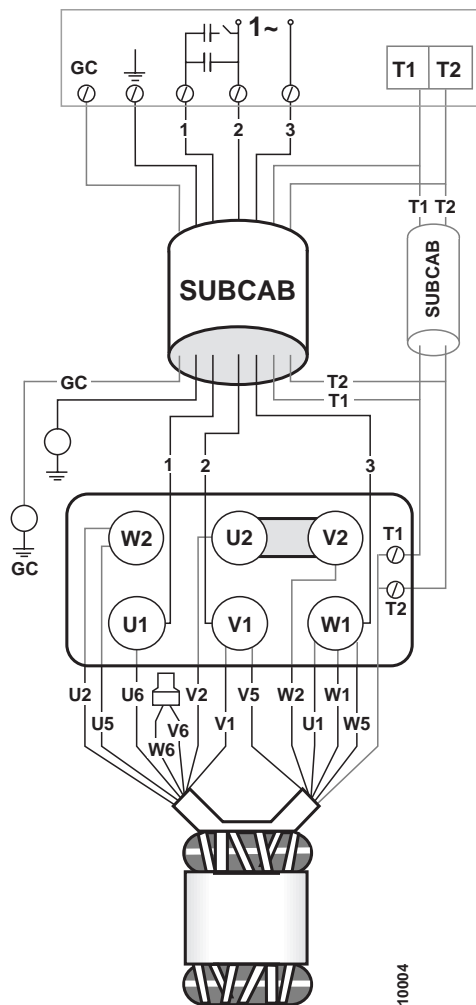

**9-leads
230V**

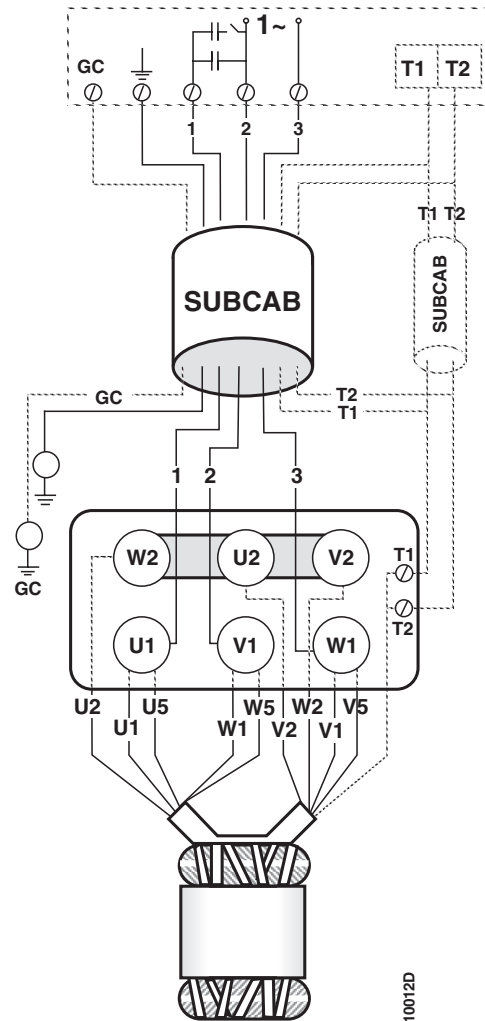

SUBCAB/SUBCAB AWG*:

Mains	Lead	Pump terminal board
L1	Black	U1
L2	Black	W1
L3	Black	V1
L1	Black	W2
L2	Black	V2
L3	Black	U2
Earth (PE)	Yellow/Green	PE
T1	Black	T1
T2	Black	T2

The stator leads are colour-marked as follows:

U1, red
V1, brown
W1, yellow
V2, blue
W2, black
U2, green

Connect the control leads from the motor control circuit to T1 and T2.

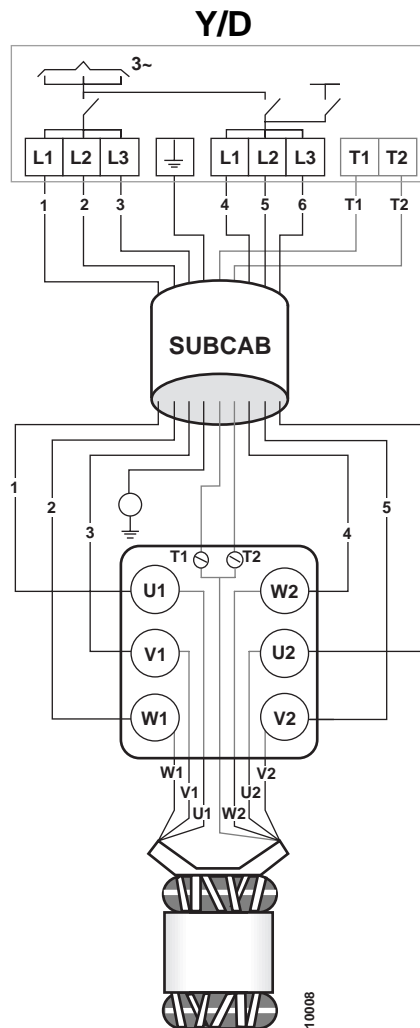

OPERATION

Before starting

Check the oil level in the oil casing.

Remove the fuses or open the circuit breaker and check that the impeller can be rotated by hand.

Check that the monitoring equipment (if any) works.

Check the direction of rotation. The impeller shall rotate clockwise, as viewed from above. When started, the pump will jerk in the opposite direction to the direction in which the impeller rotates. See the figure.

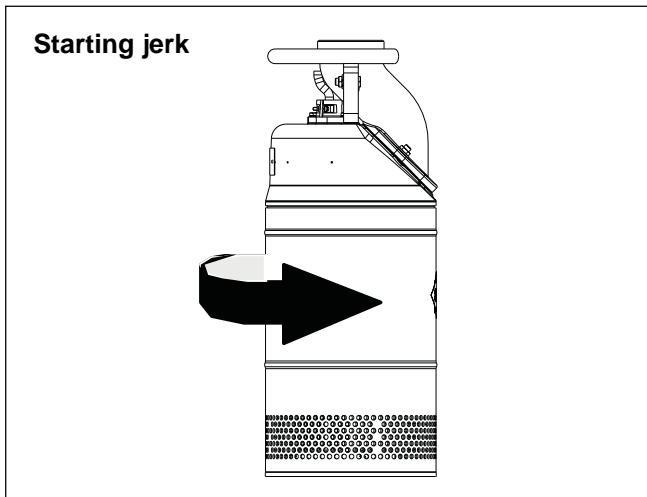

Cleaning

If the pump has been running in very dirty water, let it run for a while in clean water, or flush it through the discharge connection. If clay, cement or other similar dirt is left in the pump it may clog the impeller and seal, preventing the pump from working.

During a longer period out of operation, the pump must be test run every other month to prevent the mechanical seals from sticking together.



WARNING!
Watch out for the starting jerk, which can be powerful.



WARNING!
Always lift the pump by its carrying handle or lifting eyes, never by the motor cable or the hose.

CARE AND MAINTENANCE

Safety precautions



WARNING!
Before starting work on the pump, make sure that the pump is isolated from the power supply and cannot be energized.

Inspection

Regular inspection and preventive maintenance ensure more reliable operation.



The pump should be inspected at least twice a year, more frequently under severe operating conditions. Under normal operating conditions, the pump should have a major overhaul in a service shop once a year. This requires special tools and should be done by an authorized service shop.

When the pump is new or when the seals have been replaced, inspection is recommended after one week of operation.

Service contract

Flygt or its agent offers service agreements in accordance with a preventive maintenance plan. For further information, please contact your Flygt representative.

Recommended inspections:

Inspection of	Action
Visible parts on pump and installation	Replace or fix worn and damaged parts. Make sure that all screws, bolts and nuts are tight.
Pump casing and impeller	Replace worn parts if they impair function.
Condition of the oil	<p>A check of the condition of the oil can show whether there has been an increased leakage. Note! Air/oil mixture can be confused with water/oil mixture. Insert a tube (or hose) into the oil hole. Cover the top end of the tube and take up a little oil from the bottom.</p> <p>Change the oil if it contains too much water, i.e., is heavily emulsified (cream-like), or if the oil housing contains separated water. See “Changing the oil”. Check again one week after changing the oil.</p> <p>If the oil contains too much water again, the fault may be:</p> <ul style="list-style-type: none"> — that an oil screw is not sufficiently tight. — that the O-ring on an oil screw or its sealing surface is damaged. — that the mechanical seal is damaged. Contact a Flygt service shop.
Oil quantity	<p>Table of oil quantities:</p> <p>1.3 litres (1.2 US quarts)</p>
Liquid in the stator casing	<div style="border: 1px solid black; padding: 5px;">  <p>WARNING! If the seal leaks, the oil casing may be under pressure. Hold a rag over the oil casing screw in order to prevent splatter. See “Safety precautions” for additional information.</p> </div>
	<div style="border: 1px solid black; padding: 5px;">  <p>WARNING! If there has been leakage, the stator casing may be under pressure. Hold a rag over the inspection screw to prevent splatter. See “Safety precautions” for additional information.</p> </div>
	<p>Lay the pump on its side.</p> <p>Tilt the pump so that any liquid in the stator casing can run out through the hole.</p> <p>If there is water in the stator casing, the cause may be:</p> <ul style="list-style-type: none"> — that the inspection screw is not sufficiently tight. — that the O-ring on the inspection screw or its sealing surface is damaged. — that an O-ring is damaged. — that the cable entry is leaking. <p>If there is oil in the stator casing, the cause may be:</p> <ul style="list-style-type: none"> — that the inner mechanical seal is damaged. Contact a Flygt service shop.

Recommended inspections:

Inspection of	Action
Cooling system	Rinse and clean if the flow through the system has been partly restricted.
Cable entry	Make sure that the cable clamps are tight. If the cable entry leaks: <ul style="list-style-type: none"> — check that the entry is firmly tightened into its bottom-most position. — cut a piece of the cable off so that the seal sleeve closes around a new position on the cable. — replace the seal sleeve. — check that the seal sleeve and the washers conform to the outside diameter of the cables.
Cables	Replace the cable if the outer jacket is damaged. Make sure that the cable do not have any sharp bends and are not pinched.
Starter equipment	If faulty, contact an electrician.
Rotation direction of pump (requires voltage)	Transpose two phase leads if the impeller does not rotate clockwise as viewed from above. Rotation in the wrong direction reduces the capacity of the pump and the motor may be overloaded. Check the direction of rotation, during non-load every time the pump is reconnected.
Pipes, valves and other peripheral equipment	Repair faults and notify supervisor of any faults or defects.
Insulation resistance in the stator	Contact a Flygt service shop.

Changing the oil

Oil casing

Remove the strainer bottom and outer casing.

Note! Use the special dismantling tool to remove casing. For more information please refer to the impeller change-instructions on the next page.

Unscrew the oil screw.

Turn the pump so that the oil hole faces downwards.

It is easier to drain the oil if another oil screw is also removed.

Fill up with new oil.

A paraffin oil with viscosity close to ISO VG15 is recommended (e.g. Mobil Whiterex 309). The pump is delivered from factory with this type of oil.

In applications where poisonous properties are of less concern, a mineral oil with viscosity up to ISO VG32 can be used.

Always replace the O-rings on the oil screws. Put the screws back and tighten them.

Please see Parts List for the correct tightening torque.

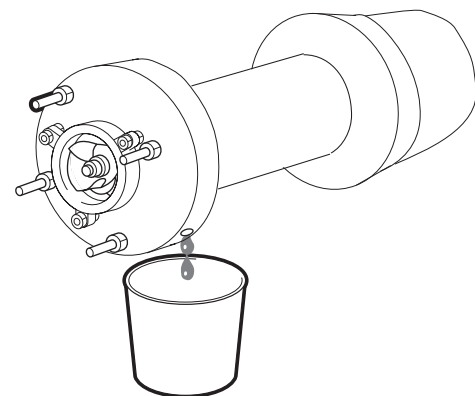
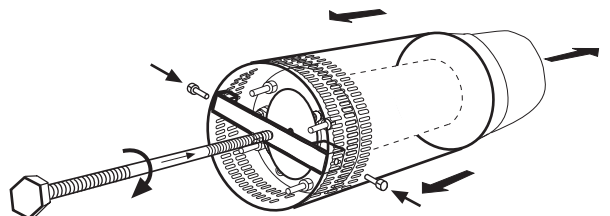
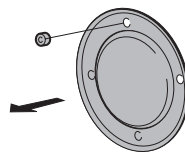

WARNING!
If the seal leaks, the oil casing may be under pressure. Hold a rag over the oil screw to prevent splatter.

Replacing the impeller

When fitting the new wear parts, a clearance must be provided between the impeller and the suction cover of at least 0.2—0.3 mm.

Check after installation that the impeller rotates freely.



WARNING!
Worn impellers often
have very sharp edges.

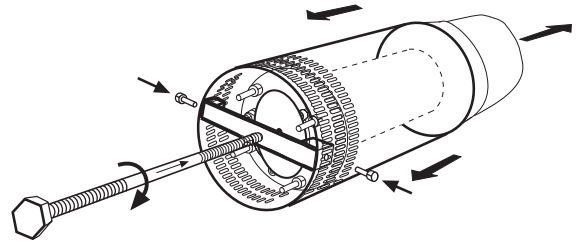
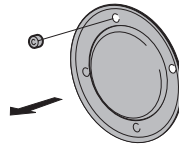

Removing the impeller

Please note!

For easier service we recommend a special dismantling/ assembly tool available from Flygt, p/n 663 62 00, which consists of:

- 1 long centre-bolt
- 1 Cross-bar
- 2 x securing screws
- 1 Pressure plate
- 2 x assembly nuts

Lay the pump on its side.

Remove nuts and pull off the strainer bottom.

Fit the dismantling tool and pressure plate inside the outer casing.

Secure the cross-bar in place with the 2 screws, through suitable strainer holes in the casing.

Insert the long centre-bolt into the cross-bar, making sure that it lands against the pressure plate and turn it to until the outer casing is completely removed. See also upper sketch.

Remove nuts.

Remove the suction cover.

Remove the nuts.

Remove the diffuser.

Remove the impeller nut.

Pull off the impeller.

Do **not** pry off the impeller, since it can easily be damaged. If it is necessary to change the diffuser, the oil has to be drained away.

Then remove the studs and the diffuser.

Installing the impeller

Make sure that the end of the shaft is clean and free of burrs. Polish off any flaws with fine emery cloth.

Check:

- that the diffuser is properly mounted.
- that the key is seated in the keyway on the shaft.
- that an appropriate number of adjusting washers are on the shaft.

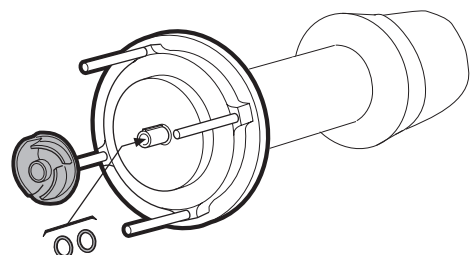
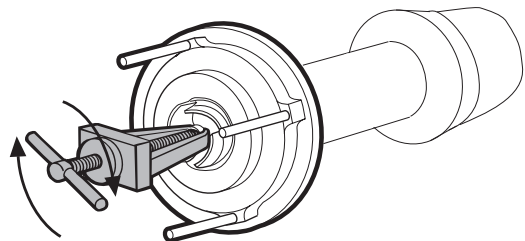
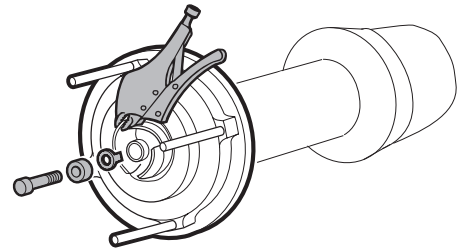
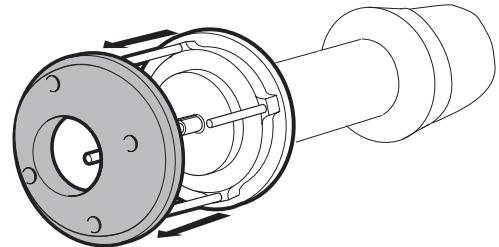
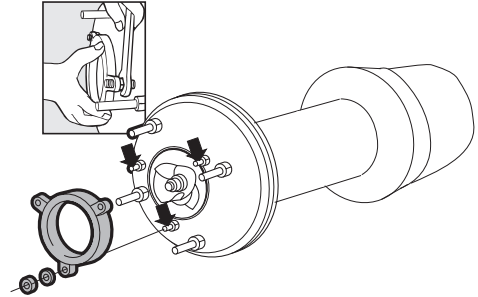

Installing the impeller . . . continued

Fit the adjusting studs properly.

Grease end of shaft.

Press the impeller onto the shaft with the impeller nut.

Tighten the impeller nut.

Tightening torque: 30 Nm

The clearance between the impeller and the oil casing bottom should be 0.2—0.3 mm when the impeller is tightened. The clearance can be adjusted with the adjusting washers.

Check that the impeller can easily be rotated by hand.

Install the lower diffuser.

Press the suction cover against the impeller.

The clearance between the impeller and the suction cover shall be as little as possible.

Adjust the suction cover with the inner nuts so that there is a clearance between the suction cover and impeller.

Place the nuts on the adjusting studs in a fixed position.

Tighten the nuts evenly all around.

Check that the impeller can easily be rotated by hand.

Install the outer casing, making sure that it is axially position against the pump-top by using 2 nuts and the assembly tool (cross-bar) as shown in bottom sketch. Remove the assembly tool and fit the strainer bottom.

In order for the pump to perform at maximum capacity, the impeller must be adjusted regularly.

It is particularly important that the clearance between the suction cover and the impeller is kept to a minimum.

More extensive repairs require special tools and should be carried out by an authorized service technician.

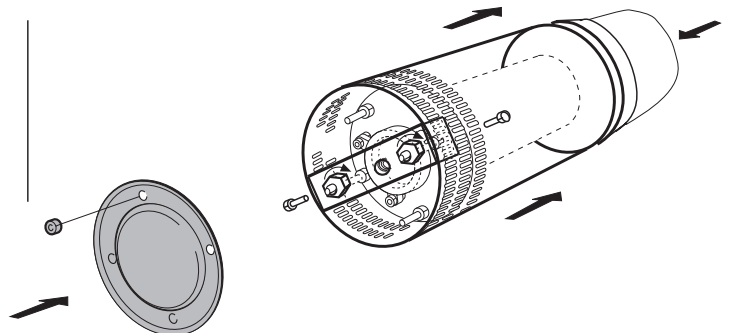
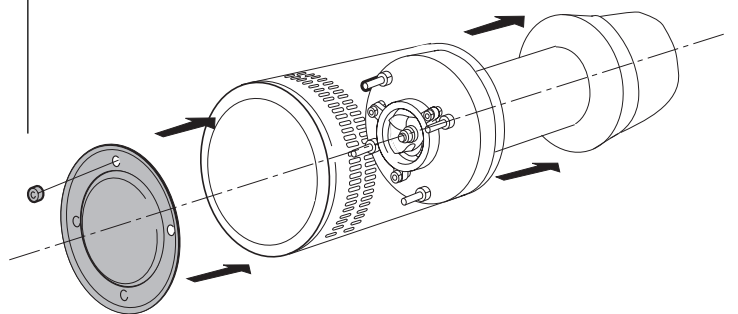
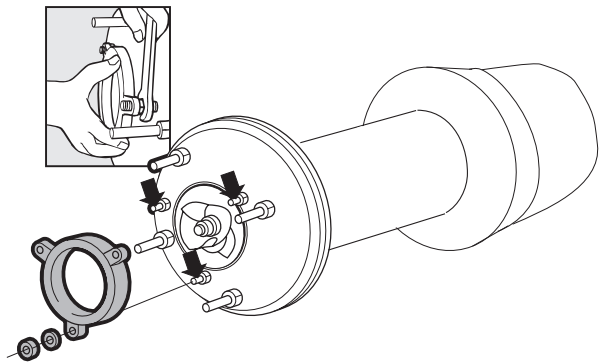
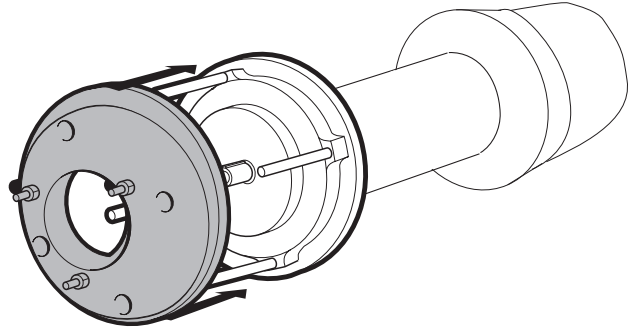
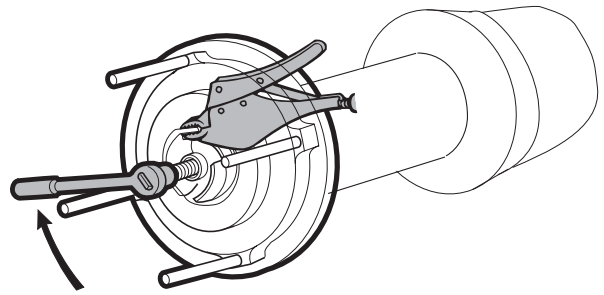

Replacing the mechanical seal

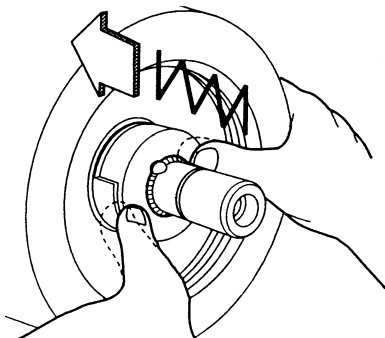
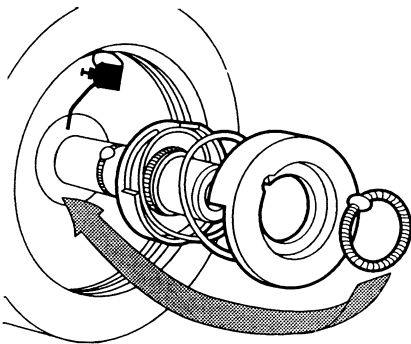
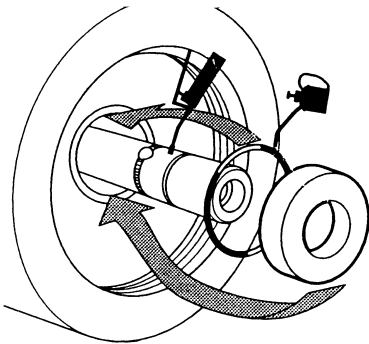
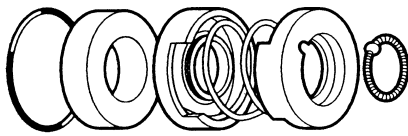
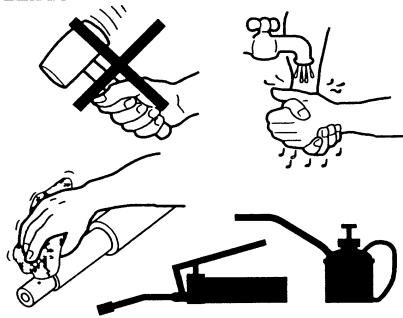

MAIN PARTS

Spare parts for the 2102.220 pump can be found in the spare parts list delivered with each pump.
Please contact your local dealer for further details regarding spare parts etc.

Item	Denomination
1.	Discharge connection
2.	Cable entry
3.	Junction box / cover
4.	Lifting handle
5.	Support bearing
6.	Pump cooling jacket
7.	Main bearing
8.	Inner mechanical seal
9.	Outer mechanical seal
10.	Impeller
11.	Diffuser
12.	Strainer / Outer casing
13.	Shaft unit
14.	Motor
15.	Suction cover

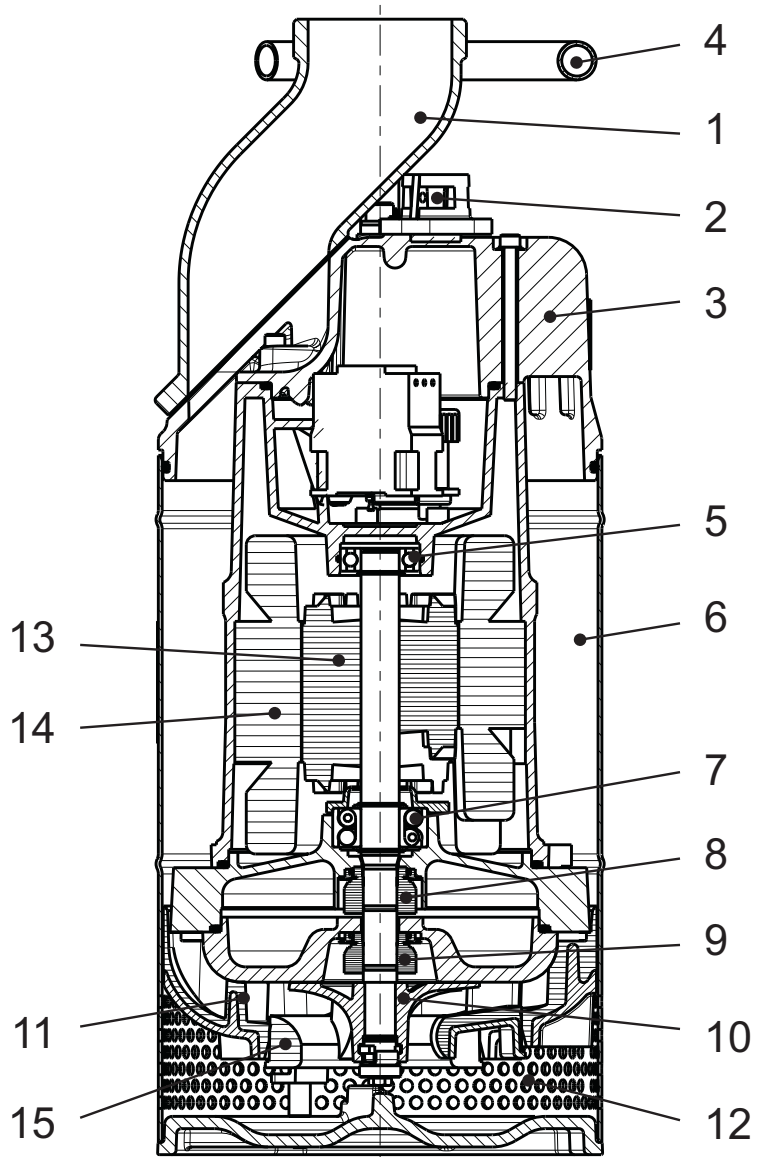

SERVICE LOG

Most recent service date	Pump No.	Hours of operation	Remarks	Sign.



www.flygt.com