



Installation, care and maintenance

2084.330



GUARANTEE

Flygt undertakes to remedy faults in products sold by Flygt provided:

- that the fault is due to defects in design, materials or workmanship;
- that the fault is reported to Flygt or Flygt's representative during the guarantee period;
- that the product is used only under conditions described in the care and maintenance instructions and in applications for which it is intended;
- that the monitoring equipment incorporated in the product is correctly connected;
- that all service and repair work is done by a workshop authorized by Flygt;
- that genuine Flygt parts are used.

Hence, the guarantee does not cover faults caused by deficient maintenance, improper installation, incorrectly executed repair work or normal wear and tear.

Flygt assumes no liability for either bodily injuries, material damages or economic losses beyond what is stated above.

Flygt guarantees that a spare parts stock will be kept for 10 years after the manufacture of this product has been discontinued.

The manufacturer reserves the right to alter performance, specification or design without notice.

DATA PLATE INTERPRETATION

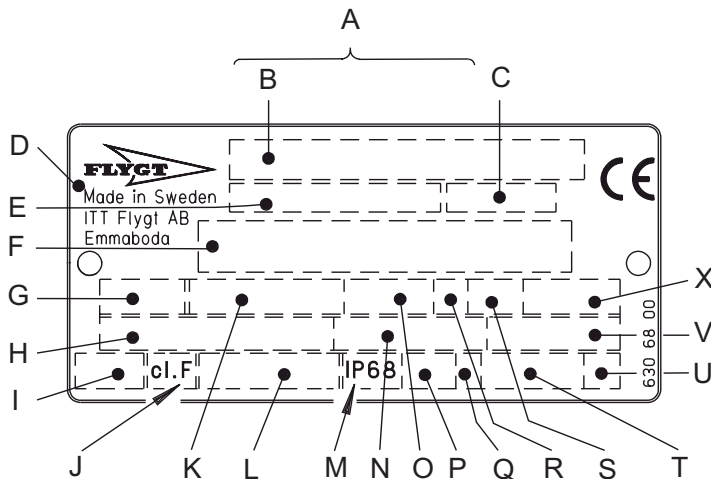

- A Serial number
- B Product code + Number
- C Curve code / Propeller code
- D Country of origin
- E Product number
- F Additional information
- G Phase; Type of current; Frequency
- H Rated voltage
- I Thermal protection
- J Thermal class
- K Rated shaft power
- L International standard
- M Degree of protection
- N Rated current
- O Rated speed
- P Max. submergence
- Q Direction of rotation: L=left, R=right
- R Duty class
- S Duty factor
- T Product weight
- U Locked rotor code letter
- V Power factor
- X Max. ambient temperature

CONTENTS

Product description _____	3	Operation _____	12
Applications _____	3	Care and maintenance _____	13
Dimensions and weights _____	3	Safety precautions _____	13
Motor data _____	3	Inspection _____	13
Design _____	4	Changing the oil _____	16
Technical data _____	5	Removing the impeller _____	16
Transportation and storage _____	5	Fault tracing (Troubleshooting) _____	18
Installation _____	6	Accessories and tools _____	21
Safety precautions _____	6	Exploded view _____	22
Pump installation _____	6		
Electrical connections _____	7		

PRODUCT DESCRIPTION

Applications

2084.330 is intended to be used for pumping of water which may contain abrasive particles.

Liquid temperature: max. 40°C (105°F).

Liquid density: max. 1100 kg/m³ (9.2 lb per US gal.)

The pumped liquid may contain particles up to a size which corresponds to the openings in the strainer.

The pH of the pumped liquid: 5—8.

Depth of immersion: max. 20 m (66 ft).



WARNING
The pump shall not be used in explosive or flammable environments or with flammable liquids.

For other applications, contact your nearest Flygt representative for information.

Dimensions and weights

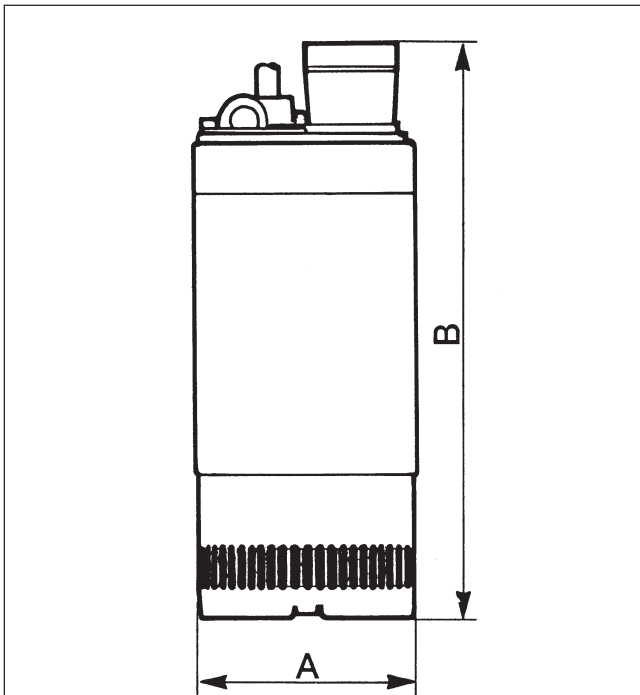

All dimensions are in mm (in).

A = 244 (9.6)

B = LT: 740 (29.1)

MT: 840 (33.1)

HT: 1080 (42.5)

All weights are in kg (lb).

LT: 55 (121)

MT: 75 (165)

HT: 110 (243)

Motor data

Rated output: 3.7 kW, 3 ~ 50 Hz 2830 rpm

Voltage V	Rated current A	Starting current A
200Δ	14.0	102
220Δ	13.0	80
380Y	7.3	46
415Δ	6.7	41
500Δ	5.7	32
550Δ	5.0	32

Rated output: 7.5 kW, 3 ~ 50 Hz 2870 rpm

Voltage V	Rated current A	Starting current A
200Δ	27.0	210
220Δ	14.0	183
380Y	14.0	105
415Δ	13.0	93
500Δ	11.0	76
550Δ	9.7	85

Rated output: 14.0 kW, 3 ~ 50 Hz 2870 rpm

Voltage V	Rated current A	Starting current A
200Δ	50.0	495
220Δ	27.0	400
380Y	27.0	229
415Δ	24.0	201
500Δ	20.0	161
550Δ	18.0	160

Rated output: 4.7 kW, 3 ~ 60 Hz 3400 rpm

Voltage V	Rated current A	Starting current A
200Δ	18.0	80.0
220Δ	17.0	88.0
440Y	8.4	44.0
460Y	8.0	46.0
500Δ	7.7	32.0

Rated output: 9.0 kW, 3 ~ 60 Hz 3440 rpm

Voltage V	Rated current A	Starting current A
200Δ	35.0	190.0
220Δ	31.0	209.0
440Y	16.0	114.0
460Y	15.0	119.0
575Δ	12.0	85.0

Rated output: 16.0 kW, 3 ~ 60 Hz 3480 rpm

Voltage V	Rated current A	Starting current A
200Δ	58.0	417.0
220Δ	53.0	459.0
440Y	27.0	225.0
460Δ	25.0	235.0
575Δ	20.0	141.0

Design

2084 is a submersible, electric motordriven pump.

Impellers

Three-vane impellers of cast iron or stainless steel.

Shaft seals

The pump has two mechanical seals.

Materials:

Inner seal: tungsten carbide — tungsten carbide.

Outer seal:

tungsten carbide — tungsten carbide.

Shaft

The shaft is delivered with the rotor as an integral part.

Shaft material: stainless steel.

Bearings

The pump bearings are designed for at least 8 000 hours of operation.

The lower bearing consists of: LT and MT version:

One double-row angular contact ball bearing.

HT version: Two single-row angular contact ball bearing.

The upper bearing consists of: a single-row ball bearing.

Oil casing

The oil lubricates and cools the seals and acts as a buffer between the pump casing and the electric motor.

Pressure build-up within the oil casing is reduced by means of a built-in air volume.

Motor

Squirrel-cage 3-phase induction motor for 50 Hz or 60 Hz.

The motor is started by means of, direct on-line start transformer start or star-delta start.

The stator is insulated in accordance with class F (155°C, 310°F). The motor is designed to supply its rated output at $\pm 5\%$ variation of the rated voltage. Without overheating the motor, $\pm 10\%$ variation of the rated voltage can be accepted provided that the motor does not run continuously at full load. The motor is designed to operate with a voltage imbalance of up to 2 % between the phases.

Monitoring equipment

The stator incorporates two thermal switches connected in series.

The thermal protectors open at 125°C (260°F).

See also "Electrical connections" and separate instructions for starter equipment.

Cooling

The stator is cooled by the pumped liquid passing through the space between the stator casing and the outer casing.



NOTE!

Make sure that the monitoring equipment incorporated in the product is correctly connected.

Technical data

The pump curves show:

- input power at various operating points.
- flow rate versus total head.

LT = low-head version

M = medium-head version

HT = high-head version

For further information, see "Parts list".

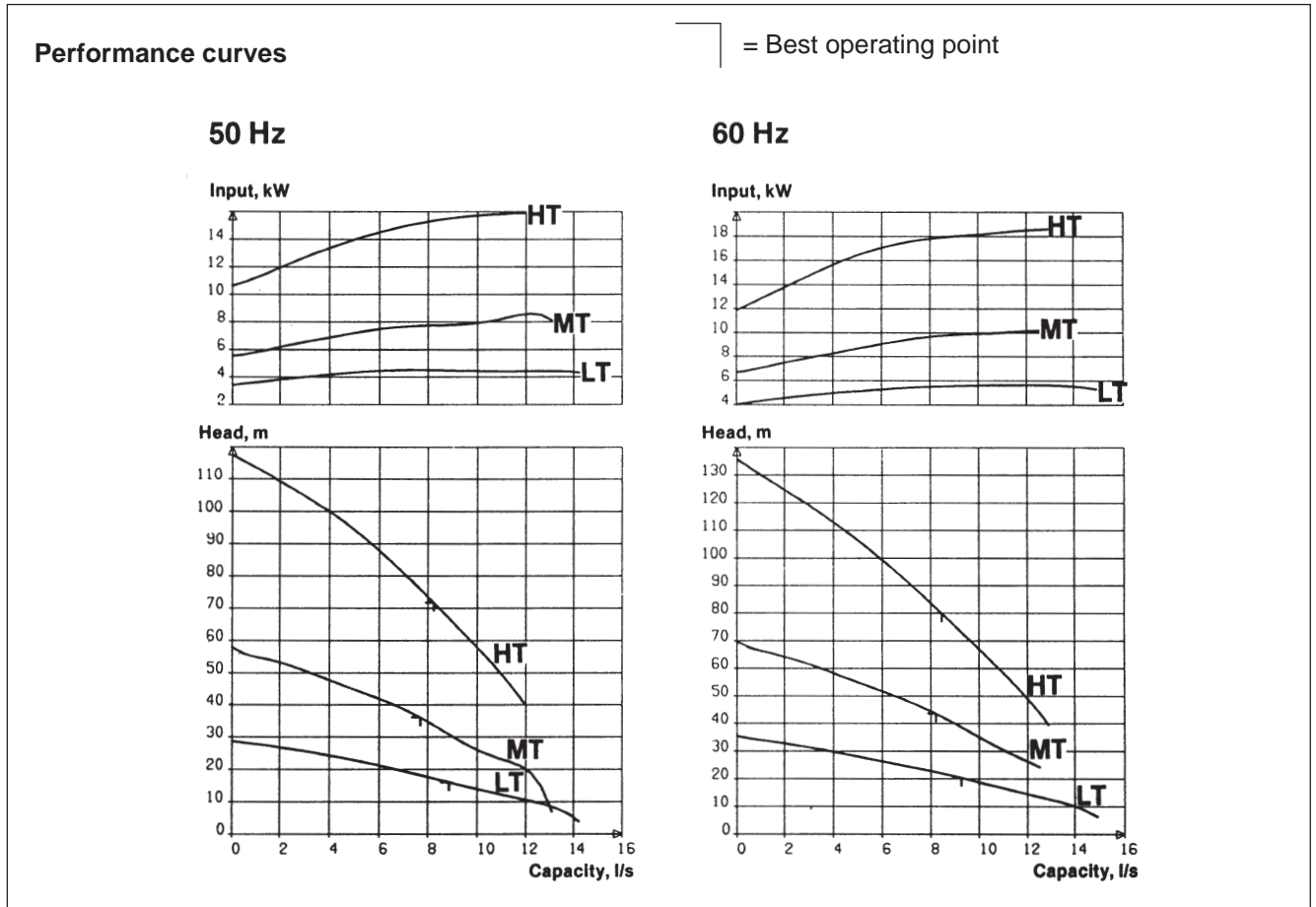

TRANSPORTATION AND STORAGE

The pump may be transported and stored in a vertical or horizontal position. Make sure that it cannot roll or fall over.



WARNING!

Always lift the pump by its carrying handle or lifting eyes, never by the motor cable or the hose.

The pump is frostproof as long as it is operating or is immersed in the liquid. If the pump is taken up when the temperature is below freezing, the impeller may freeze. The pump shall be operated for a short period after being taken up in order to expel all remaining water.

A frozen impeller can be thawed by allowing the pump to stand immersed in the liquid for a short period before it is started. Never use an open flame to thaw the pump.

For longer periods of storage, the pump must be protected against moisture and heat. The impeller should be rotated by hand occasionally (for example every other month) to prevent the seals from sticking together. If the pump is stored for more than 6 months, this rotation is mandatory.

After a long period of storage, the pump should be inspected before it is put into operation. Pay special attention to the seals and the cable entry.

Follow the instructions under the heading "Before starting".

INSTALLATION

Safety precautions

In order to minimize the risk of accidents in connection with the service and installation work, the following rules should be followed:

1. Make sure the lifting equipment is in good condition.
2. Be aware of the risk of electrical accidents.
3. Use a safety helmet, safety goggles and protective shoes.
4. Do not ignore the risk of drowning.
5. A first-aid kit must be handy.

Follow all other health and safety rules and local codes and ordinances.



At certain installations and operation points on the pump curve the noise level 70 dB, or for the actual pump specified noise level, can be exceeded.

Pump installation

Run the cables so that they do not have any sharp bends and are not pinched.

Connect the discharge connection and motor cable. See “Electrical connections”.

Lower the pump into the sump.

Place the pump on a base which will prevent it from sinking into a soft sump bottom. Alternatively, the pump can be suspended by its handle just above the sump bottom.

For tandem connection of pumps, see “Accessories and tools”.

Consult your nearest Flygt representative regarding:

- choice of peripheral equipment.
- other problems in connection with installation.

ELECTRICAL CONNECTIONS

All electrical work shall be carried out under the supervision of an authorized electrician.



WARNING!
All electrical equipment must be earthed. This applies to both pump equipment and any monitoring equipment. Failure to heed this warning may cause a lethal accident. Make sure that the earth lead is correctly connected by testing it.

Local codes and regulations shall be complied with.

Check that the mains voltage and frequency agree with the specifications on the pump data plate.

The motor can only be connected for different voltages as shown on the data plate.

Under no circumstances may the starter equipment be installed in the pump pit.

Install the motor cable and the control cable as illustrated in the figure.

To avoid leakage into the pump, check:

- that the cable entry seal sleeve and washers conform to the outside diameter of the cable. See the parts list.
- that the outer jacket on the cable is not damaged. When refitting a cable which has been used before, **always** cut off a short piece of the cable so that the cable entry seal sleeve does not close around the cable at the same point again.



NOTE!
For safety reasons, the earth lead should be approx. 70 mm (2¾") longer than the phase leads. If the motor cable is jerked loose by mistake, the earth lead should be the last lead to come loose from its terminal. This applies to both ends of the cable.

Check on the data plate which connection, Y or Δ, is valid for the voltage supply. Then, depending on voltage, arrange the connection on the terminal board in accordance with Y or Δ.

Connect the motor cable to the terminal board connections U1, V1, W1 and earth.

If star-delta start is used, both motor cables are connected as shown in the figure. Links are not used with star-delta start.

Connect the leads from the motor control circuit to T1 and T2.



NOTE!
Make sure that the monitoring equipment incorporated in the product is correctly connected.

Make sure that the pump is correctly earthed (grounded).

Install the cover (75).

Tighten the screws (4) so that the cable entry unit bottoms out.

Connect the motor cable and the control cable to the starter equipment. Check the direction of rotation, see "Before starting".

If the direction of rotation is wrong, transpose two of the phase leads.

For 1-phase pumps going in wrong direction, please contact your nearest Flygt representative.

Remember that the starting surge with the direct-on line start can be up to six times higher than the rated current. Make sure that the fuses or circuit breakers are of the proper amperage.

The table on page 3 gives rated current and starting current. Fuse amperage and cable shall be selected in accordance with local rules and regulations. Note that with long cables, the voltage drop in the cable must be taken into consideration, since the motor's rated voltage is the voltage that is measured at the terminal board in the pump.

Electrical connections

SUBCAB 4G/SUBCAB AWG*:

Mains	Lead	Pump terminal board
L1	Brown (Red*)	U1
L2	Blue (White*)	W1
L3	Black (Black*)	V1
Earth	Yellow/green	⏚
Groundcheck	Yellow*	GC
T1	Black/orange*	T1
T2	Black/blue*	T2

The stator leads are connected to the terminal board as follows:

Stator lead	Connection on terminal board
U1, red	U1
V1, brown	V1
W1, yellow	W1
V2, blue	V2
W2, black	W2
U2, green	U2

Connect the control leads from the motor control circuit to T1 and T2.

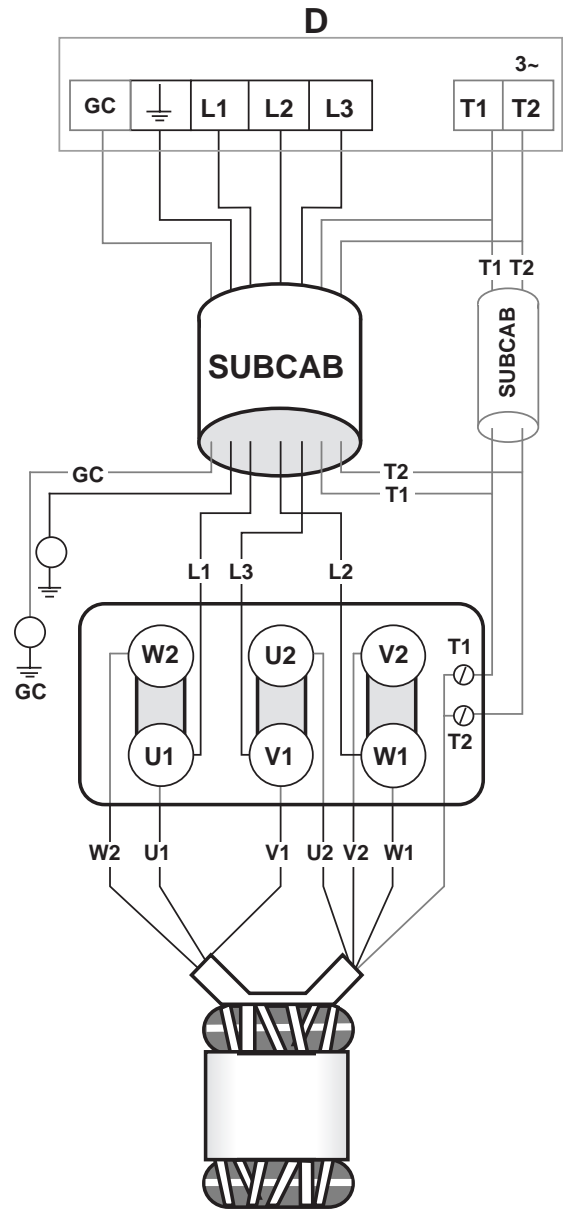
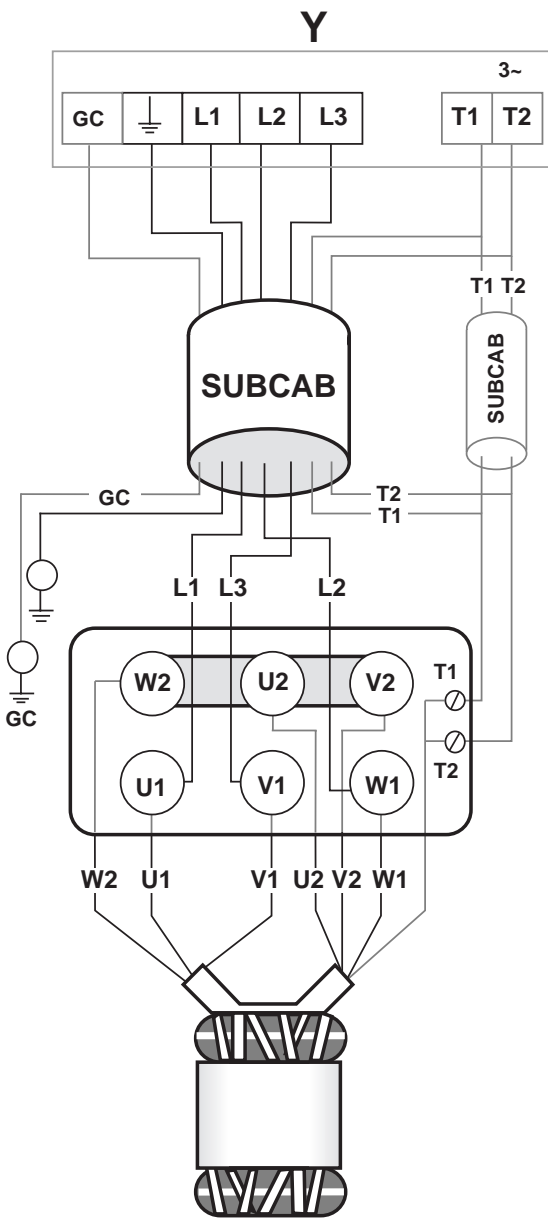

Electrical connections

SUBCAB 7G

Mains	Lead	Pump terminal board
L1	Black 1	U1
L2	Black 2	W1
L3	Black 3	V1
L1	Black 4	W2
L2	Black 5	V2
L3	Black 6	U2
Earth	Yellow/green	⏚
T1	Black T1	T1
T2	Black T2	T2

Connect the control leads from the motor control circuit to T1 and T2.

The stator leads are colour-marked as follows:

- U1 (S1) - red
- V1 (S2) - brown
- W1 (S3) - yellow
- U2 (S6) - green
- V2 (S4) - blue
- W2 (S5) - black

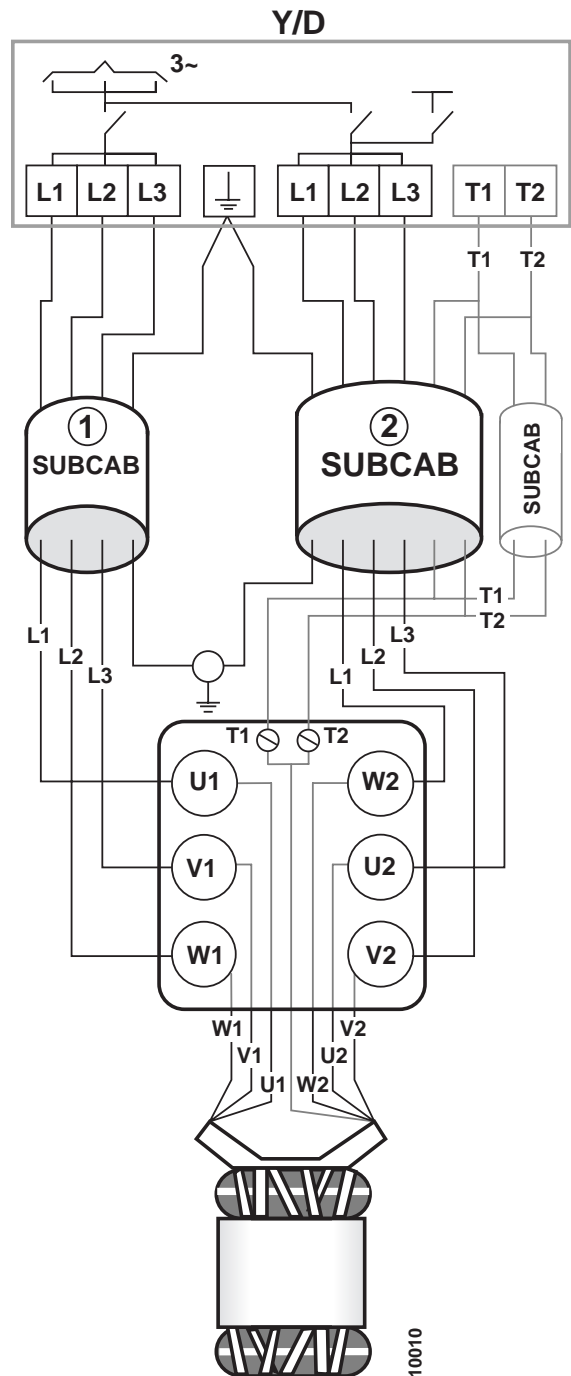
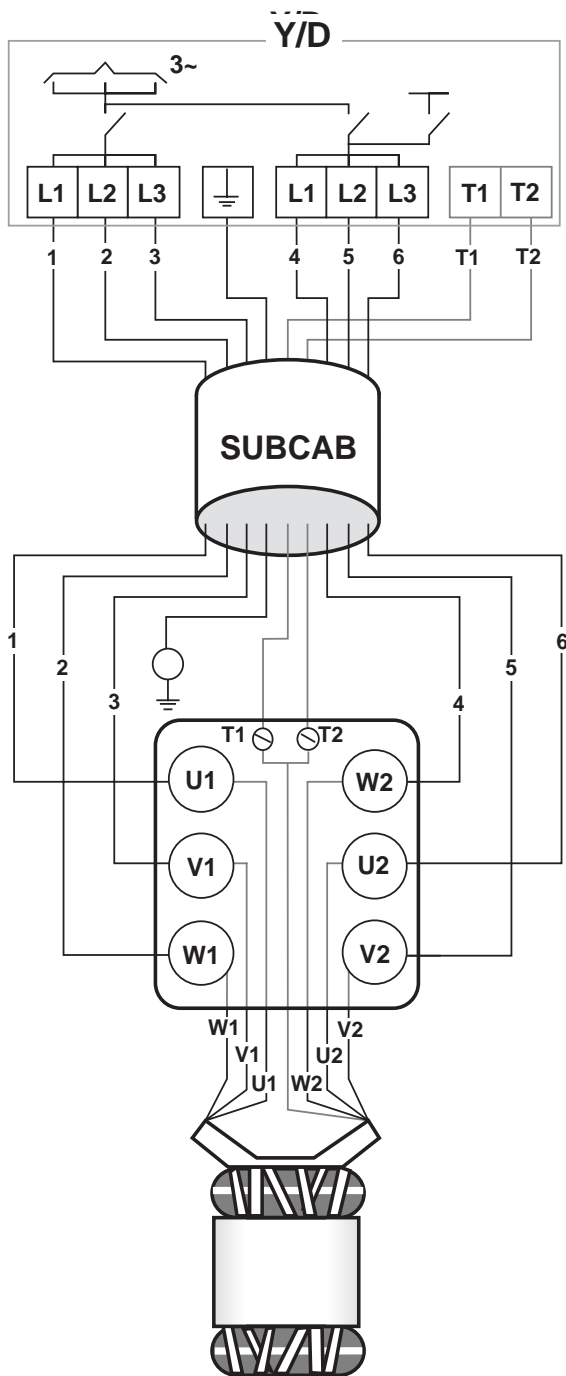

10010

Electrical connections, 9-starter leads, 60 Hz only

SUBCAB 4G/SUBCAB AWG*:

Mains	Lead	Pump terminal board
L1	Brown (Red*)	U1
L2	Blue (White*)	W1
L3	Black (Black*)	V1
Earth	Yellow/green	⏚
Groundcheck	Yellow*	GC
T1	Black/orange*	T1
T2	Black/blue*	T2

The stator leads are colour-marked as follows:

- U1 (S1) - red
- V1 (S2) - brown
- W1 (S3) - yellow
- U2 (S4) - green
- V2 (S5) - blue
- W2 (S6) - black
- U5 (S7) - red
- V5 (S8) - brown
- W5 (S9) - yellow

Connect the control leads from the motor control circuit to T1 and T2.

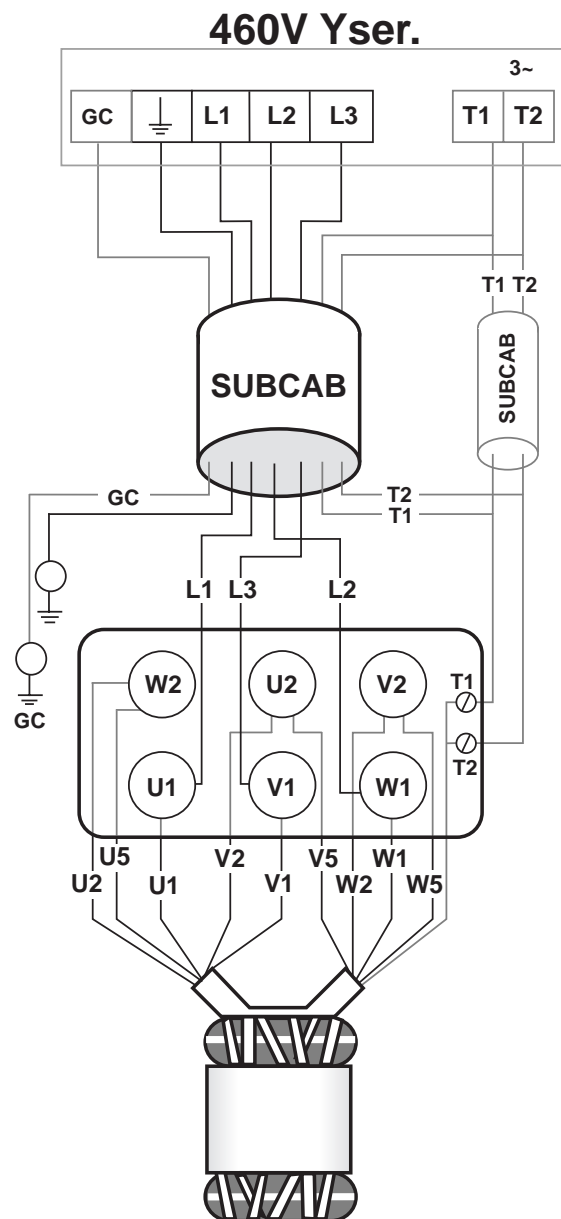
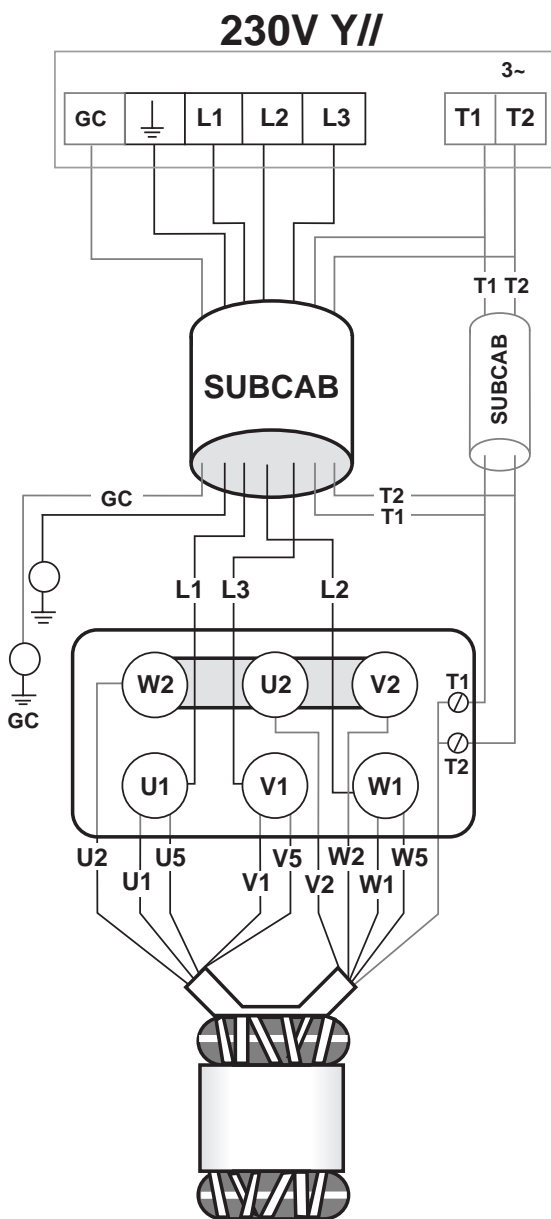

Electrical connections, 12-stator leads, 60 Hz only

SUBCAB/SUBCAB AWG*:

Mains	Lead	Pump terminal board
L1	Brown (Red*)	U1
L2	Blue (White*)	W1
L3	Black (Black*)	V1
Earth (PE)	Yellow/Green	PE
Groundcheck	Yellow*	GC
T1	Black (Orange*)	T1
T2	Black (Blue*)	T2

The stator leads are colour-marked as follows:

- U1, red
- V1, brown
- W1, yellow
- U2, green
- V2, blue
- W2, black
- U5, red
- V5, brown
- W5, yellow
- U6, green
- V6, blue
- W6, black

Connect the control leads from the motor control circuit to T1 and T2.

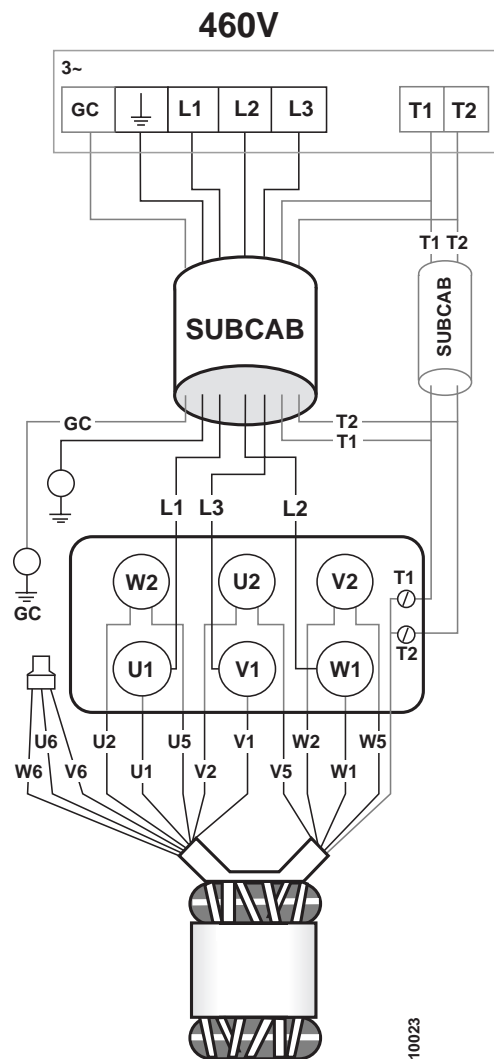
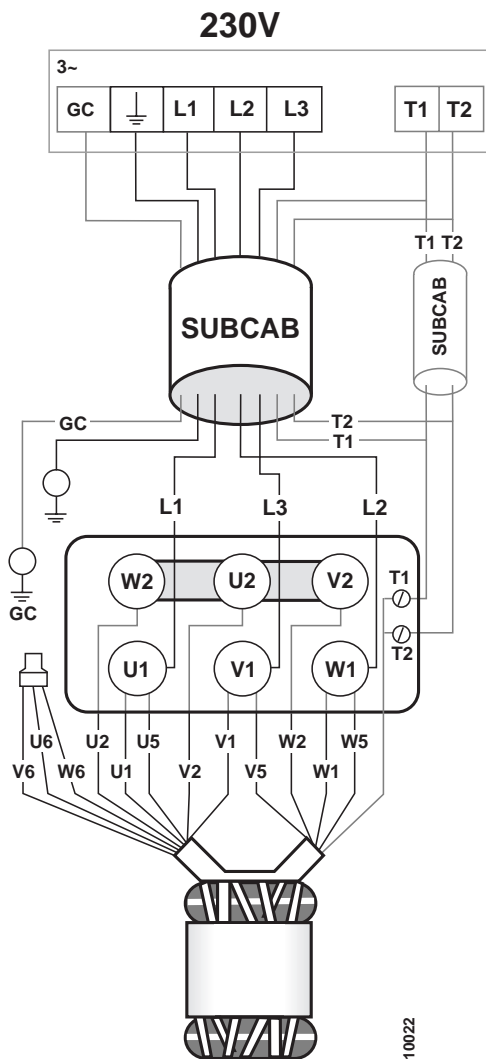

OPERATION

Before starting

Check the oil level in the oil casing.

Remove the fuses or open the circuit breaker and check that the impeller can be rotated by hand.

Check that the monitoring equipment (if any) works.

Check the direction of rotation. See the figure. The impeller shall rotate clockwise, as viewed from above.

When started, the pump will jerk in the opposite direction to the direction in which the impeller rotates.



WARNING!
Watch out for the starting jerk,
which can be powerful.

Starting jerk

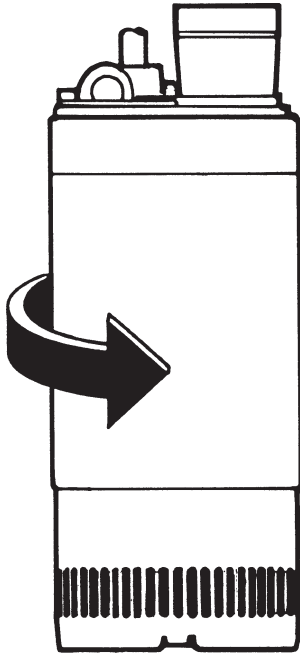

In order to avoid sedimentation when the pumped liquid contains solid particles, the velocity of the medium in the discharge line should be:

Mixture	Min. velocity in discharge line
1. Water + coarse gravel	4 m/s (13.2 ft/s)
2. Water + gravel	3.5 m/s (11.5 ft/s)
3. Water + sand	
Sand particles <0.1 mm (0.004 in)	1.5 m/s (5.0 ft/s)
Sand particles <0.6 mm (0.024 in)	2.5 m/s (8.2 ft/s)

Choose dimension of the discharge line to give the pumped liquid at least this velocity.

The pump can be provided with level regulation in order to prevent unnecessary wear on the hydraulic components.

Cleaning

If the pump has been running in very dirty water, let it run for a while in clean water, or flush it through the discharge connection. If clay, cement or other similar dirt is left in the pump it may clog the impeller and seal preventing the pump from working.

During a longer period out of operation, the pump must be test run every other month to prevent the mechanical seals from sticking together.

CARE AND MAINTENANCE

The figures in parentheses are item numbers and refer to the exploded view.



Before starting work on the pump, make sure that the pump is isolated from the power supply and cannot be energized. This applies til the control circuit as well.

Safety precautions

The following points are important in connection with work on the pump:

- make sure that the pump has been thoroughly cleaned.
- observe good personal hygiene.
- beware the risk of infection.
- follow local safety regulations.

Inspection

Regular inspection and preventive maintenance ensure more reliable operation.

The pump should be inspected at least twice a year, more frequently under severe operating conditions.

Under normal operating conditions, the pump should have a major overhaul in a service shop once a year.



This requires special tools and should be done by an authorized service shop.

When the pump is new or when the seals have been replaced, inspection is recommended after one week of operation.

Service contract

Flygt or its agent offers service agreements in accordance with a preventive maintenance plan. For further information, please contact your Flygt representative.

Recommended inspections:

Inspection of	Action
Visible parts on pump and installation	<p>Replace or fix worn and damaged parts.</p> <p>Make sure that all screws, bolts and nuts are tight.</p> <p>Check condition of carrying handle/lifting eyes, chains and wire ropes.</p>
Pump casing and impeller	<p>Replace worn parts if they impair function.</p> <p>Wear on the impeller and the parts around it necessitates fine adjustment of the impeller or replacement of worn parts. See “Replacing the impeller” and “Replacing the diffuser”.</p>
Oil quantity	<div data-bbox="453 479 1441 645" style="border: 1px solid black; padding: 5px;">  <p>WARNING! If the seal leaks, the oil casing may be under pressure. Hold a rag over the oil casing screw in order to prevent splatter. See “Safety precautions” for additional information.</p> </div> <p>Check that the oil reaches up to the oil hole.</p> <p>Add oil as needed. See “Changing the oil”.</p>
Condition of the oil	<p>A check of the condition of the oil can show whether there has been an increased leakage. Note! Air/oil mixture can be confused with water/oil mixture.</p> <p>Insert a tube (or hose) into the oil hole. Cover the top end of the tube and take up a little oil from the bottom.</p> <p>Change the oil if it contains too much water, i.e., is heavily emulsified (cream-like), or if the the oil casing contains separated water. See “Changing the oil”. Check again one week after changing the oil.</p> <p>If the oil contains too much water again, the fault may be:</p> <ul style="list-style-type: none"> — that an oil screw (19) is not sufficiently tight. — that an O-ring (40, 42, 45, 46) or its sealing surface is damaged. — that the lower mechanical seal (80) is damaged. Contact a Flygt service shop.
Liquid in the stator casing	<div data-bbox="453 1196 1441 1361" style="border: 1px solid black; padding: 5px;">  <p>WARNING! If there has been leakage, the stator casing may be under pressure. Hold a rag over the inspection screw to prevent splatter. See “Safety precautions” for additional information.</p> </div> <p>Lay the pump on its side.</p> <p>Remove the inspection screw (19) and the O-ring (40).</p> <p>Turn the pump so the inspection hole faces downward.</p> <p>Tilt the pump so that any liquid in the stator casing can run out through the hole.</p> <p>If there is water in the stator casing, the cause may be:</p> <ul style="list-style-type: none"> — that the inspection screw (19) is not sufficiently tight. — that an O-ring of the inspection screw or its sealing surface is damaged. — that an O-ring (40, 42, 45, 46) is damaged. — that the cable entry is leaking. <p>If there is oil in the stator casing, the cause may be:</p> <ul style="list-style-type: none"> — that the inner mechanical seal (90) is damaged. Contact a Flygt service shop.

Recommended inspections:

Inspection of	Action
Cable entry	Make sure that the cable clamps are tight. If the cable entry leaks: <ul style="list-style-type: none">— check that the entry is firmly tightened into its bottom-most position.— cut a piece of the cable off so that the seal sleeve (55) closes around a new position on the cable.— replace the seal sleeve (55).— check that the seal sleeve (55) and the washers (29) conform to the outside diameter of the cables.
Cables	Replace the cable if the outer jacket is damaged. Make sure that the cable do not have any sharp bends and are not pinched.
Level sensors or other level equipment	Check function. Clean, adjust, replace or repair damaged level sensing equipment. Follow the instructions for the level sensing equipment in question.
Starter equipment	If faulty, contact an electrician.
Rotation direction of pump (requires voltage)	Transpose two phase leads if the impeller does not rotate clockwise as viewed from above. Rotation in the wrong direction reduces the capacity of the pump and the motor may be overloaded. Check the direction of rotation, during non-load every time the pump is reconnected.
Pipes, valves and other peripheral equipment	Repair faults and notify supervisor of any faults or defects.
Insulation resistance in the stator	Contact a Flygt Serviceshop.

Changing the oil



WARNING. If the seal leaks, the oil casing may be under pressure. Hold a rag over the oil plug to prevent splatter.

Lay the pump on its side on a bench or over two supports.

Unscrew the oil casing screw (19).

Turn the pump so that the oil hole faces downwards.

It is easier to drain the oil if the other oil hole screw is also removed.

Fill up with 0.8 litres (0.84 US quarts) of new oil. Always replace the O-rings of the oil hole screws. Put the screws back and tighten them.

A paraffin oil with viscosity close to ISO VG15 is recommended (e.g. Mobil Whiterex 309). The pump is delivered from factory with this type of oil.

In applications where poisonous properties are of less concern, a mineral oil with viscosity up to ISO VG32 can be used.

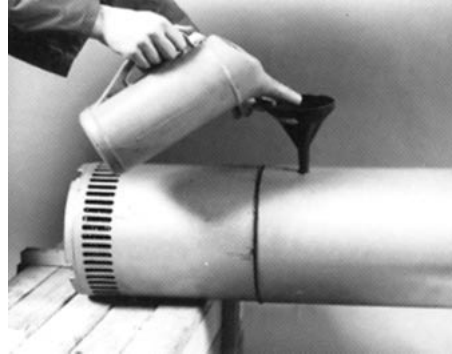
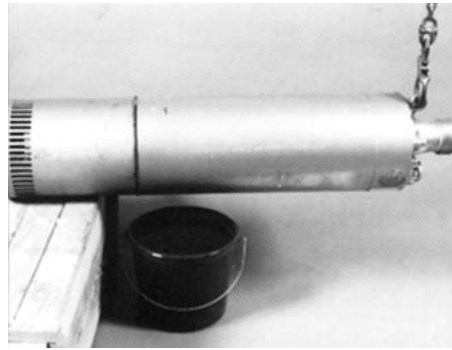

Removing the impeller



WARNING!
Worn impellers often have very sharp edges.

Lay the pump on its side.

Remove nuts (25), washers (31) and screw (6) and press off the strainer (98) with a long M12 screw.

Remove further nuts (25), washers (31) and spacing sleeves (99). Pull off diffuser ring (62).

Remove impeller screw (20).

Pull off the impeller.

Use a puller or pry off carefully with two strong screwdrivers or bars.

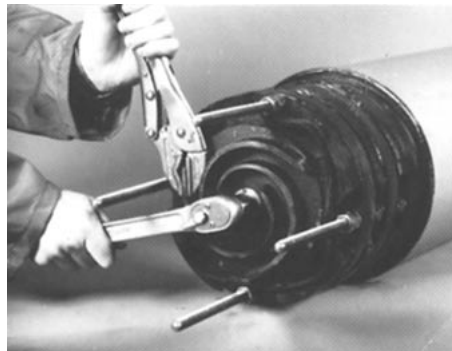
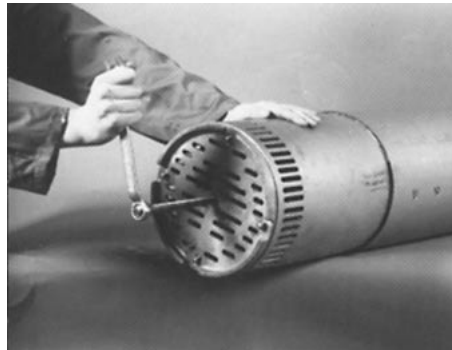

Installing the impeller

Make sure that the end of the shaft is clean and free of burrs. Polish off any flaws with fine emery cloth. Check that the key (1) is seated in the keyway on the shaft.

Press the impeller onto the shaft.

1-stage LT

Tighten the washers (33, 34) with the impeller screw (20).

Tightening torque 30 Nm (22 ft.-lbs).

Press the diffuser ring (62) against the impeller.

Screw the adjusting nuts (25) so that they lie flush against the diffuser ring (62). Back off all adjusting nuts another half-turn (anti-clockwise).

2-stage MT

Press impeller (59) no 1 onto the shaft shoulder. Install sleeve (94), key (1) no 2, diffuser ring (60) with nuts (25) and spring washers (31).

Press impeller (59) no 2 onto the shaft.

Tighten the washers (33, 34) with the impeller screw (20).

Tightening torque 30 Nm (22 ft.-lbs).

Press the diffuser ring (62) against the impeller no 2.

Adjust and secure the diffuser rings (60, 62) as described for the 1-stage pump.

4-stage HT

Install and adjust as described above further two impellers (59) and two intermediary diffuser rings (61).

Note the difference between diffuser rings 60 and 61.

Generally

In order for the pump to perform at maximum capacity, the diffuser rings must be adjusted regularly.

After concluded adjustments, check

- that all nuts (25) are tightened,
- that the shaft can easily be rotated by hand.

Install the protection sleeves (99) on the studs (21). Grease the outer surface of the diffuser rings a little. (Preferably silicon grease).

Pass the strainer unit (98) over the diffuser rings and secure it with spring washers (31) and nuts (25).

Install the screw (6) in the M12 hole in order to protect the press off thread.

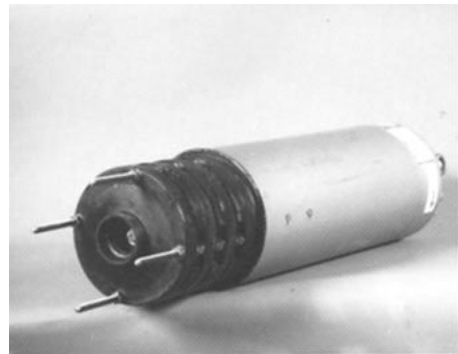
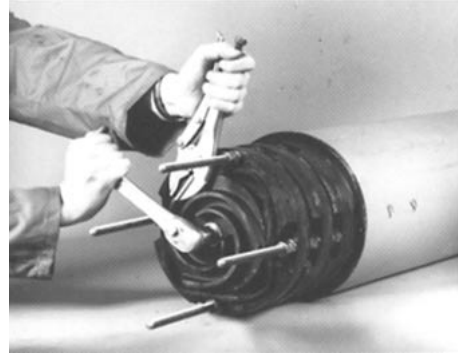
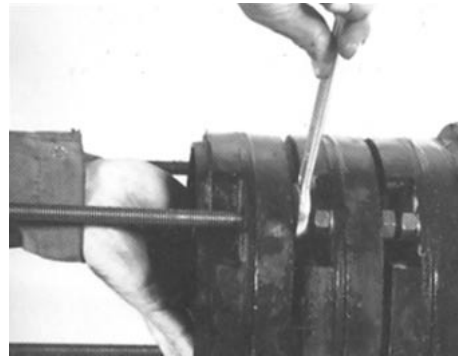

FAULT TRACING (TROUBLESHOOTING)

A universal instrument (VOM), a test lamp (continuity tester) and a wiring diagram are required in order to carry out fault tracing on the electrical equipment.

Fault tracing shall be done with the power supply disconnected and locked off, except for those checks which cannot be performed without voltage.

Always make sure that there is no one near the pump when the power supply is turned on.

Use the following checklist as an aid to fault tracing. It is assumed that the pump and installation have formerly functioned satisfactorily.



Electrical work shall be performed by an authorized electrician.

Follow local safety regulations and observe recommended safety precautions.

1. Pump fails to start

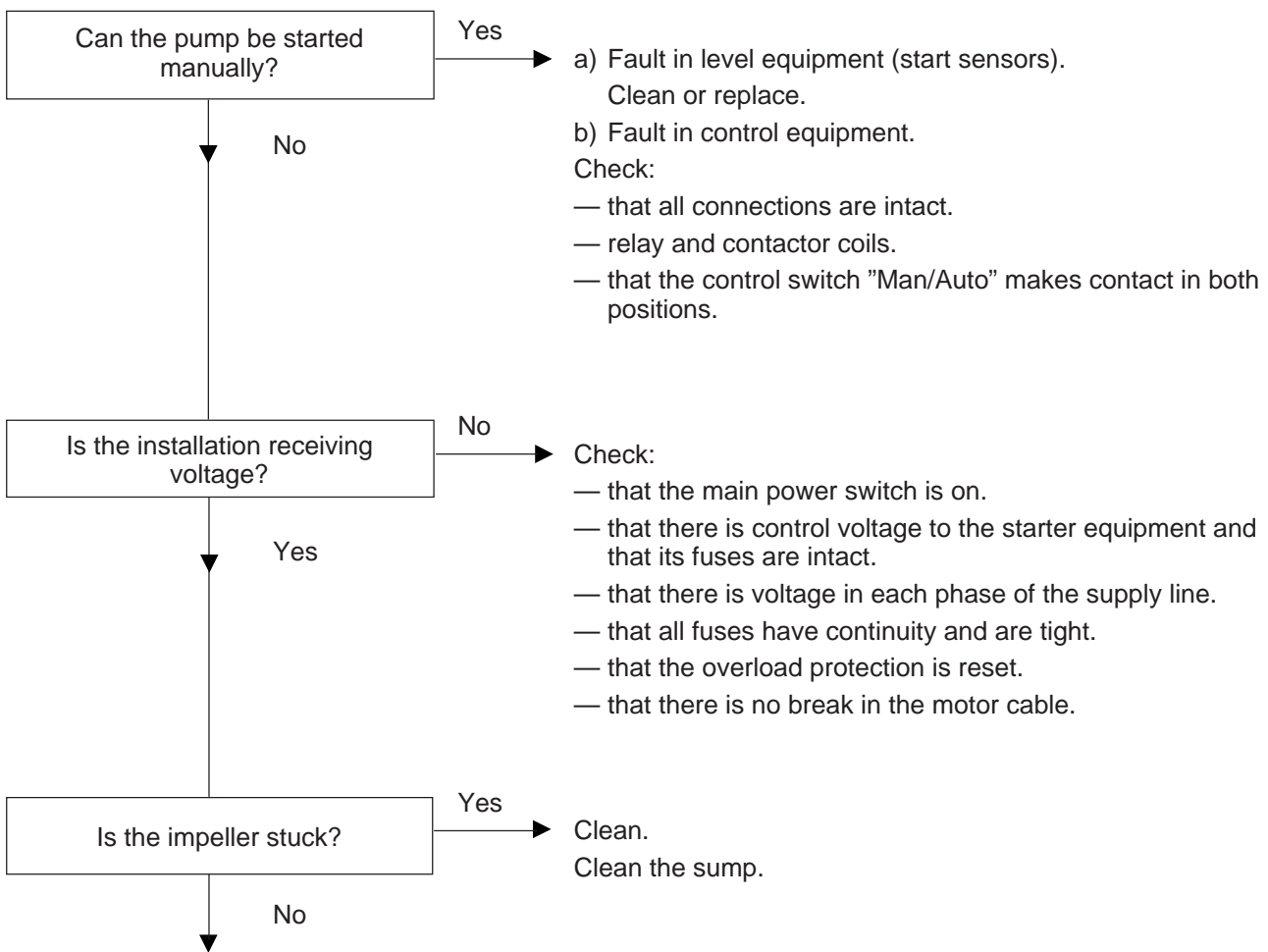

Contact Flygt service shop.



WARNING: disconnect power before checking the impeller.

2. Pump starts but motor protection trips

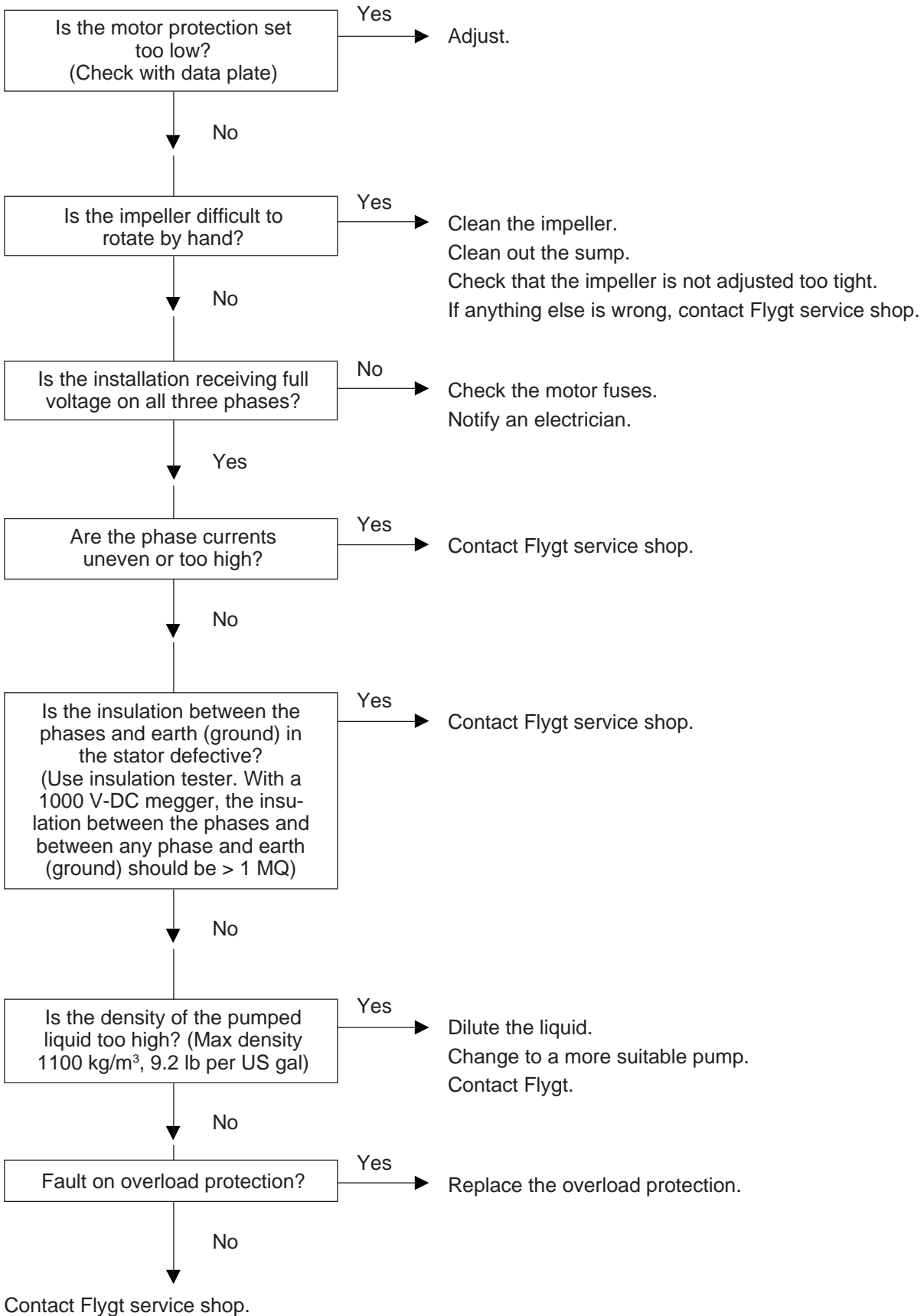



WARNING: disconnect power before checking the impeller.

3. The pump does not stop

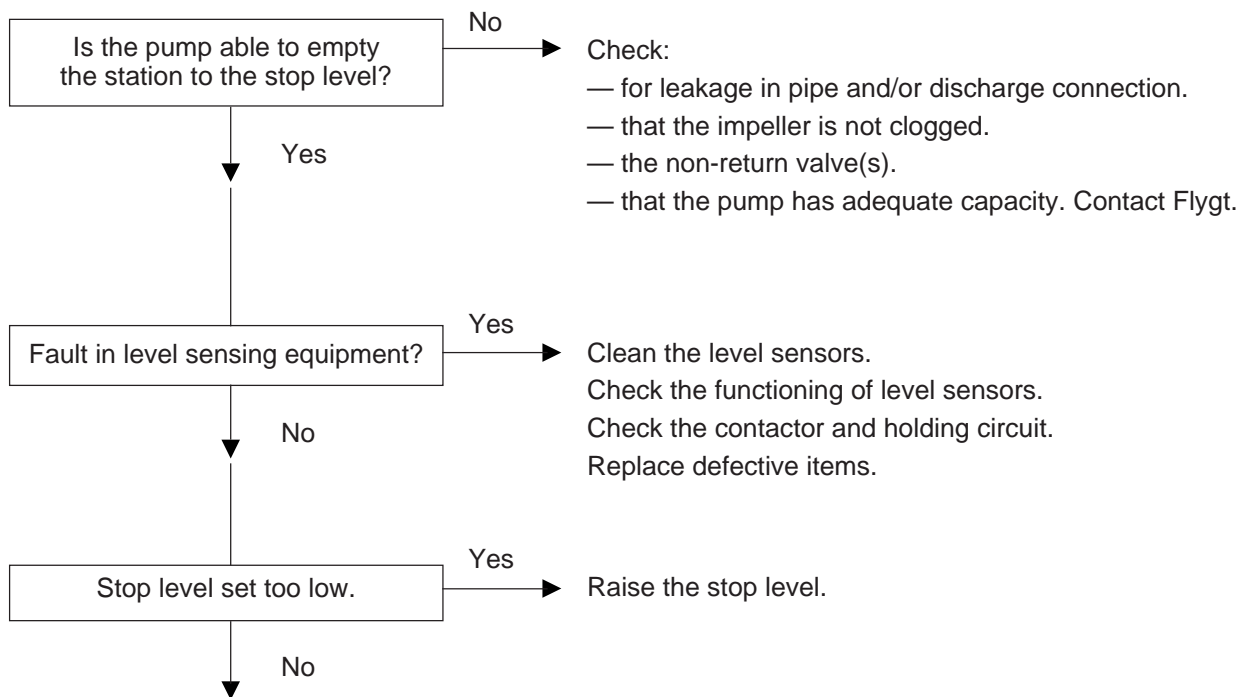

Contact Flygt service shop.



4. The pump starts-stops-starts in rapid sequence

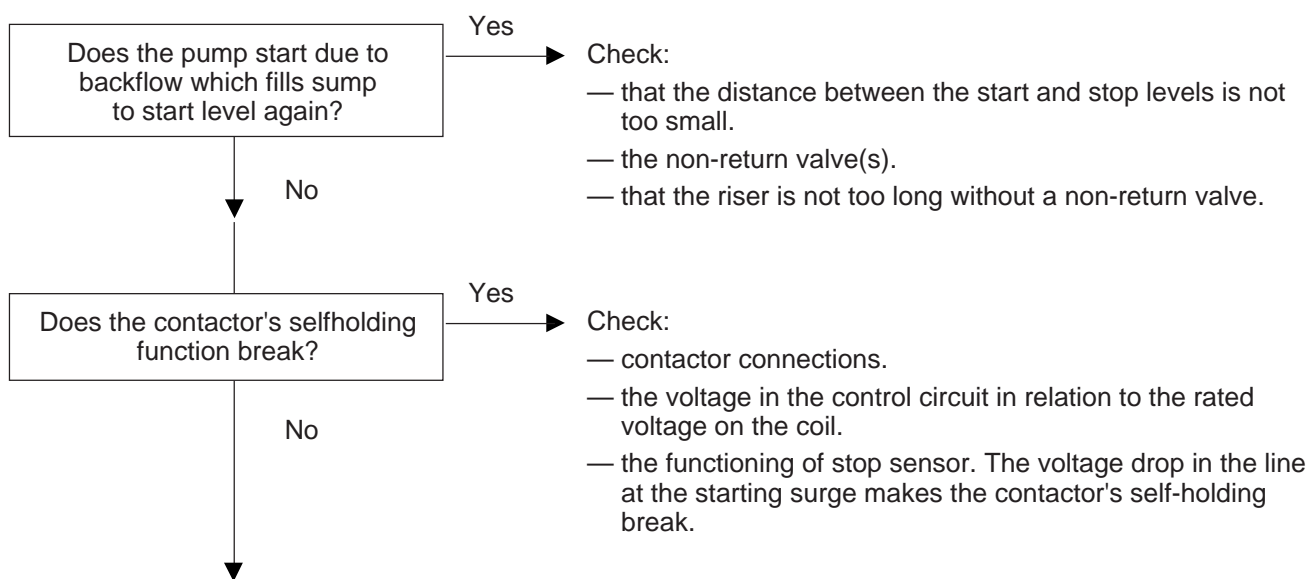

Contact Flygt service shop.

5. Pump runs but delivers too little or no water

Check:

- direction of rotation of pump, see “Before starting”.
- that valves are open and intact.
- that pipes, impeller and strainer are not clogged.
- that the impeller rotates easily.
- that the suction lift has not been altered.
- for leakage in the pump installation.
- for wear on wear ring, impeller, pump casing/flange, suction bottom, diffuser disc, diffuser.

See also under “Inspection”.

Do not override the motor protection repeatedly if it has tripped.

ACCESSORIES AND TOOLS

Tandem operation

The delivery head can be increased by connecting two or three pumps in tandem.

Max. permissible operating pressure is 1.5 MPa (218 psi).

The vertical distances between the pumps should be approximately equal.

See special brochure that describes the procedure for tandem connection.

The following complete connection units are available for tandem connection:

Order No.	Intended for
338 68 01	R3" (LT, MT)
338 68 02	R3" (HT)
338 68 03	NPSM 3—8 (LT, MT)
338 68 04	NPSM 3—8 (HT)

To make tandem connection possible, following strainers should be used:

Order No.	Intended for
406 68 03	LT
406 68 04	MT
406 68 05	HT

Zinc anode set

In order to reduce corrosion on the pump, it can be fitted with zinc anodes.

Order No. 429 91 00

Level sensor

Flygt supplies level sensors suited for different liquid densities and with different cable lengths.

See separate brochure.

Start and control equipment

Flygt has suitable start and control equipment for the pump. Contact Flygt for further information.

Tools

Besides ordinary standard tools, the following tools are required in order to perform the necessary care and maintenance of the pump:

Order No.	Description
84 13 60	Puller
84 20 49	Puller
84 13 61	Extra long jaw
84 14 45	Extra long jaw
427 07 00	Puller
398 22 00	Seal tool

For further information on tools, see Flygt's Tool Catalogue.

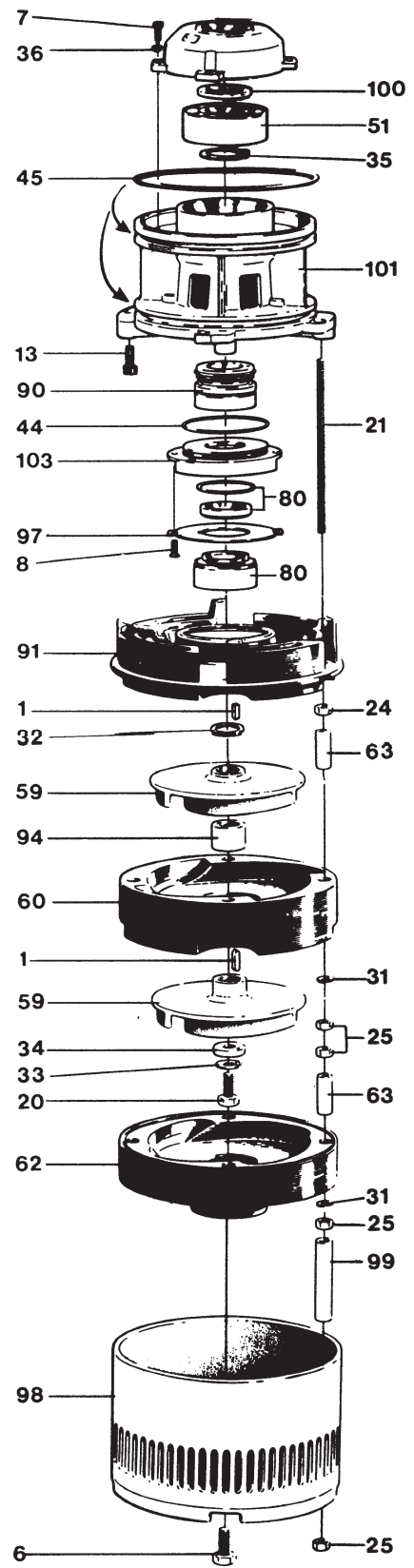
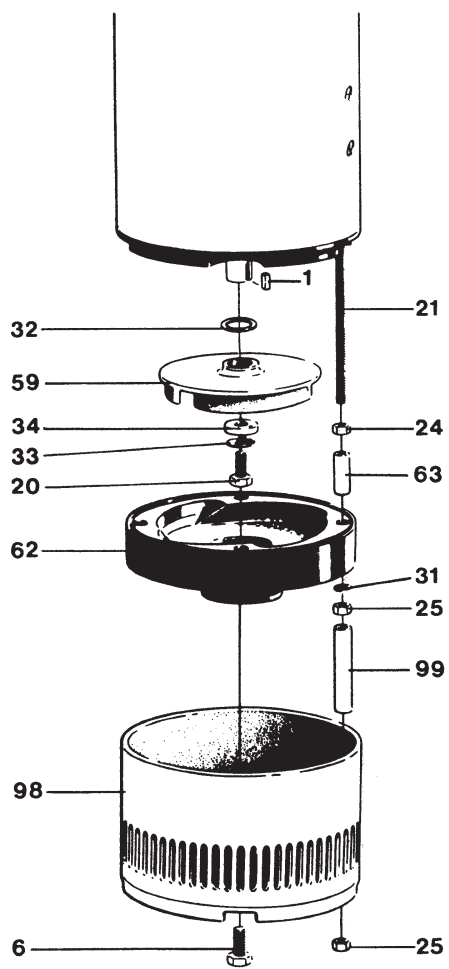

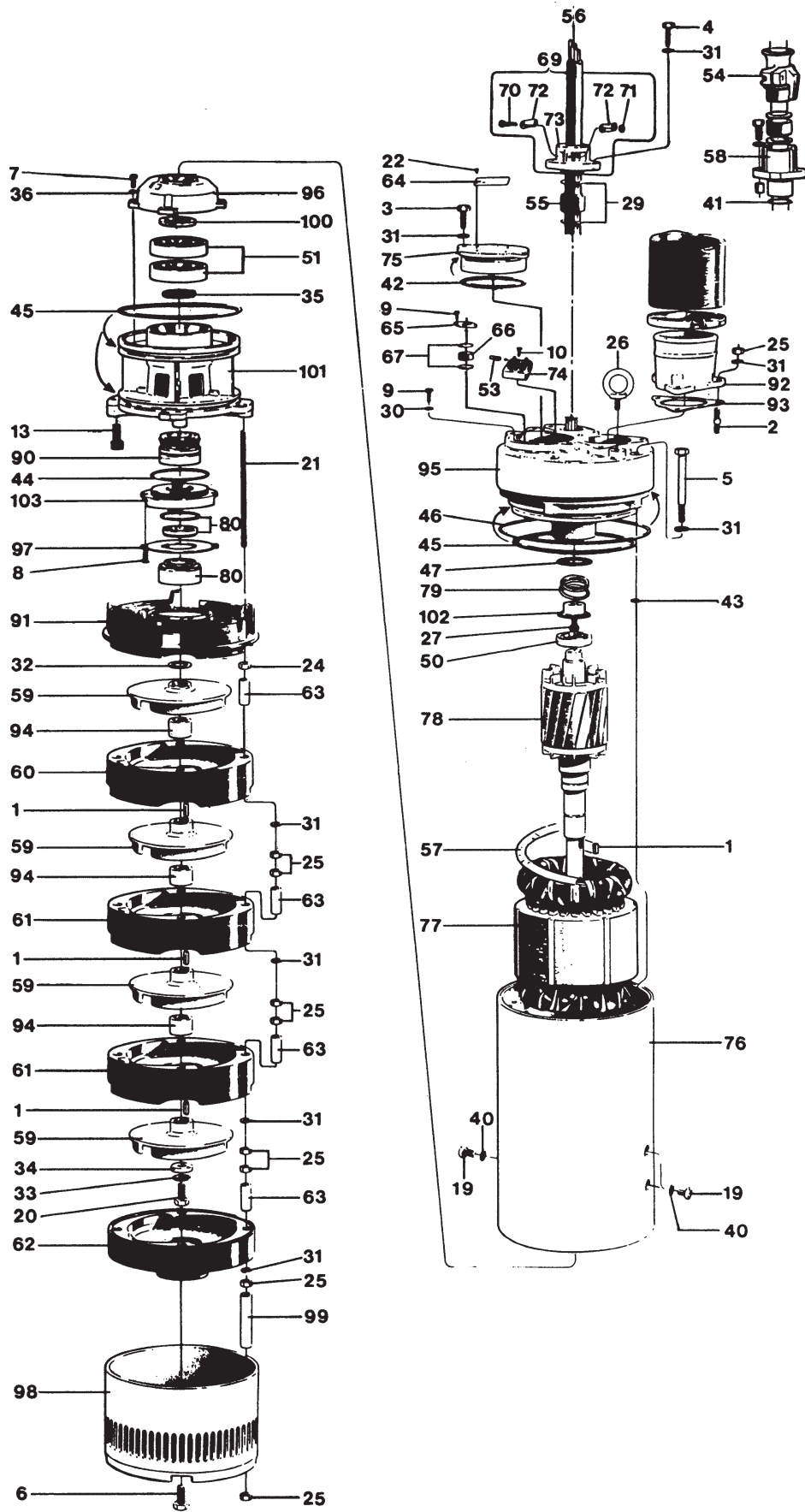



www.flygt.com