



Installation, care and maintenance

2071.010, 2071.010-U, 2071.010-W



GUARANTEE

Flygt undertakes to remedy faults in products sold by Flygt provided:

- that the fault is due to defects in design, materials or workmanship;
- that the fault is reported to Flygt or Flygt's representative during the guarantee period;
- that the product is used only under conditions described in the care and maintenance instructions and in applications for which it is intended;
- that the monitoring equipment incorporated in the product is correctly connected;
- that all service and repair work is done by a workshop authorized by Flygt;

— that genuine Flygt parts are used.

Hence, the guarantee does not cover faults caused by deficient maintenance, improper installation, incorrectly executed repair work or normal wear and tear.

Flygt assumes no liability for either bodily injuries, material damages or economic losses beyond what is stated above.

Flygt guarantees that a spare parts stock will be kept for 10 years after the manufacture of this product has been discontinued.

The manufacturer reserves the right to alter performance, specification or design without notice.

DATA PLATE INTERPRETATION

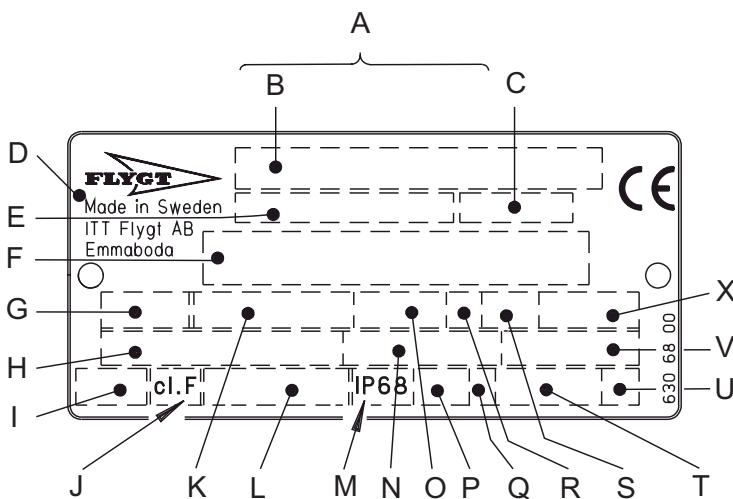

- A Serial number
- B Product code + Number
- C Curve code / Propeller code
- D Country of origin
- E Product number
- F Additional information
- G Phase; Type of current; Frequency
- H Rated voltage
- I Thermal protection
- J Thermal class
- K Rated shaft power
- L International standard
- M Degree of protection
- N Rated current
- O Rated speed
- P Max. submergence
- Q Direction of rotation: L=left, R=right
- R Duty class
- S Duty factor
- T Product weight
- U Locked rotor code letter
- V Power factor
- X Max. ambient temperature

CONTENTS

PRODUCT DESCRIPTION _____	3	OPERATION _____	11
Applications _____	3	Before starting _____	15
Dimensions and weights _____	3	CARE AND MAINTENANCE _____	12
Motor data _____	3	Safety precautions _____	12
Materials _____	3	Inspection _____	12
Design _____	4	Recommended inspections _____	12
Performance curves _____	5	Changing the oil _____	14
TRANSPORTATION AND STORAGE _____	6	Removing the impeller _____	14
INSTALLATION _____	6	Installing the impeller _____	15
Safety precautions _____	6	FAULT TRACING (TROUBLESHOOTING) _	18
Handling equipment _____	6	ACCESSORIES AND TOOLS _____	21
Pump installation _____	6	SERVICE LOG _____	22
ELECTRICAL CONNECTIONS _____	7	EXPLODED VIEW _____	23

PRODUCT DESCRIPTION

Applications

2071.010 is intended to be used for pumping of water which may contain abrasive particles.

The pump is available in the following versions:

LT = lowhead version

MT = mediumhead version

Liquid temperature: max. 40°C (105°F)

The pump is also available in a version (2071.010-W) for liquid temperatures up to 70°C (160°F) and in a version (2071.010-U) with POLY-LIFE wear parts for extra resistance.

2071-010-W has certain operational limitations, which are stated on a plate on the pump.

Liquid density: max. 1100 kg/m³ (9.2 lb per US gal.)

The pumped liquid may contain particles up to a size which corresponds to the openings in the strainer.

The pH of the pumped liquid: 5—8.

Depth of immersion: max. 20 m (66 ft).

For other applications, contact your nearest Flygt representative for information.



WARNING!
The pump may not be used in an explosive or flammable environment or for pumping flammable liquids.

Dimensions and weights

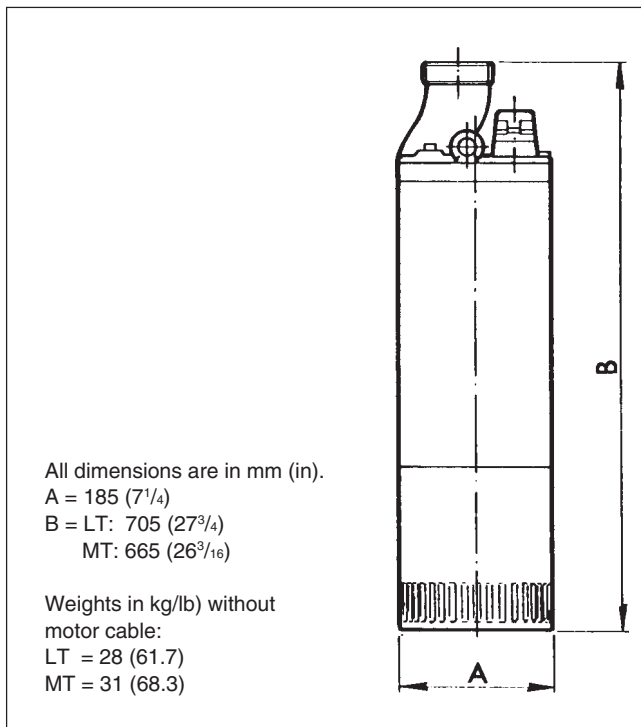

Motor data

3-phase motor

Motor type: Squirrel-cage AC motor, insulation class F

Rated output: 3.0 kW, 3 ~, 50 Hz, 2800 r/mn

Voltage V	Rated current A	Starting current A
220	11.0	60.1
380	6.6	34.6
400	6.3	30.0
415	6.0	31.0
440	5.7	32.9
500	5.0	24.7
550	4.6	27.1
660	3.8	20.0

Rated output: 5.0 kW (6.2 hp), 3 ~, 60 Hz, 3335 r/mn

Voltage V	Rated current A	Starting current A
230	16.0	78.0
460	8.0	43.0
575	6.5	29.0
600	6.2	30.0

Rated output: 3.0 kW (4.2 hp), 1 ~, 60 Hz, 3425 r/mn

Voltage V	Rated current A	Starting current A
230	18.0	67.5

Materials

		DIN	BS	AISI
Cast parts:	Aluminium (Hydronalium)	G-Al Mg5	1490	~SEA320
		Si 1	LM 5	
Shaft:	Stainless steel	1.4460	—	329
Impeller:	1) Forged and hardened spring steel	1.8159	735 A50	6150
	2) Forged stainless steel	1.4571	A 12 Ti	316 Ti
Hydraulic parts:		Nitrile-rubber-covered		
POLY-LIFE version:		Polyurethane-lined		
Seal surfaces, inner seal:		Tungsten carbide— Tungsten carbide, WCCR		
Seal surfaces, outer seal:		Tungsten carbide— Tungsten carbide, WCCR		



NOTE!
Make sure that the monitoring equipment incorporated in the product is correctly connected.

Design

1. Junction box

The junction box is completely sealed off against the surrounding liquid and against the motor unit.

2. Cooling

The pumped liquid is circulated from the pump casing up between the cooling jacket and the stator casing and carries away the heat generated by the motor.

3. Motor

Motor insulation to Class F means a maximum working temperature of 155°C (310°F) and permits a temperature rise of 100°C (210°F).

The temperature rise in Flygt motors does not normally exceed 80°C (175°F). The insulation material is chosen with the greatest care, and most materials are classified as Class H (180°C, 355°F) materials or very close to Class H. This means an expected service life far beyond what is required for Class F.

4. Shaft seals

The pump has two pairs of mechanical seals with extremely wearresistant seal surfaces.

The seals work independently of each other and seal off the motor from the pump unit.

5. Impellers

The LT version is equipped with one impeller and the MT version has two impellers in series.

The impellers can be chosen in two different material variants.

6. Wear parts

The pump's easily replaceable wear parts are rubber-covered.

By means of a simple fine adjustment, the pump's capacity can be maintained despite heavy wear.

When the parts are finally worn out, replacement is an easy matter.

7. Oil casing

The oil lubricates and cools the seals and acts as a buffer between the pump casing and the electric motor.

Pressure build-up within the oil casing is reduced by means of a builtin air volume.

8. Bearings

The upper bearing consists of a single row ball bearing.

The lower bearing consists of a double row angular contact ball bearing.

9. Monitoring equipment

The stator incorporates two thermal switches connected in series. The thermal switches open at 125°C (260°F).

The monitoring equipment shall be of a design that makes automatic restart impossible.

See also "Electrical connections" and separate instructions for starter equipment.

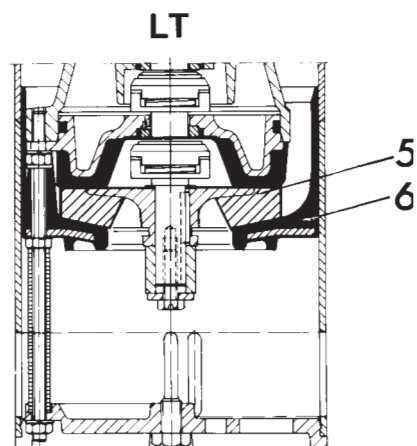
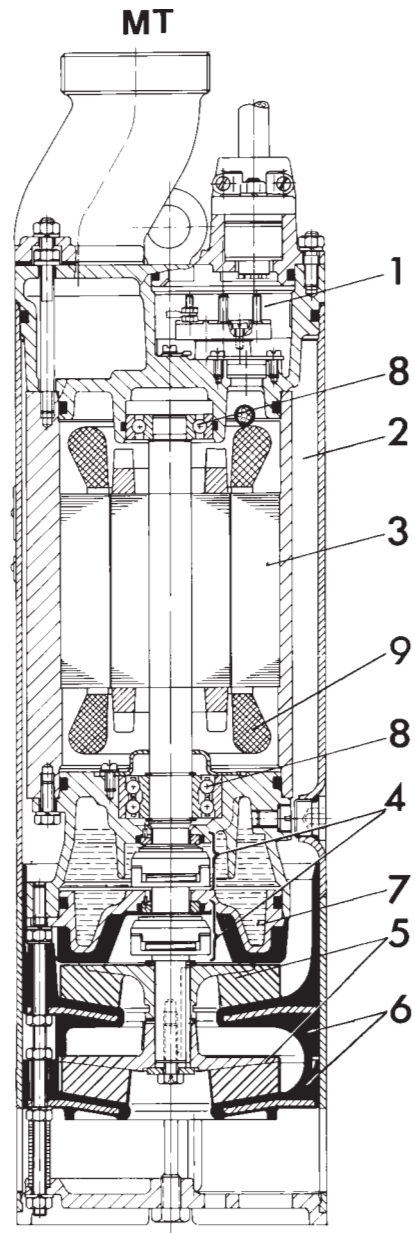

NOTE!
Make sure that the monitoring equipment incorporated in the product is correctly connected.

Performance curves

LT = Low-head version

MT = Medium-head version

▭ = Best operating point

50 Hz, 3-phase

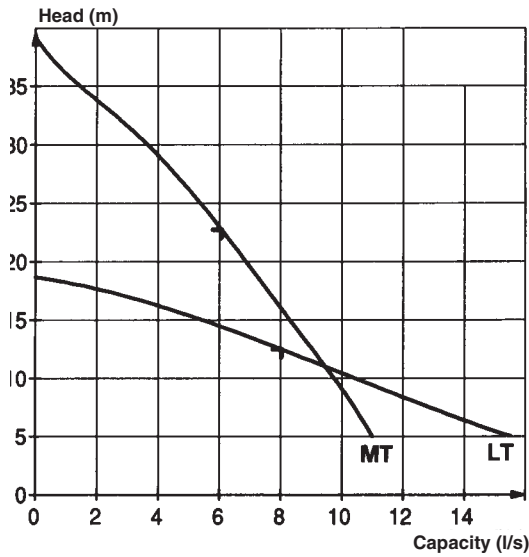
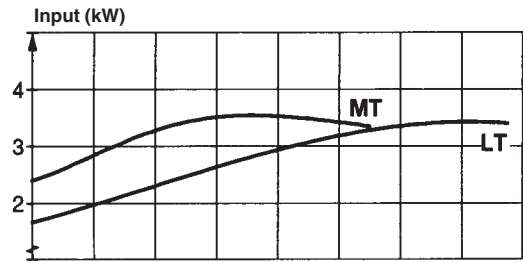

60 Hz, 3-phase

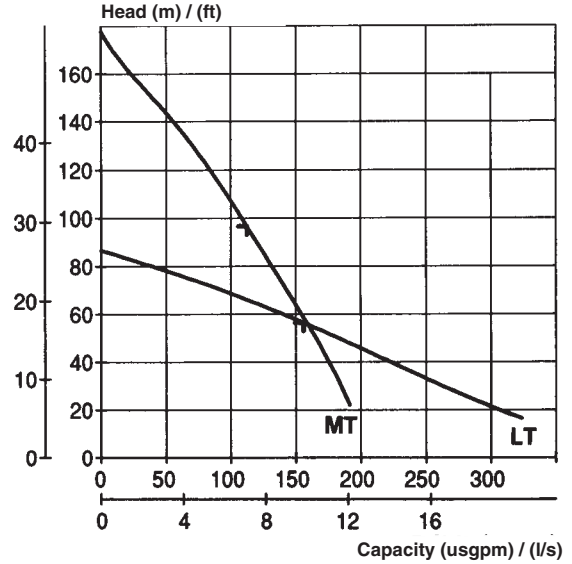
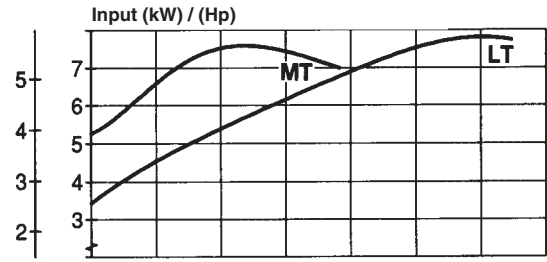

60 Hz, 1-phase

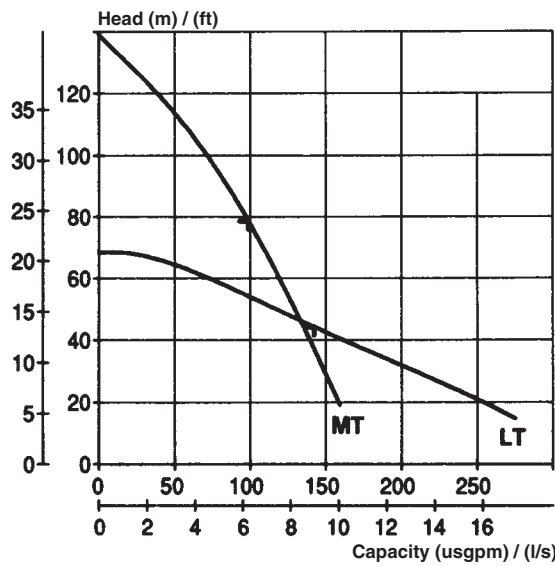
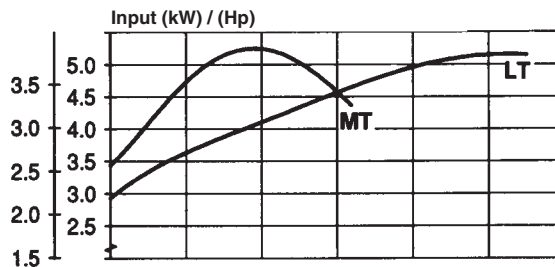

TRANSPORTATION AND STORAGE

The pump may be transported and stored in a vertical or horizontal position. Make sure that it cannot roll or fall over.



WARNING!
Always lift the pump by its lifting eyes, never by the motor cable or the hose.

The pump is frostproof as long as it is operating or is immersed in the liquid. If the pump is taken up when the temperature is below freezing, the impeller may freeze. The pump shall be operated for a short period after being taken up in order to expel all remaining water.

A frozen impeller can be thawed by allowing the pump to stand immersed in the liquid for a short period before it is started. Never use an open flame to thaw the pump.

For longer periods of storage, the pump must be protected against moisture and heat. The impeller should be rotated by hand occasionally (for example every other month) to prevent the seals from sticking together. If the pump is stored for more than 6 months, this rotation is mandatory.

After a long period of storage, the pump should be inspected before it is put into operation. Pay special attention to the seals and the cable entry.

Follow the instructions under the heading "Before starting".

INSTALLATION

Safety precautions

In order to minimize the risk of accidents in connection with the service and installation work, the following rules should be followed:

1. **Make sure the lifting equipment is in good condition.**
2. **Be aware of the risk of electrical accidents.**
3. **Use a safety helmet, safety goggles and protective shoes.**
4. **Do not ignore the risk of drowning.**
5. **A first-aid kit must be handy.**



At certain installations and operation points on the pump curve the noise level 70 dB, or for the actual pump specified noise level, can be exceeded.

Handling equipment

Lifting equipment will facilitate handling of the pump.
WARNING! Keep out from under suspended loads.

Pump installation

Run the cables so that they do not have any sharp bends and are not pinched.

Connect the discharge connection and motor cable. See "Electrical connections".

Lower the pump into the sump.

Place the pump on a base which will prevent it from sinking into a soft sump bottom. Alternatively, the pump can be suspended by its handle just above the sump bottom.

For tandem connection of pumps, see "Accessories and tools".

— choice of ancillary equipment.

— other problems in connection with installation.

ELECTRICAL CONNECTIONS

All electrical work shall be carried out under the supervision of an authorized electrician.

Local codes and regulations shall be complied with.



WARNING!

All electrical equipment must be earthed. This applies to both pump equipment and any monitoring equipment. Failure to heed this warning may cause a lethal accident. Make sure that the earth lead is correctly connected by testing it.

Check that the mains voltage and frequency agree with the specifications on the pump data plate.

The motor can be connected for different voltages as shown on the data plate.

Under no circumstances may the starter equipment be installed in the pump pit.

Install the motor cable and the control cables as illustrated in the figure.

To avoid leakage into the pump, check:

- that the cable entry seal sleeve and washers conform to the outside diameter of the cable. See the parts list.
- that the outer jacket on the cable is not damaged. When refitting a cable which has been used before, **always** cut off a short piece of the cable so that the cable entry seal sleeve does not close around the cable at the same point again.



WARNING!

For safety reasons, the earth lead should be approx. 70 mm (2.8") longer than the phase leads. If the motor cable is jerked loose by mistake, the earth lead should be the last lead to come loose from its terminal. This applies to both ends of the cable.

Check in the data plate which connection Y or Δ , is valid for the voltage supply. Then, depending on voltage, arrange the connection on the terminal board in accordance with Y or Δ .

Connect the motor cable to the terminal board connections U1, Vi, W1 and earth.

Connect the leads from the motor control circuit to T1 and T2 (not shown in figure).

Make sure that the pump is correctly earthed (grounded).

Install the cover (46).

Tighten the nuts (12) so that the cable entry unit bottoms out.

Connect the motor cable and the control cable to the starter equipment. Check the direction of rotation, see "Before starting".

If the direction of rotation is wrong, transpose two of the phase leads.

For 1-phase pumps going in wrong direction, please contact your nearest Flygt representative.

Remember that the starting surge with the direct-on line start can be up to six times higher than the rated current. Make sure that the fuses or circuit breakers are of the proper amperage.

The table (page 3) gives rated current and starting current. Fuse amperage and cable shall be selected in accordance with local rules and regulations. Note that with long cables, the voltage drop in the cable must be taken into consideration, since the motor's rated voltage is the voltage that is measured at the terminal board in the pump.

The overload protection (motor protection breaker) shall be set to the motor's operating current, but no higher than the motor's rated current as given on the data plate.



NOTE!

Make sure that the monitoring equipment incorporated in the product is correctly connected.

Electrical connections

50/60 Hz, 3~ with terminal board

SUBCAB/SUBCAB AWG*: (4G+2x1,5)

Mains	Lead	Pump terminal board
L1	Brown (Red*)	U1
L2	Blue (White*)	W1
L3	Black (Black*)	V1
Earth (PE)	Yellow/Green	⏏
Groundcheck	Yellow*	GC
T1	Black (Orange*)	T1
T2	Black (Blue*)	T2

The stator leads are connected to the terminal board as follows:

Stator lead	Connection on terminal board
U1, red	U1 (S1)
V1, brown	V1 (S2)
W1, yellow	W1 (S3)
V2, blue	V2 (S4)
W2, black	W2 (S5)
U2, green	U2 (S6)

Connect the control leads from the motor control circuit to T1 and T2.

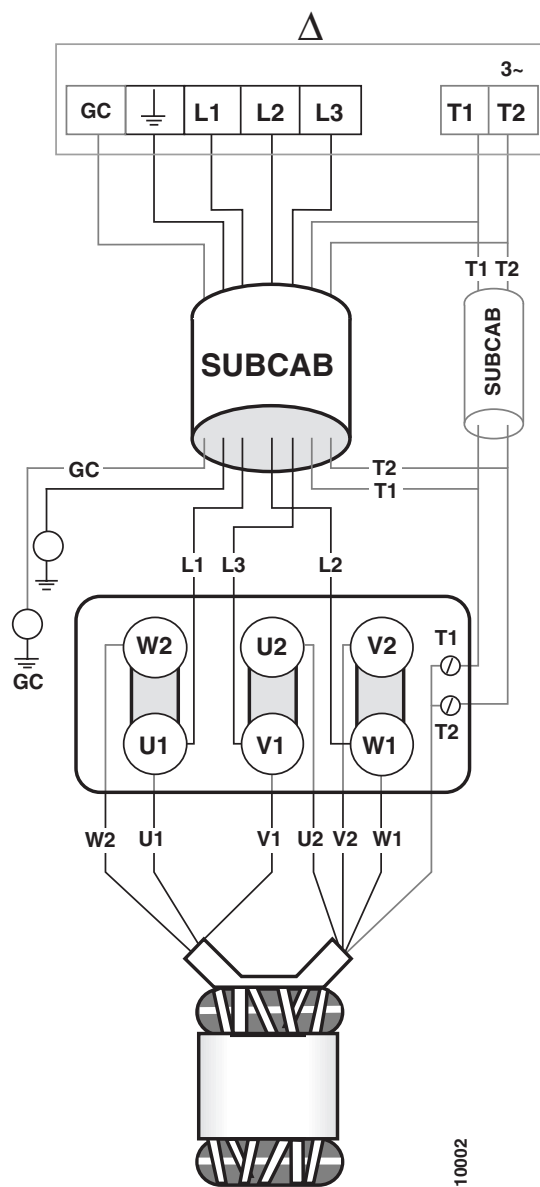
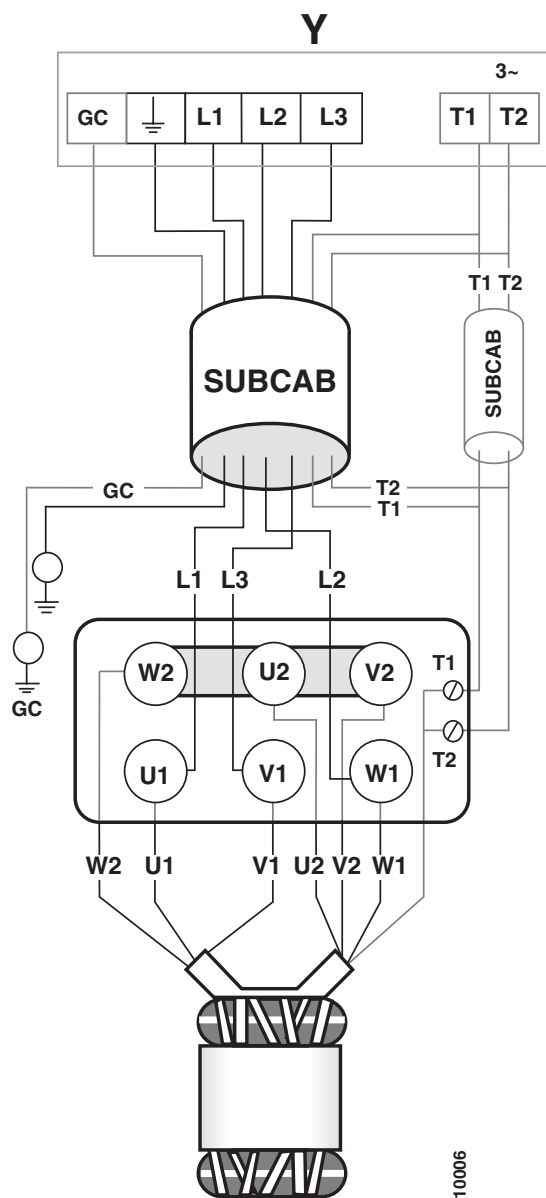

Electrical connections

SUBCAB/SUBCAB AWG*:

Mains	Lead	Pump terminal board
L1	Brown (Red*)	U1
L2	Blue (White*)	W1
L3	Black (Black*)	V1
Earth (PE)	Yellow/Green	⏚
Groundcheck	Yellow*	GC
T1	Black/Orange*	T1
T2	Black/Blue*	T2

Connect the control leads from the motor control circuit to T1 and T2.

The stator leads are colour-marked as follows:

- U1 (S1) — red
- V1 (S2) — brown
- W1 (S3) — yellow
- U2 (S4) — green
- V2 (S5) — blue
- W2 (S6) — black
- U5 (S7) — red
- V5 (S8) — brown
- W5 (S9) — yellow
- U6 (S10) — green
- V6 (S11) — blue
- W6 (S12) — black

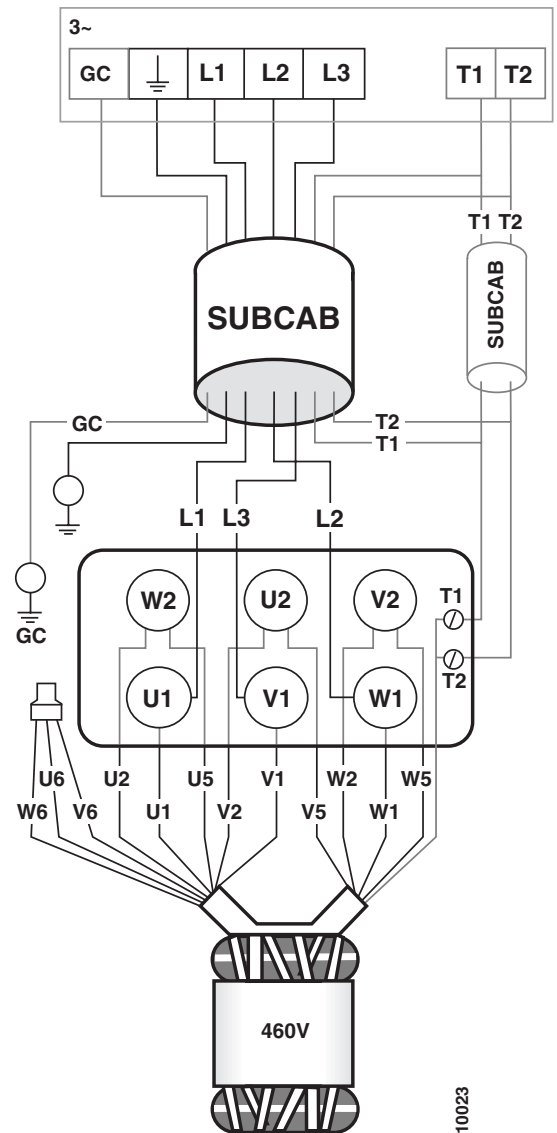
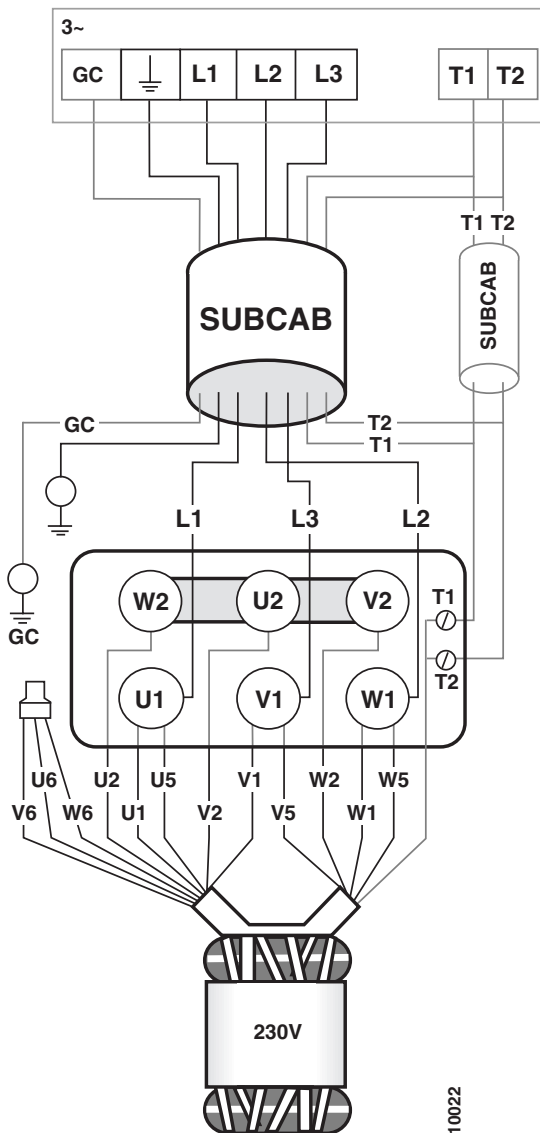

Electrical connections

60 Hz, 1~ with terminal board

SUBCAB/SUBCAB AWG*:

No.	Lead	Pump terminal board
1	Red	U1
2	Black	W1
3	White	V1
Earth (PE)	Yellow/Green	⏏

The stator leads are colour-marked as follows:

U1 (S1)	— red
V1 (S2)	— brown
W1 (S3)	— yellow
U2 (S4)	— green
V2 (S5)	— blue
W2 (S6)	— black
U5 (S7)	— red
V5 (S8)	— brown
W5 (S9)	— yellow
U6 (S10)	— green
V6 (S11)	— blue
W6 (S12)	— black

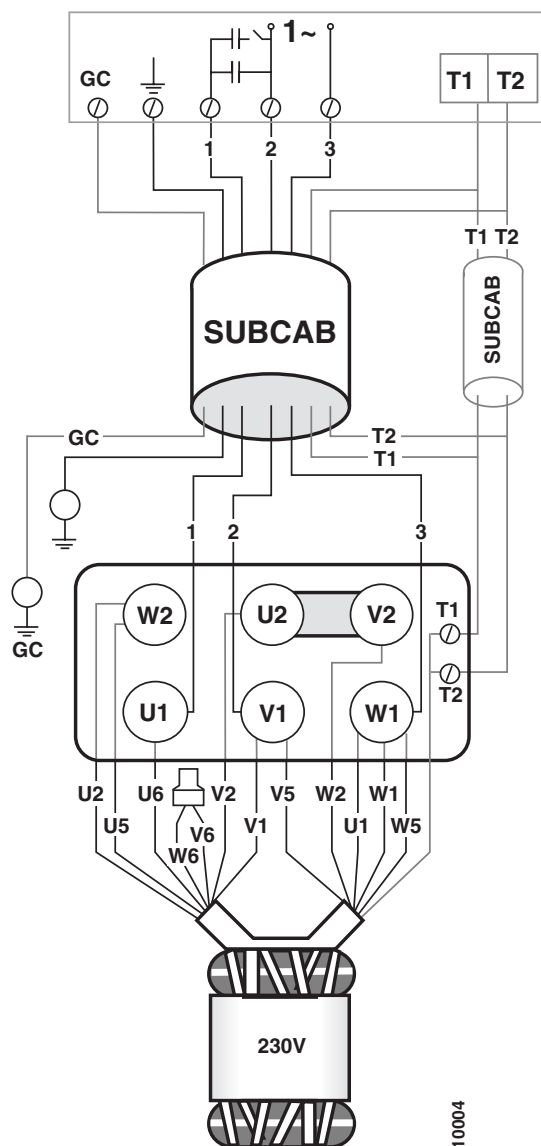

10004

OPERATION

Before starting

Remove the fuses or open the circuit breaker and check that the impeller can be rotated by hand.

Check the oil level in the oil casing.

Check that the monitoring equipment (if any) works.

Check the direction of rotation. The impeller shall rotate clockwise, as viewed from above. When started, the pump will jerk in the opposite direction to the direction in which the impeller rotates. See the figure.



WARNING!
Watch out for the starting jerk,
which can be powerful.

The above measures are described under "Inspection".

Starting jerk

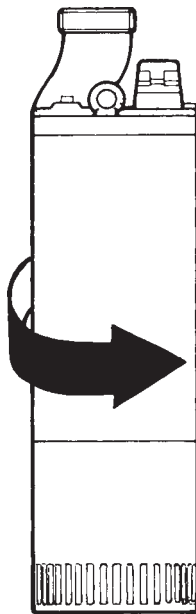

Avoidance of sedimentation

In order to avoid sedimentation when the pumped liquid contains solid particles, the velocity of the medium in the discharge line should be:

Mixture	Min. velocity in discharge line
1. Water + coarse gravel	4 m/s (13.2 ft/s)
2. Water + gravel	3.5m/s (11.5 ft/s)
3. Water + sand	
Sand particles < 0.1 m m (0.004 in)	1.5 m/s (5.0 ft/s)
Sand particles < 0.6 m m (0.024 in)	2.5 m/s (8.2 ft/s)

The pump can be provided with level regulation in order to prevent unnecessary wear on the hydraulic components.

Cleaning

If the pump has been running in very dirty water, let it run for a while in clean water, or flush it through the discharge connection. If clay, cement or other similar dirt is left in the pump it may clog the impeller and seal preventing the pump from working.

During a longer period out of operation, the pump must be test run every other month to prevent the mechanical seals from sticking together.

CARE AND MAINTENANCE

The figures in parentheses are item numbers and refer to the exploded view drawing.

Safety precautions



WARNING!
Before starting work on the pump, make sure that the pump is isolated from the power supply and cannot be energized.

NOTE! This applies to the control circuit as well.

The following points are important in connection with work on the pump:

- make sure that the pump has been thoroughly cleaned.
- observe good personal hygiene.
- follow local safety regulations.

Inspection

Regular inspection and preventive maintenance ensure more reliable operation.

The pump should be inspected at least twice a year, more frequently under severe operating conditions.

Under normal operating conditions, the pump should have a major overhaul in a service shop once a year.

This requires special tools and should be done by an authorized service shop.

When the pump is new or when the seals have been replaced, inspection is recommended after one week of operation.

Service contract

Flygt or its agent offers service agreements in accordance with a preventive maintenance plan. For further information, please contact your Flygt representative.

Recommended inspections:

Inspection of	Action
Visible parts on pump and installation	Replace or fix worn and damaged parts. Make sure that all screws, bolts and nuts are tight. Check the condition of carrying handle/lifting eyes, chains and wire ropes.
Pump casing and impeller	Replace worn parts if they impair function. Wear on the impeller and the parts around it necessitates fine adjustment of the impeller or replacement of worn parts. See "Replacing the impeller" and "Replacing the diffuser".
Oil quantity	Oil casing



WARNING! If the seal leaks, the oil casing may be under pressure. Hold a rag over the oil plug in order to prevent splatter. See "Safety precautions" for additional information.

Check that the oil reaches up to the oil hole.

Add oil as needed. See "Changing the oil".

Inspection of	Action
Condition of the oil	<p>A check of the condition of the oil can show whether there has been an increased leakage. Note! Air/oil mixture can be confused with water/oil mixture.</p> <p>Insert a tube (or hose) into the oil hole. Cover the top end of the tube and take up a little oil from the bottom.</p> <p>Change the oil if it contains too much water, i.e., is heavily emulsified (creamlike), or if the oil housing contains separated water. See "Changing the oil". Check again one week after changing the oil. If the oil contains too much water again, the fault may be:</p> <ul style="list-style-type: none"> — that an oil screw (41) is not sufficiently tight. — that the O-ring (31) of an oil screw or its sealing surface is damaged. — that an O-ring (26) or its sealing surface is damaged. — that the lower mechanical seal (77) is damaged. <p>Contact a Flygt service shop.</p>
Cooling system	Rinse and clean if the flow through the system has been partly restricted.
Cable entry	<p>Make sure that the cable clamps are tight. If the cable entry leaks:</p> <ul style="list-style-type: none"> — check that the entry is firmly tightened into its bottom-most position. — cut a piece of the cable off so that the seal sleeve (36) closes around a new position on the cable. — replace the seal sleeve (36). — check that the seal sleeve (36) and the washers (15) conform to the outside diameter of the cables.
Cables	Replace the cable if the outer jacket is damaged. Make sure that the cables do not have any sharp bends and are not pinched.
Level sensors or other level equipment	<p>Check function. Clean, adjust, replace or repair damaged level sensing equipment. Follow the instructions for the level sensing equipment in question.</p> <p>NOTE! The level sensor (ENH-10) contains a mercury switch. Damaged sensors should therefore be disposed of in a proper manner.</p>
Starter equipment	If faulty, contact an electrician.
Rotation direction of pump (requires voltage)	Transpose two phase leads if the impeller does not rotate clockwise as viewed from above. Rotation in the wrong direction reduces the capacity of the pump and the motor may be overloaded. Check the direction of rotation, during non-load every time the pump is reconnected.
Pipes, valves and other peripheral equipment	Repair faults and notify supervisor of any faults or defects.
Insulation resistance in the stator	Use insulation tester. With a 1000 V-DC megger the insulation between the phases and between any phase and earth (ground) should be > 1 MΩ.

Changing the oil



Lay the pump on its side on a bench or over two supports.

Unscrew plug (22) at the mark "Oil out".



WARNING!
If the seal leaks, the oil casing may be under pressure. Hold a rag over the oil plug (41) to prevent splatter.



Unscrew the oil hole screw (41).

(A drainage tube no. 500 03 00 can be inserted into the hole to facilitate drainage of oil.) Turn the pump so that the oil hole faces downwards. Let the oil run out. Turn the pump so that the oil hole faces upwards.

Fill up with 0.4 litres (0.42 US quarts) of new oil. Always replace the O-ring of the oil hole screw. Put the screw back and tighten it. Tightening torque 10 Nm (7 ft-lbs).

A paraffin oil with viscosity close to ISO VG15 is recommended (e.g. Mobil Whiterex 309). The pump is delivered from factory with this type of oil.

In applications where poisonous properties are of less concern, a mineral oil with viscosity up to ISO VG32 can be used.

Removing the impeller



WARNING!
Worn impellers often have very sharp edges.

Lay the pump on its side.



Remove protection screw (7).



Remove nuts (12), washers (17).



Press of the strainer (75) with a long M12 screw (427 07 00).



Remove further sleeves (93), nuts (12) and washers (17). Pull of diffuser ring (91) on MT-version (sleeve 81 on LT-version).



Remove impeller screw (64), use a plier to lock impeller. Remove washer (42) (and sleeve 81 on LT-version).



Pull off the impeller.
Use a puller (84 20 48) or pry off carefully with two strong screwdrivers or bars. Remove adjusting washers (49, 51).

MT-version



Remove nuts (12).
Pull off the upper diffuser (94).
Insert a screwdriver or bar in the center hole of the diffuser and bend carefully.



Pull off the upper impeller (95). Use impeller puller (84 20 48) or pry off carefully with two strong screwdrivers or bars.

Remove adjusting washers (49, 51).

Installing the impeller

MT-version

Make sure that the end of the shaft is clean and free of burrs. Polish of any flaws with fine emery cloth.



Upper impeller

Check that the key (2) is seated in the keyway on the shaft.

Put adjusting washers (49, 51) on the shaft before the impeller. Fit the impeller (95).

Put sleeve (342 96 00) on the shaft and secure the impeller with washer (42) and screw (64).

Check that the impeller is firmly seated.

The clearance between the impeller and the oil housing bottom should be minimal when the impeller is tightened.

The clearance can be adjusted with the adjusting washers (49, 51).

Check that the impeller can easily be rotated by hand. Press the diffuser (94) against the impeller.

The diffuser (94) has 4 integrated rubber springs supported by the washer (14) against which the diffuser can be adjusted.



Place nuts (12) on the studs, and tighten them evenly all around.

The clearance between the impeller and the diffuser shall be as little as possible.

Check that the impeller can be rotated by hand.

Remove the impeller screw (64), washer (42) and sleeve (342 96 00).

Lower impeller



Put adjusting washers (49, 51) on the shaft.

Install the lower impeller and tighten it with washer (42) and impeller screw (64).

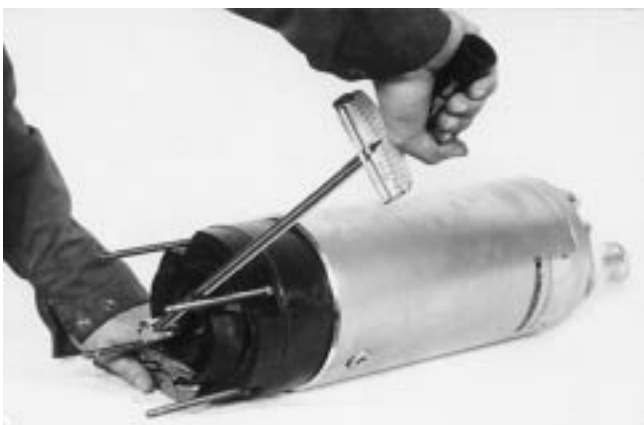

Tighten torque 20 Nm (15 ft-lbs).

The clearance between the impeller and the diffuser (94) should be minimal when the impeller is tightened.

The clearance can be adjusted with the adjusting washers (49, 51).



Check that the impeller can be easily rotated by hand. Screw the inner adjusting nuts (12) down toward the bottom of the studs (45).

Check that the spacing sleeves (92) are seated in the diffuser ring (91).

Press the diffuser ring (91) against the impeller.

Screw the inner adjusting nuts (12) so that they lie flush against the diffuser ring.

Back off all adjusting nuts another half-turn (counter clockwise).

Place nuts (12) and spring washer (17) on the studs.

Tighten the nuts (12) evenly all around.

The clearance between the impeller and the diffuser ring shall be as little as possible.



Check that the impeller can easily be rotated by hand. Grease the outside of the diffusers lightly.

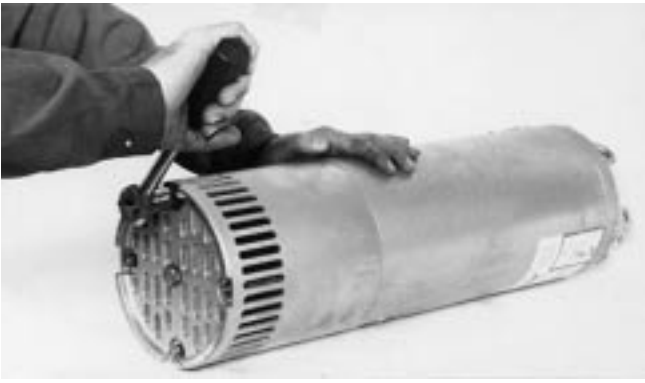

Install protective sleeves (93) strainer (75) and screw (7).

Tighten the strainer with washer (17) and locking nuts (12).

In order for the pump to perform at maximum capacity, the diffusers must be adjusted regularly.

LT-version



Make sure that the end of the shaft is clean and free of burrs. Polish off any flaws.

Check that the key (2) is seated in the keyway on the shaft.

Put adjusting washers (49, 51) on the shaft before the impeller.

Fit the impeller (84), sleeve (81), washer (42) and screw (64).

Tighten the impeller screw.

Tightening torque: 20 Nm (15 ft-lbs).

Check that the impeller is firmly seated.

The clearance should be minimal when the impeller is tightened.

The clearance can be adjusted with the adjusting washers (49, 51). Check that the impeller can be easily rotated by hand.



The diffuser (83) has 4 integrated rubber springs supported by washers (14) against which the diffuser can be adjusted.

Press the diffuser (83) against the impeller.

Place nuts (12) on the studs (45).

Tighten the nuts (12) evenly all around.

The clearance between the impeller and the diffuser shall be as little as possible.

Check that the impeller can easily be rotated by hand.



Grease the outside of the diffuser lightly.

Install protective sleeves (82), strainer (75) and screw (7).

Tighten the strainer with washer (17) and nut (12).

In order for the pump to perform at maximum capacity, the impeller must be adjusted regularly.

More extensive repairs require special tools and should be carried out by an authorized service technician.

FAULT TRACING (TROUBLESHOOTING)

A universal instrument (VOM), a test lamp (continuity tester) and a wiring diagram are required in order to carry out fault tracing on the electrical equipment.

Fault tracing shall be done with the power supply disconnected and locked off, except for those checks which cannot be performed without voltage.

Always make sure that there is no one near the pump when the power supply is turned on.

Use the following checklist as an aid to fault tracing. It is assumed that the pump and installation have formerly functioned satisfactorily.



Electrical work shall be performed by an authorized electrician.

Follow local safety regulations and observe recommended safety precautions.

1. Pump fails to start

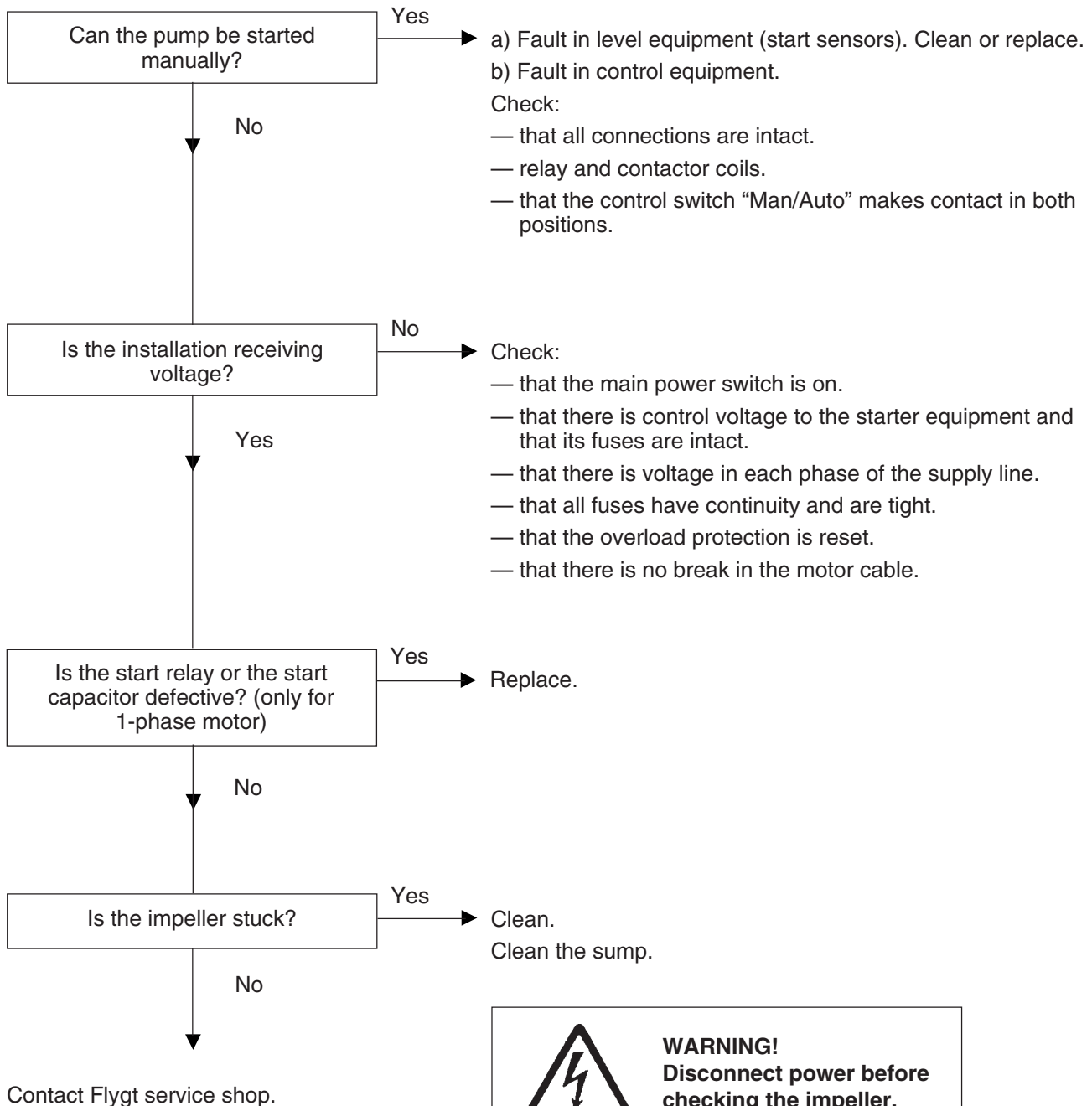

WARNING!
Disconnect power before checking the impeller.

2. Pump starts but motor protection trips

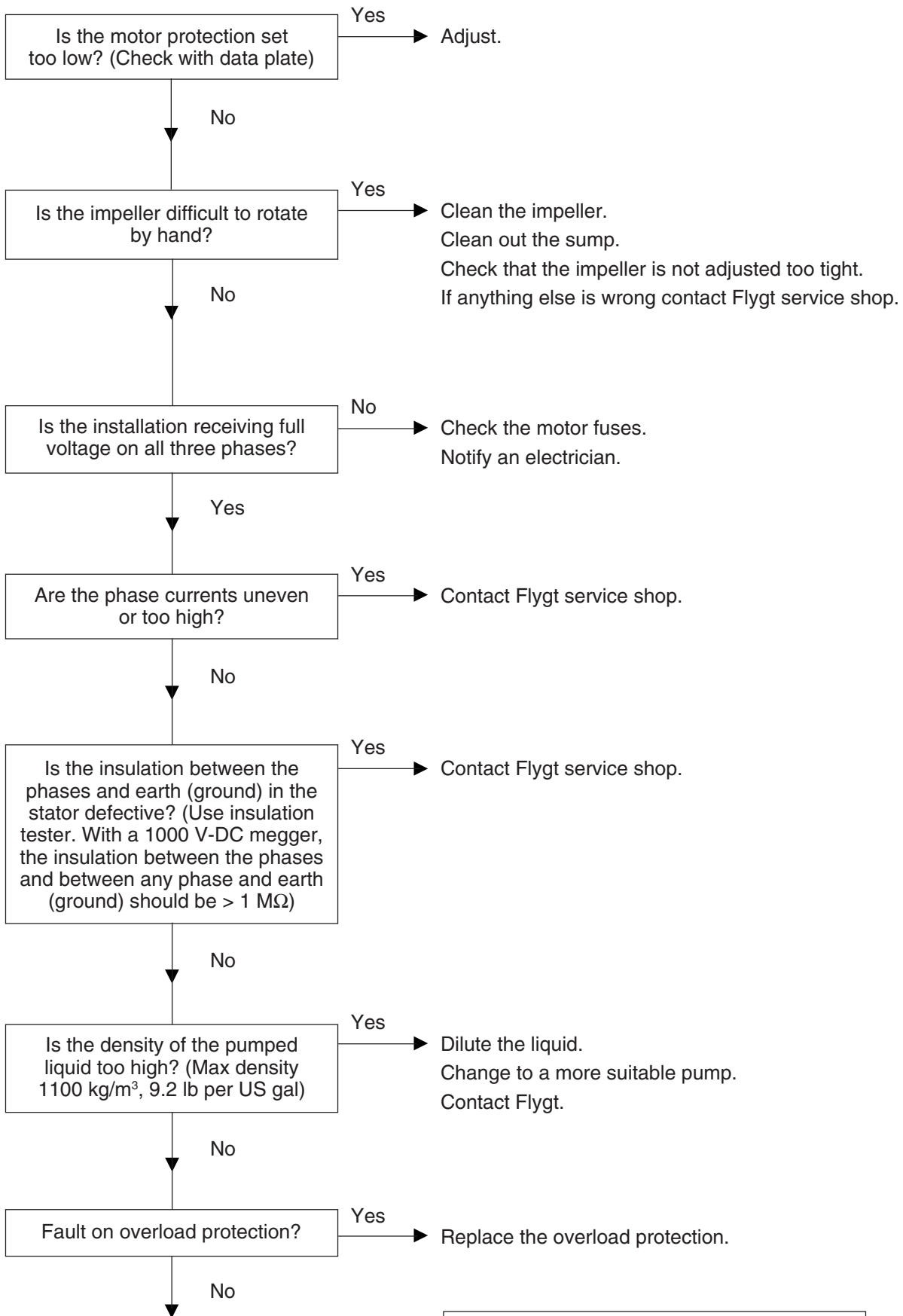

Contact Flygt service shop.

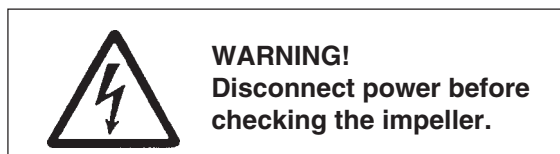

3. The pump does not stop (When level control is used)

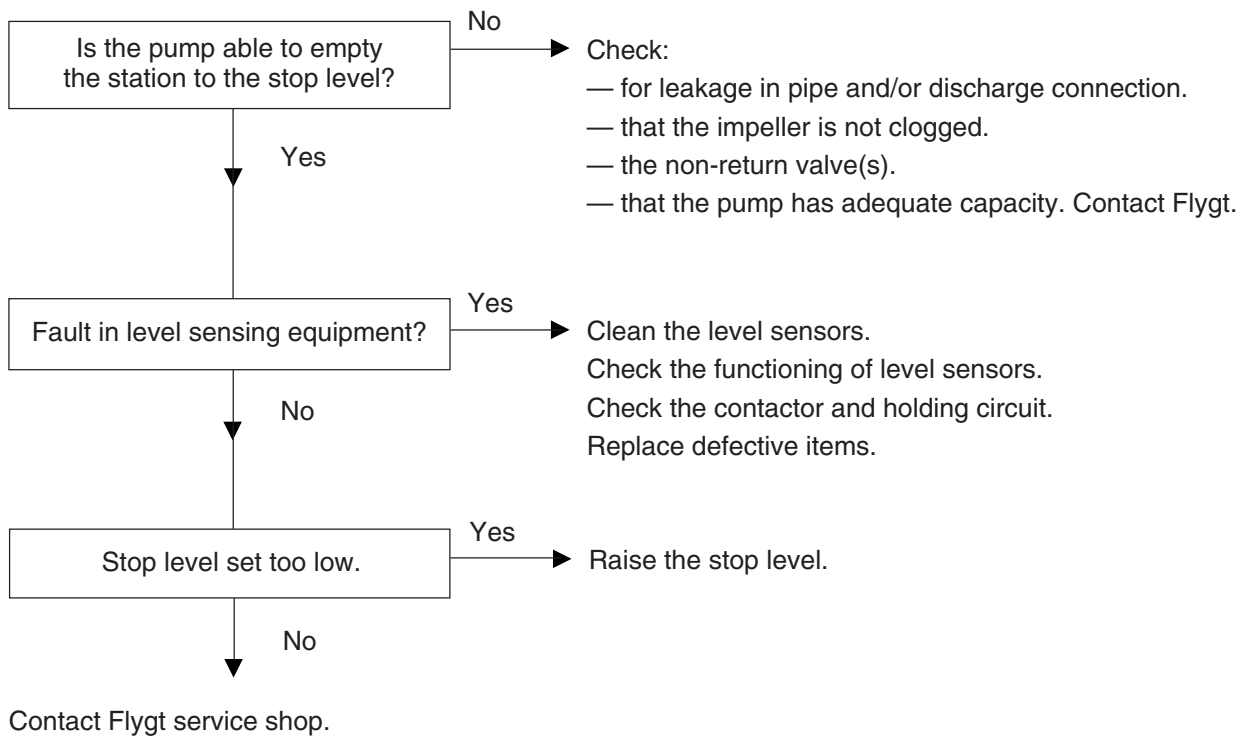

4. The pump starts-stops-starts in rapid sequence

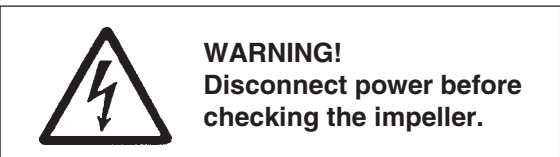
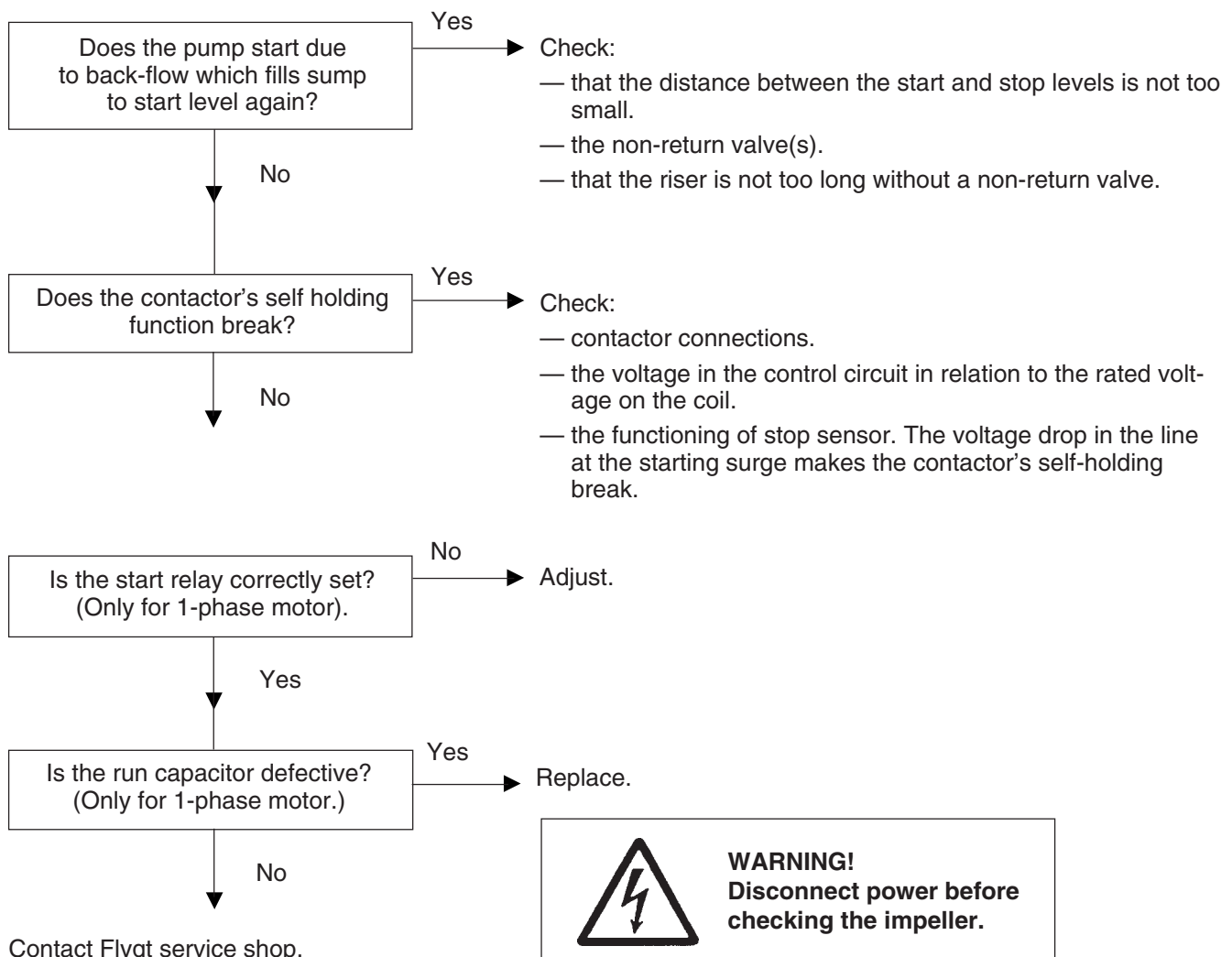

5. Pump runs but delivers too little or no water

Check:

- direction of rotation of pump, see “Before starting”.
- that valves are open and intact.
- that pipes, impeller and strainer are not clogged.
- that the impeller rotates easily.
- that the suction lift has not been altered.
- for wear on impeller, pump casing, suction bottom, diffuser disc, diffuser.

See also under “Inspection”.

Do not override the motor protection repeatedly if it has tripped.

ACCESSORIES AND TOOLS

Tandem operation

The delivery head can be increased by connecting two or three pumps in tandem.

Max. permissible operating pressure is 1,0 MPa (145 psi).

The vertical distances between the pumps should be approximately equal.

See special brochure that describes the procedure for tandem connection.

The following complete connection units are available for tandem connection:

Order No.	Description
342 58 00	2" hose
342 58 01	R 2" threaded
342 58 02	NPSM 2—11½
342 58 03	3" hose
342 58 04	R 3" threaded
342 58 05	Unit for NPSM 3—8

Zinc anode set

In order to reduce corrosion on the pump, it can be fitted with zinc anodes.

Order No. 429 90 00

Level sensor

Flygt supplies level sensors suited for different liquid densities and with different cable lengths. See separate brochure.

Start and control equipment

Flygt has suitable start and control equipment for the pump. Contact Flygt for further information.

Tools

Besides ordinary standard tools, the following tools are required in order to perform the necessary care and maintenance of the pump:

Order No.	Description
500 03 00	Drainage tube
427 07 00	Push screw
84 20 48	Impeller puller
342 96 00	Sleeve

For further information on tools, see Flygt's Tool Catalogue.

SERVICE LOG

Most recent service date	Pump No.	Hours of operation	Remarks	Sign.

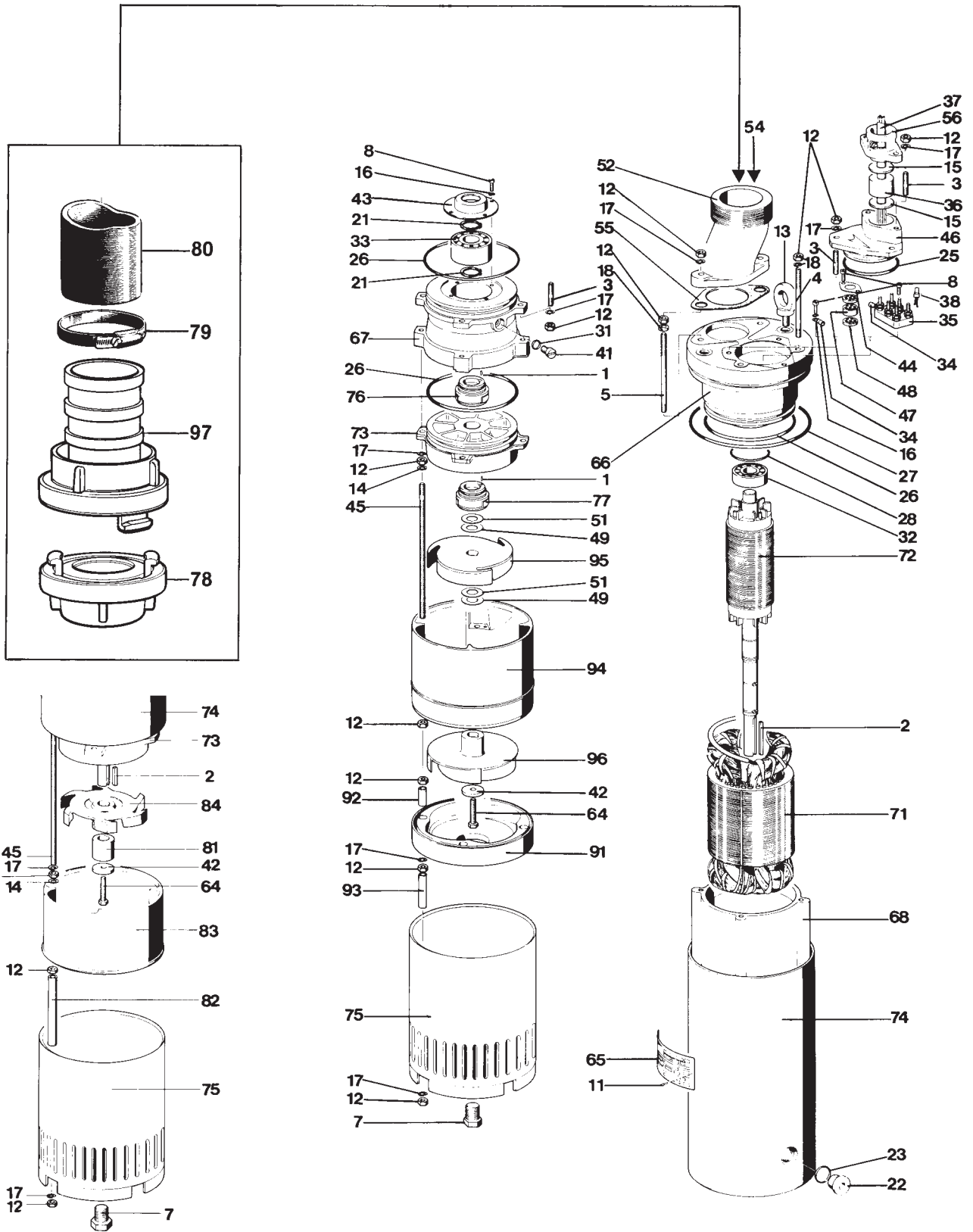



www.flygt.com